

Be the **ONE**\*

# LS TRACTOR OPERATOR'S MANUAL

MT563 • MT568 • MT573



**LS** Tractor



# CALIFORNIA

## PROPOSITION 65 WARNING



**WARNING:** Breathing diesel engine exhaust exposes you to chemicals known to the State of California to cause cancer and birth defects or other reproductive harm.

- Always start and operate the engine in a well-ventilated area.
- If in an enclosed area, vent the exhaust to the outside.
- Do not modify or tamper with the exhaust system.
- Do not idle the engine except as necessary.

For more information, go to [www.P65warnings.ca.gov/diesel](http://www.P65warnings.ca.gov/diesel)

**WASH YOUR HANDS AFTER HANDLING.**



# **FEDERAL and CALIFORNIA EMISSION CONTROL SYSTEM WARRANTY STATEMENT**

## **YOUR WARRANTY RIGHTS AND OBLIGATIONS**

The California Air Resources Board (CARB), U.S. Environmental Protection Agency (EPA), and LS Mtron Ltd. (LS Mtron) are pleased to explain the emission control system warranty on your 2021 model year engine. New engines must be designed, built and equipped to meet stringent anti-smog standards. LS Mtron must warrant the emission control system on your engine for the periods of time listed below provided there has been no abuse, neglect or improper maintenance or usage of your engine. Additional conditions and responsibilities are further outlined below. Where a warrantable condition exists, LS Mtron will repair your engine at no cost to you including diagnosis, parts and labor.

### **MANUFACTURER'S LIMITED WARRANTY COVERAGE:**

LS Mtron warrants to the original owner, and to each subsequent owner of a new diesel engine, that the emission control system of your engine:

1. Was designed, built and equipped so as to conform at the time of sale with all applicable regulations of CARB and EPA.
2. Is free from defects in material and workmanship which will cause such engine to fail to conform with applicable regulations for the following warranty period:
  - For engines rated at or above 19 kW (25 HP): five (5) years or 3,000 hours of operation, whichever occurs first.

The warranty period shall begin:

- On the date the equipment is first delivered to the first retail purchaser, or;
- If the equipment is placed in service for demonstration purposes prior to sale at retail, on the date the engine is first placed in service.

The emission control systems of your new LS Mtron engine were designed, built and tested using genuine LS Mtron parts, and the engine is certified as being in conformity with CARB and EPA emission control regulations. Accordingly, it is recommended that any replacement parts used for maintenance, repair, or replacement of emission control systems must be LS Mtron parts. Any replacement part may be used in the performance of any maintenance or repairs and will be provided without charge to the owner, although LS Mtron recommends that the owner obtain assurance that such parts are warranted by their manufacturer and LS Mtron to be equivalent to genuine LS Mtron parts. Such use shall not reduce the warranty obligations of LS Mtron, provided they are warranted to be equivalent to genuine LS Mtron parts.

Any warranted part which is not scheduled for replacement as required maintenance shall be warranted for the warranty period defined above. If any such part fails during the period of warranty coverage, and provided that there has been no abuse, neglect or improper maintenance or usage of your engine, it will be repaired or replaced under warranty. Any such part repaired or replaced under the warranty shall be warranted for the remaining warranty period.

Any warranted part which is scheduled only for regular inspection in the written instructions shall be warranted for the warranty period defined above, provided that there has been no abuse, neglect or improper maintenance or usage of your engine. A statement in the written instructions to the effect of "repair or replace as necessary" shall not reduce the period of warranty coverage. Any such part repaired or replaced under warranty shall be warranted for the remaining warranty period.

Any warranted part which is scheduled for replacement as required maintenance shall be warranted for the period of time prior to the first scheduled replacement point for that part. If the part fails prior to the first scheduled replacement, the part shall be repaired or replaced by LS Mtron under warranty, provided that there has been no abuse, neglect or improper maintenance or usage of your engine. Any such part repaired or replaced under warranty shall be warranted for the remainder of the period prior to the first scheduled replacement point for the part.

LS Mtron provides warranty services or repairs at all manufacturer distribution centers (warranty stations) that are franchised to service the subject engines. Please see the Customer Assistance section of this statement for help in locating such service centers. Repair or replacement of any warranted part under warranty shall be performed at no charge to the owner at a warranty station.

The owner will not be charged for diagnostic labor that leads to the determination that a warranted part is in fact defective, provided that such diagnostic work is performed at a warranty station.

LS Mtron is liable for damages to other engine components proximately caused by a failure under warranty of any warranted part.

LS Mtron is required by California regulations to maintain a supply of warranted parts sufficient to meet the expected demand for such parts during the warranty period for the engines covered by this warranty.

#### OWNER'S WARRANTY RESPONSIBILITIES:

This engine is designed to operate on ultra low sulfur diesel fuel only. Use of any other fuel may result in this engine no longer operating in compliance with CARB or EPA's emissions requirements.

The purchaser is responsible for initiating the warranty process. You must present the engine to a LS Mtron dealer as soon as a problem exists. The warranty repairs should be completed by the dealer as expeditiously as possible.

Use of any add-on or modified parts that are not exempted from anti-tampering laws by CARB or EPA may reduce or eliminate your warranty coverage. The use of any non-exempted add-on or modified parts shall be grounds for disallowing a warranty claim. LS Mtron is not liable for failures of warranted parts caused by the use of a non-exempted add-on or modified part.

The emissions control parts covered by this Limited Emission Control System Warranty are listed under "What is covered by the Limited Emission Control System Warranty." You are

responsible for the performance of all scheduled maintenance or repairs on your new LS Mtron engine. LS Mtron may deny a warranty claim if failure to perform maintenance results in the failure of a warranted part. Receipts covering the performance of regular maintenance should be retained in the event of questions arise concerning maintenance. The receipts should be transferred to each subsequent owner of the equipment with the emission warranted engines.

**Customer Assistance**

In the event that you do not receive the warranty service to which you believe you are entitled under the Limited Emission Control Systems Warranty, you should contact LS Mtron at the address below for assistance. If you need additional assistance or information concerning the Limited Emission Control System Warranty, contact:

- |   |  |
|---|--|
| <p>1. LS Mtron Ltd.<br/>886, Gwahak-Ro, Bongdong-Eup<br/>Wanju-gun, Jeollabuk-Do, Korea<br/>Phone: 82-63-279-5824<br/>Fax: 82-63-279-5933</p> | <p>2. LS Tractor USA LLC<br/>Ricky Mark<br/>Service Department<br/>6900 Corporation Parkway<br/>Battleboro, NC 27809<br/>Phone: 1-252-984-0700<br/>Fax: 1-252-984-0701</p> |
| <p>3. Big B Sales, Inc.<br/>Travis Bowlin<br/>674 Hwy 8,<br/>Sicily Island, LA 71368<br/>Phone: 1-318-389-5349<br/>Fax: 1-318-389-5181</p>    | <p>4. Lane Tractor Sales<br/>Michael Lane<br/>7980 Hwy 99 East;<br/>Los Molinos, CA 96055<br/>Phone: 1-530-384-1016<br/>Fax: 1-530-384-0305</p>                            |

**What is not covered by the Limited Emission Control System Warranty**

This warranty does not cover:

1. Malfunctions in any part caused by any of the following: misuse, abuse, improper adjustments, modifications, alteration, tampering, disconnection, improper or inadequate maintenance, or use of fuels not recommended for the engine as described in the Maintenance Manual.
2. Damage resulting from accident, acts of nature or other events beyond the control of LS Mtron.
3. The replacement of expendable maintenance items such as exhaust system, filters, hoses, belts, oil, thermostat, and coolant made in connection with scheduled maintenance services once these parts have been replaced.
4. Replacement items which are not genuine LS Mtron parts or not authorized by LS Mtron.
5. Loss of time, inconvenience, loss of use of equipment, engine or commercial loss.



## **What is covered by the Limited Emission Control System Warranty**

The following is a list of systems and parts that are considered a part of the Emission Control System and are covered by the Limited Emission Control System Warranty for engines which were built to conform to CARB and EPA regulations:

**IMPORTANT!** This may not include expendable maintenance items such as nozzle assemblies and rubber flanges. Emission related parts requiring scheduled maintenance are warranted until their first scheduled replacement point only.

This Limited Emission Control System Warranty applies to the following emission control parts:

- (1) Fuel System
  - (A) Fuel injection pump.
  - (B) Fuel Injectors.
  
- (2) Air Induction System
  - (A) Intake manifold.
  - (B) Turbocharger
  - (C) Air Control Valve
  - (D) Exhaust Manifold
  
- (3) Exhaust Gas Recirculation (EGR) System
  - (A) EGR valve body
  
- (4) Aftertreatment Devices
  - (A) DOC
  - (B) DPF
  
- (5) Positive Crankcase Ventilation (PCV) System.
  - (A) PCV Valve.
  - (B) Oil Filler Cap.
  
- (6) Miscellaneous items Used in Above Systems
  - (A) Vacuum, temperature, and time sensitive valves and switches.
  - (B) Electronic control units, sensors, solenoids, and wiring harnesses.
  - (C) Hoses, belts, connectors, assemblies, clamps, fittings, tubing, sealing gaskets or devices, and mounting hardware.
  - (D) Pulleys, belts and idlers.
  - (E) Emission Control Information Labels.
  - (F) Any other part with the primary purpose of reducing emissions or that can increase emissions during failure without significantly degrading engine performance.



# CONTENTS



## 1. General Notices for Safety

<b>1-1. Note to the owner – General information</b> . . . . .	1-1
(1) Before using the tractor . . . . .	1-3
(2) Manual scope and required training level . . . . .	1-5
(3) Metric and Imperial units abbreviations . . . . .	1-7
(4) Product Identification Number (PIN) . . . . .	1-9
(5) Operator's manual storage . . . . .	1-11
(6) Tractor orientation . . . . .	1-12
<b>1-2. Safety Precautions (Read this for safety before using)</b>	
(1) Notices before using the tractor . . . . .	1-13
(2) Notices when starting Engine . . . . .	1-17
(3) Notices while operating/using the tractor . . . . .	1-18
(4) Notices when connecting Implement . . . . .	1-21
(5) Notices when towing the tractor . . . . .	1-22
(6) Notices when transporting the tractor . . . . .	1-22
(7) Notices when servicing the tractor after work . . . . .	1-23
(8) Notices when handling Diesel Fuel . . . . .	1-24
(9) Notices when leaving the tractor . . . . .	1-25
(10) Notices relating to Toxic substances . . . . .	1-25
(11) Tractor stability . . . . .	1-26
(12) Ecology and the environment . . . . .	1-29
(13) Symbols . . . . .	1-31
(14) Safety Decals . . . . .	1-32
(15) Instructional Decals . . . . .	1-40
<b>1-3. Long-term storage</b>	
(1) Preparation for storage . . . . .	1-43
(2) Check & Maintenance during storage . . . . .	1-44
(3) Preparation for Reuse . . . . .	1-45



## 2. Instruction for Safe Operation

(1) The name of each part . . . . .	2-1
<b>2-1. Boarding and Exiting the tractor</b>	
(1) Boarding the tractor . . . . .	2-2
(2) Seat adjustment . . . . .	2-3
(3) Seat belt . . . . .	2-5
(4) Tilting steering wheel . . . . .	2-6
(5) Ventilation (Cabin only) . . . . .	2-6
(6) Exiting the tractor . . . . .	2-7

# CONTENTS

## 2-2. Safety device

- (1) Hood (Bonnet) . . . . . 2-8
- (2) Fender . . . . . 2-8
- (3) PTO Safety cover and protection cap . . . . . 2-8
- (4) Roll-Over Protective Structure (ROPS) . . . . . 2-9



## 3. Instruments and Controls

### 3-1. Instrument Panel and Front controls

- (1) Instrument panel . . . . . 3-2
- (2) Key switch . . . . . 3-10
- (3) Throttle pedal . . . . . 3-10
- (4) Clutch pedal . . . . . 3-11
- (5) Shuttle lever (Synchro-shuttle) . . . . . 3-11
- (6) Brake pedals . . . . . 3-12
- (7) Combination light switch . . . . . 3-13
- (8) Hazard warning light switch . . . . . 3-16
- (9) Grille work light switch . . . . . 3-17
- (10) DPF switch . . . . . 3-18
- (11) Beacon lamp switch (if fitted) . . . . . 3-23
- (12) 540E PTO switch (if fitted) . . . . . 3-23

### 3-2. Right-hand controls and Cabin pillar

- (1) Throttle lever . . . . . 3-24
- (2) Main gear shift lever . . . . . 3-25
- (3) Work light switch . . . . . 3-26
- (4) Window wiper&washer switch (Cabin only) . . . . . 3-27
- (5) Electrical power outlet socket (Cabin only) . . . . . 3-28
- (6) Indoor light (Cabin only) . . . . . 3-28
- (7) Audio player (Cabin only) (if fitted) . . . . . 3-28
- (8) 4WD switch . . . . . 3-29
- (9) Parking brake lever . . . . . 3-29
- (10) Differential lock switch . . . . . 3-30
- (11) PTO mode switch (optional) . . . . . 3-31
- (12) PTO switch . . . . . 3-32
- (13) Engine Speed Cruise Control (ESC) switch . . . . . 3-33

### 3-3. Left-hand controls

- (1) Range gear shift lever . . . . . 3-35
- (2) Creeper gear lever (if fitted) . . . . . 3-36
- (3) PTO gear lever . . . . . 3-36
- (4) Passenger's seat (if fitted) . . . . . 3-37

# CONTENTS

## **3-4. Power Shuttle System (PSS) (if fitted)**

- (1) Power shuttle lever (PSS) . . . . . 3-38
- (2) Clutch pedal (PSS) . . . . . 3-40
- (3) Clutch button (PSS) . . . . . 3-41
- (4) CAL/SEL switch (PSS) . . . . . 3-41
- (5) Engaging speed +/- switch (PSS) . . . . . 3-42
- (6) Error Diagnosis Code (PSS) . . . . . 3-43

## **3-5. Hydraulic system**

- (1) Safety precautions . . . . . 3-45
- (2) Steering system . . . . . 3-46
- (3) Hydraulic lift Control (MHL) . . . . . 3-47
- (4) Remote control lever and Quick coupler (optional) . . . . . 3-50
- (5) Joystick lever (optional) . . . . . 3-51
- (6) Auto lift control (MHL, if fitted) . . . . . 3-52
- (7) Hydraulic System Diagram . . . . . 3-53

## **4. Operation and Work**

### **4-1. How to handle new tractor**

- (1) Check points . . . . . 4-1
- (2) Notices in handling new tractor (Engine brake-in procedure) . . . . . 4-1

### **4-2. Engine start and stop**

- (1) Engine start . . . . . 4-2
- (2) Start in cold weather . . . . . 4-4
- (3) Engine stop . . . . . 4-4

### **4-3. How to drive and stop**

- (1) Transmission Warm-up in cold weather . . . . . 4-5
- (2) How to drive . . . . . 4-6
- (3) Changing speed . . . . . 4-8
- (4) Emergency Stop . . . . . 4-8
- (5) Stopping tractor . . . . . 4-9
- (6) Parking . . . . . 4-10
- (7) Handling Turbocharger (if fitted) . . . . . 4-10

### **4-4. Transport on public roads**

- (1) Safety rules when driving tractor on the roads . . . . . 4-11
- (2) Light operation . . . . . 4-12
- (3) 7-Pole connector (optional) . . . . . 4-13
- (4) Notices when towing the tractor . . . . . 4-14
- (5) Notices when transporting the tractor . . . . . 4-16

# CONTENTS

## 4-5. Field Operations

- (1) Rear 3-point linkage . . . . . 4-17
- (2) Power take-off (PTO) operation . . . . . 4-21
- (3) Hitch and Drawbar (optional) . . . . . 4-25
- (4) Technically maximum permissible mass . . . . . 4-26
- (5) Tires and Load capacity . . . . . 4-27
- (6) Adjusting Wheel tracks and tire replacement . . . . . 4-28
- (7) Using Front-end loader (if fitted) . . . . . 4-33
- (8) Adjusting Steering angle . . . . . 4-36
- (9) Recommended Maximum Specification of Implements . . . . . 4-37
- (10) Ballasting Weights (optional) . . . . . 4-38
- (11) Working in hazardous area . . . . . 4-41

## 4-6. Driving Speed . . . . . 4-42



## 5. Lubrication and Maintenance

### 5-1. General information . . . . . 5-1

- (1) Tightening Torque for normal assembly . . . . . 5-2
- (2) Standard torque data for hydraulics . . . . . 5-4
- (3) General specification - Diesel fuel . . . . . 5-7
- (4) Biodiesel fuel . . . . . 5-8
- (5) Refueling the tractor . . . . . 5-10
- (6) Change engine coolant to Organic Acid Technology (OAT) coolant . . . . . 5-11
- (7) Access for maintenance . . . . . 5-12

### 5-2. Maintenance chart . . . . . 5-13

### 5-3. Lubricants and Capacity . . . . . 5-15

### 5-4. First 50 hour check . . . . . 5-16

### 5-5. When the warning indicator lights

- (1) Drain water from Fuel filter . . . . . 5-17
- (2) Engine oil pressure indicator . . . . . 5-18
- (3) Battery charging indicator . . . . . 5-18

### 5-6. Check before starting (Daily check)

- (1) Engine oil . . . . . 5-19
- (2) Fuel tank . . . . . 5-20
- (3) Instrument panel & Indicators . . . . . 5-20
- (4) Turn signal lights, Lights and Horn . . . . . 5-21
- (5) Engine coolant . . . . . 5-21
- (6) Air cleaner (Dry type) . . . . . 5-22
- (7) Cleaning of Radiator and Radiator screen . . . . . 5-23
- (8) Tire air pressure damage . . . . . 5-23

# CONTENTS

(9) Tightening state of bolt and nut of each part . . . . .	5-24
(10) Adjustment of Clutch pedal play . . . . .	5-25
(11) Adjustment of brake pedal play . . . . .	5-26
<b>5-7. Every 50 hour check</b>	
(1) Lubricating grease nipple . . . . .	5-27
(2) Cleaning Radiator and Radiator screen . . . . .	5-27
(3) Checking Transmission oil . . . . .	5-28
(4) Checking Front axle oil . . . . .	5-28
(5) Battery check . . . . .	5-29
(6) Air cleaner (Dry type) . . . . .	5-29
(7) Hydraulic hoses and Leakage . . . . .	5-29
(8) Cleaning Cabin air filters . . . . .	5-29
<b>5-8. Every 100 hour check</b>	
(1) Checking and adding Engine oil . . . . .	5-30
<b>5-9. Every 300 hour check</b>	
(1) Replacing Engine oil and Filter . . . . .	5-31
(2) Replacing Hydraulic oil filter . . . . .	5-32
(3) Replacing Power shuttle oil filter (if fitted) . . . . .	5-32
(4) Checking Brake oil . . . . .	5-33
(5) Tension adjustment of Fan belt . . . . .	5-34
(6) Toe-in . . . . .	5-34
(7) In-line pressure filter (if fitted) . . . . .	5-34
(8) Cleaning fuel tank . . . . .	5-35
<b>5-10. Every 500 hour check</b>	
(1) Changing Front axle oil . . . . .	5-36
(2) Changing Transmission oil . . . . .	5-37
(3) Replacing Fuel filter cartridge . . . . .	5-38
(4) Replacing Cabin air filters . . . . .	5-39
<b>5-11. Every 1000hr or 1-year check</b>	
(1) Replacing Air cleaner element (Dry type) . . . . .	5-40
(2) Adjusting Engine valve clearance . . . . .	5-41
(3) Checking Nozzle injection pressure . . . . .	5-41
<b>5-12. Every 1500hr or 2-year check</b>	
(1) Replacement of Engine coolant . . . . .	5-42
(2) Cleaning Emission related parts . . . . .	5-45
<b>5-13. Every 3000hr check</b>	
(1) Cleaning Emission related parts . . . . .	5-46

# CONTENTS

## **5-14. General maintenance (When required)**

(1) Air-bleeding from Fuel system . . . . .	5-47
(2) Air-bleeding from brake lines . . . . .	5-50
(3) Air-bleeding from clutch line (Synchro-shuttle models only) . . . . .	5-50
(4) Fuse & Main fuse . . . . .	5-51
(5) Battery handling and Notices . . . . .	5-54
(6) Alternator and drive belt - Check . . . . .	5-58
(7) Turn signal light bulb - Replace . . . . .	5-59
(8) Headlight bulb - Replace . . . . .	5-60
(9) Touch-up paint color . . . . .	5-61
<b>5-15. Troubleshooting . . . . .</b>	<b>5-62</b>



## **6. Air Conditioning System (Cabin type)**

<b>6-1. The name of each part of cooling and heating system . . . . .</b>	<b>6-1</b>
<b>6-2. How to use air conditioner and heater</b>	
(1) How to operate air conditioner and heater . . . . .	6-2
(2) Air direction control . . . . .	6-2
<b>6-3. Every 6 month check</b>	
(1) Checking refrigerant amount . . . . .	6-3
(2) Cleaning condenser and Radiator screen . . . . .	6-3
(3) Checking leakage . . . . .	6-3
(4) Belt tension adjustment . . . . .	6-4
(5) Cleaning and replacing cabin air filters . . . . .	6-4
<b>6-4. Every year check</b>	
(1) Compressor check . . . . .	6-5
(2) Control switch check . . . . .	6-5
<b>6-5. Using Cut-off valve (if necessary) . . . . .</b>	<b>6-6</b>
<b>6-6. Troubleshooting . . . . .</b>	<b>6-7</b>
<b>6-7. System diagram . . . . .</b>	<b>6-9</b>



## **7. Dimension Specification . . . . . 7-1**



# 1. General Notices for Safety

## 1-1. Note to the owner – General information

### Operator's manual

Please have all operators read this manual carefully and keep this manual available for ready reference. Read this manual to make sure that you have a complete understanding of how to operate this tractor safely, correctly, and for the most effective performance of the tractor.

**NOTE:** This operator's manual may be available in other languages; see your authorized local dealer for ordering.

This manual contains important information concerning the adjustment and maintenance of your new equipment.

**NOTE:** Some images of the tractor in this manual may differ slightly in some detail. Any variations will be similar enough for you to understand the information or instructions.

Throughout this operator's manual, references to the right-hand and left-hand sides of the tractor are determined by facing the forward operating direction of travel.



This is the safety alert symbol. The safety alert symbol alerts you to potential personal injury hazards. Obey all safety messages that follow this symbol to avoid possible death or injury.

	<p>► <b>Illustrations in this manual may show protective shielding open or removed to better illustrate a particular feature or adjustment. Replace all shields before operating the tractor. Failure to comply could result in death or serious injury.</b></p>
---	--

### ◆ Safety Mark Description

- In the places where the cautions in usage are required, the marks such as “**DANGER**”, “**WARNING**”, “**CAUTION**” are found.
- You should comply with the description marked on the decals attached on the product or the contents marked with safety mark in this Operator's Manual.



**Danger** - This indicates a fatal dangerous situation that may cause a serious injury or death if not avoided.



**Warning** - This indicates a potential dangerous situation that may cause a serious injury or death if not avoided.



**Caution** - This indicates a potential dangerous situation that may cause a light injury or damage to the properties if not avoided.

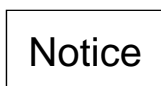

**Notice** - This indicates the instructions for right use for the safety of persons or products.

## **Your authorized local dealer and service**

Your authorized local dealer has performed a pre-delivery setup, inspection, and testing to make sure that your tractor operates at its best performance level.

Your authorized local dealer will instruct you in the general operation of your new equipment. Your dealer's staff of factory-trained service technicians will be glad to answer any questions that may arise regarding the operation of your tractor.

Your authorized local dealer carries a complete line of genuine service parts. These parts are manufactured and carefully inspected to ensure high quality and accurate fitting of any necessary replacement parts. Be prepared to give your dealer the model and product identification number of your new equipment when ordering parts. Locate these numbers now and record them below. Refer to the 'General Information' section of this manual for the location of the model and product identification numbers of your tractor.

***ATTENTION:*** *The engine and fuel system on your tractor is designed and built to government emission standards. Tampering by dealer, customers, operators, and end users is strictly prohibited by law. Failure to comply could result in government fines, rework charges, invalid warranty, legal action, and possible confiscation of the tractor until rework to original condition is completed. Engine service and/or repairs must be done by a certified technician only!*

## **Improvements**

We are continually striving to improve its products. We reserve the right to make improvements or changes when improvements or changes become practical and possible to do so, without incurring any obligation to make changes or additions to the equipment sold previously.

## (1) Before using the tractor



※ **Must read and understand this operator's manual carefully and always refer to information and prescriptions outlined in this manual to prevent all potential health and safety risks.**

### ◆ General information for intended use

- Your tractor is designed and manufactured to pull, to carry, to supply the power a variety of mounted or towed equipment **for agriculture**. Do not use the product for other purposes than intended by the manufacturer and outlined in this manual. Do not use this tractor for light/heavy forestry applications.
- Do not use the product beyond its **limits of terrain gradient** and stability than outlined in this manual. Using the tractor beyond these limits may cause a overturning accident.
- Do not use the tractor on higher speeds than allowed by the load of the tractor and road condition. Always choose **a suitable driving speed** to maintain the stability of the tractor.
- Do not use the tractor **near or on soft verges** of canals and brooks or banks and verges that are undermined by rodents. The tractor may sink sideways and roll-over.
- Do not use the tractor on brittle bridge heads and poor bridge floors. These constructions may collapse and cause overturning of the tractor. **Always check out the condition and carrying capacity of bridges and ramps** prior to engage.
- **Do not use the tractor without wearing the seat belt and Roll-Over Protective Structure (ROPS)** during operations where roll-over or tip-over hazards exist. The ROPS will only be fully effective when the driver remains attached to his/her seat.
- Do not use equipment mounted on the tractor which is not **correctly matching and firmly fixed**. Such equipment may increase the risk for roll-over and hit the tractor when coming loose.
- Do not use the tractor in combination with equipment arbitrary, without **having consulted the specific operator's manual provided with the equipment**. This manual alone cannot provide you with all the information about safety operation of the combination.
- Do not use the tractor beyond its **limits of dynamic stability**. High speed, abrupt maneuvers, and fast and short cornering will increase the risk of roll-over.
- Do not use the tractor for **overloaded pulling work**, in cases where you don't know if the load will yield, for instance when pulling stumps. The tractor may flip over when the stump is not yielding.
- Be extremely cautious when working with the tractor **on forage silos without lateral concrete walls**. A wide track setting may improve the lateral stability of the tractor.
- Be cautious that the **center of gravity of the tractor may increase** when the front-end loader is loaded or the three-point linkage are raised. In these conditions, the tractor may roll-over earlier than expected.
- **Do not step down from the tractor without shutting down the PTO, shifting the transmission to neutral and applying the parking brake.**

- **Never remove or modify or change** the driver's protection device or safety device arbitrary.  
*Any unauthorized modifications made to this tractor can have serious consequences. Consult an authorized dealer on changes, additions, or modifications that may be required for this tractor. Do not make any unauthorized modifications.*
- You must take the necessary precautions to always be **aware of the possible presence of bystanders**, certainly when maneuvering in confined areas. Keep people away from the tractor during work. Pay the necessary attention while operating next to public roads or footpaths. Thrown objects can get projected outside the field and hit unprotected people like bikers or pedestrians. Wait until it is clear of bystanders.
- Do not violate the **local traffic rules** related to public roads and highways.
- **Do not allow riders** on the tractor; do not allow people standing on the access way or step to the cab when the tractor is moving. Your view to the left will be obstructed and a rider risks to fall from the tractor during unforeseen or abrupt movements.
- **This tractor has only one operator station** and is a one man operated vehicle. Other people on or around the tractor during normal operation are not allowed.
- Always stay clear from implements operating area and especially **do not stand between tractor and trailed vehicle either three-point linkage when operating lift controls**; ensure no bystanders are near these operating areas.
- This tractor may be equipped with a number of sensors to control safety functions. **Do not attempt to bypass any function** on the tractor. You will be exposed to serious hazards, and moreover, the behavior of the tractor may become unpredictable.
- The manufacturer will not be responsible for the damage or safety problems caused by maintenance or repair with non-genuine parts. It must be requested to **use the genuine parts**.
- When cleaning the tractor by using high pressurized water, **do not inject water directly to the electronic parts, wiring, air intake pipe, hot engine or muffler** inside the bonnet.
- Maintenance and repair of the tractor is performed by **skilled technical experts with the proper tools** authorized by the manufacturer.
- Pay attention to **overhead power lines and hanging obstacles**. High voltage lines may require significant clearance for safety.
- Do not operate the tractor during an **electrical storm. (Lightening strikes)**
- For damage or accidents caused by misuse or operation in violation of these rules, the manufacturer and its distributors **will not have any responsibility and warranty**.
- **Keep this operator's manual** for future reference at hand (on the tractor).

## **(2) Manual scope and required training level**

### **Introduction to this manual**

This manual gives information about the use of your tractor as intended and under the conditions foreseen by manufacturer during normal operation, routine service, and maintenance.

This manual does not contain all the information that relates to periodic service, conversions, and repairs that only trained service personnel can perform. Some of these activities may require appropriate facilities, technical skills, and/or tools that manufacturer does not supply with the tractor.

The manual contains the chapters as shown on the Contents pages.

### **Normal operation**

Normal operation consists of the use of this tractor for the purpose manufacturer intends by an operator that:

- Is familiar with the tractor and any mounted equipment or towed equipment.
- Complies with the information on operation and safe practices as specified by manufacturer in this manual and by the signs on the tractor.

Normal operation includes:

- Preparation and storage of the tractor.
- Addition and removal of ballast.
- Connection and disconnection of mounted equipment and/or towed equipment.
- Adjustment and configuration of the tractor and equipment for the specific conditions of the job site, field, and/or crop.
- Movement of components into and out of working positions.

### **Routine service and maintenance**

Routine service and maintenance consists of the daily activities necessary to maintain the proper tractor function. The operator must:

- Be familiar with the tractor characteristics.
- Comply with the information on routine service and safe practices as specified by manufacturer in this manual and by the signs on the tractor.

Routine service can include:

- Fueling
- Cleaning
- Washing
- Topping up fluid levels
- Greasing
- Replacing consumable items such as light bulbs

### **Periodic service, conversions, and repairs**

Periodic service consists of activities that are necessary to maintain the expected life of your tractor. These activities have defined intervals.

Trained service personnel familiar with the tractor characteristics must perform these activities at the defined intervals. Trained service personnel must comply with the information on periodic service and safe practices as partly specified by manufacturer in this manual and/or other company literature.

Periodic service includes:

- Oil change service for the engine, hydraulic circuits, or transmission.
- Periodic exchange of other substances or components as required.

Conversion activities rebuild your tractor in a configuration that is appropriate for a specific job site, crop, and/or soil conditions (e.g., installation of dual wheels). Conversion activities must be done:

- By trained service personnel familiar with the tractor characteristics.
- By trained service personnel that comply with the information on conversion as partly specified by manufacturer in this manual, assembly instructions, and/or other company literature.

Repair activities restore proper function to your tractor after a failure or degradation of performance. Dismantling activities occur during the scrapping and/or dismantling of the tractor.

Trained service personnel familiar with the tractor characteristics must perform these activities. Trained service personnel must comply with the information for repair as specified by manufacturer in the service manual.

## **Before you operate**

Read this manual before you start the engine or operate this tractor. Contact your authorized local dealer if:

- You do not understand any information in this manual.
- You need more information.
- You need assistance.

All persons training to operate, or who will operate this tractor should be old enough to possess a valid local vehicle operating permit (or meet other applicable local age requirements). These persons must demonstrate the ability to operate and service the tractor in a correct and safe manner.

### (3) Metric and Imperial units abbreviations

	Metric unit		Imperial unit	
	Name	Symbol	Name	Symbol
Area	Square meter	m <sup>2</sup>	Square foot	ft <sup>2</sup>
	Square centimeter	cm <sup>2</sup>	Square inch	in <sup>2</sup>
	Square millimeter	mm <sup>2</sup>	Square inch	in <sup>2</sup>
Electricity	ampere	A	ampere	A
	volt	V	volt	V
Force	kilonewton	kN	pound	lb
	newton	N	pound	lb
Frequency	megahertz	MHz	megahertz	MHz
	Kilohertz	kHz	Kilohertz	kHz
	hertz	Hz	hertz	Hz
Rotational frequency	Revolution per minute	rpm	Revolution per minute	rpm
Length	kilometer	Km	mile	mi
	meter	m	foot	ft
	centimeter	cm	inch	in
	millimeter	mm	inch	in
Mass	kilogram	kg	pound	lb
	gram	g	ounce	oz
Power	kilowatt	kW	horsepower	Hp or ps
	watt	W	Btu per hour Btu per minute	Btu/hr Btu/min
Pressure or stress (Force per area)	kilopascal	kPa	Pound per square inch	psi
	megapascal	MPa	Pound per square inch	psi
	bar	bar	Pound per square inch	psi
	Kilogram per square centimeter	Kg/cm <sup>2</sup>	Pound per square inch	psi
Temperature	Degrees Celsius	°C	Degrees Fahrenheit	°F

	Metric unit		Imperial unit	
	Name	Symbol	Name	Symbol
Time	hour	hr	hour	hr
	minute	min	minute	min
	second	s	second	s
Torque	Newton meter	N.m	Pound foot	lb.ft
	Kilogram meter	Kg.m	Pound foot	lb.ft
Velocity	kilometer per hour	km/h	mile per hour	mph
	meter per second	m/s	foot per second	ft/s
Volume	Cubic meter	m <sup>3</sup>	Cubic yard	yd <sup>3</sup>
	liter	L	Cubic inch	in <sup>3</sup>
	liter	L	US gallon	US gal
	cc	cc	Cubic inch	in <sup>3</sup>
Volume per time (flow rate)	Liter per minute	L/min	US gallon per minute	US gal/min
Sound pressure level	decibel	dB	decibel	dB

## Glossary

Acronym	Definition
MEC	Synchro shuttle transmission
HST	Hydrostatic transmission
PSS	Power shuttle system
PST	Power shift transmission
MHL	Mechanical Hydraulic Lift
EHL	Electro-Hydraulic Lift
DEF	Diesel Exhaust Fluid
DPF	Diesel Particle Filter
ISO	International Organization for Standardization
MSDS	Material Safety Data Sheet
NOx	Nitrogen Oxide
PPE	Personal Protective Equipment
SCR	Selective Catalytic Reduction
<	Less than
>	Greater than



## (4) Product Identification Number (PIN)

The tractor and major components are identified with Product Identification Number (PIN) plates. You should supply the PIN plate data to your authorized local dealer when requesting parts or service, and also to identify the tractor in case of theft.

### ① Product Identification Number (PIN) plate

- The tractor PIN Plate① is located on the left-hand side of the engine frame.
- This may vary depending on the market.

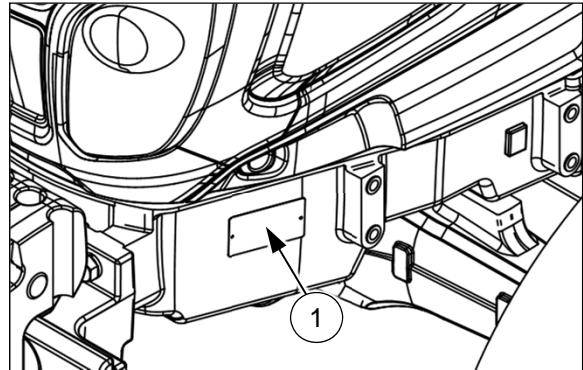

<b>LS</b> <b>LS Mtron Ltd.</b>	
MODEL	
CHASSIS NO.	
ENGINE NO.	
T/M NO.	
886, Gwahak-ro, Wanju-gun, Jeollabuk-do, 55322, KOREA / Tel. (+82-63) 279-5114	
40341981/01	

### ② Engine Product Identification Number (PIN) plate

- The engine PIN plate② is located on the left-hand side of the engine oil sump.

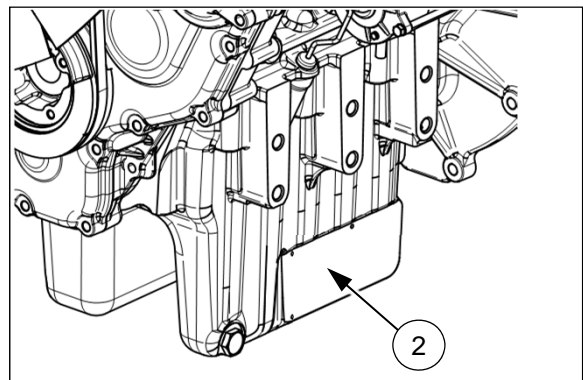

### ③ Roll Over Protective Structure (ROPS) Product Identification Number (PIN)

- The Roll Over Protective Structure (ROPS) PIN plate③ is located on the left-hand side of the cabin rear steel plate for cabin models.
- This may vary depending on the market.

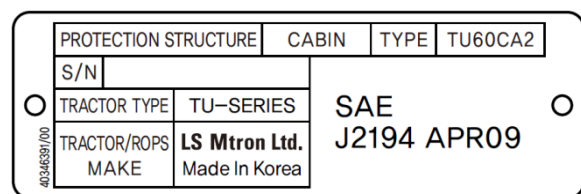
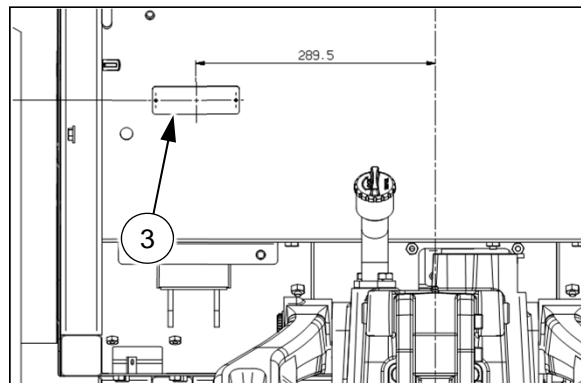

### ④ TM number and Running hours

- In case of requesting service or parts from your dealer, the dealer may ask you to provide the TM number④ and/or running hours⑤ displayed on the instrument panel.

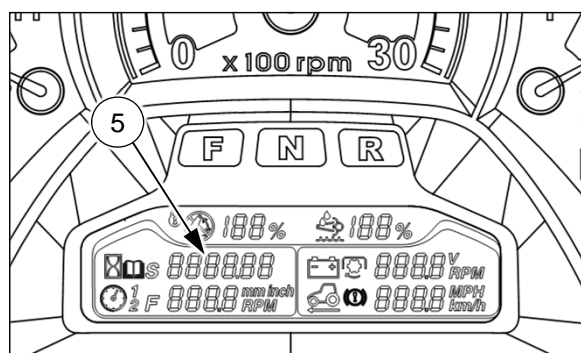
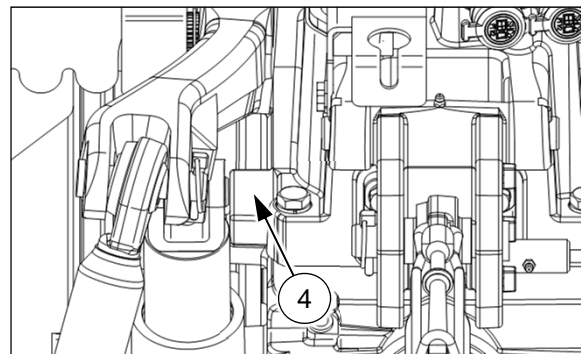

## (5) Operator's manual storage

- The operator's manual must be stored in a secure place prior to operation and it must be kept available for use by all operators.

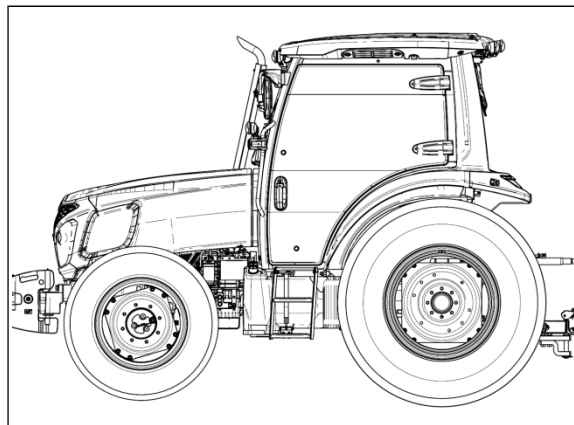

- You can use the manual storage box installed on the rear side of the driver's seat. It may vary depending on the driver's seat.
- To open the box, pull the upper side of the cover ① rearward.

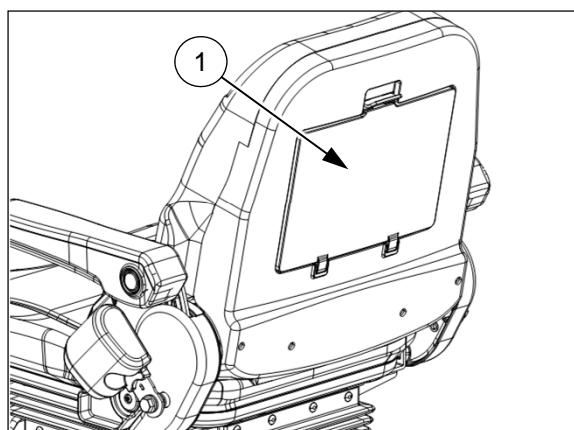

**(6) Tractor orientation**

***NOTE:** On this equipment, left-hand and right-hand are determined by standing behind the unit, looking in the direction of travel.*

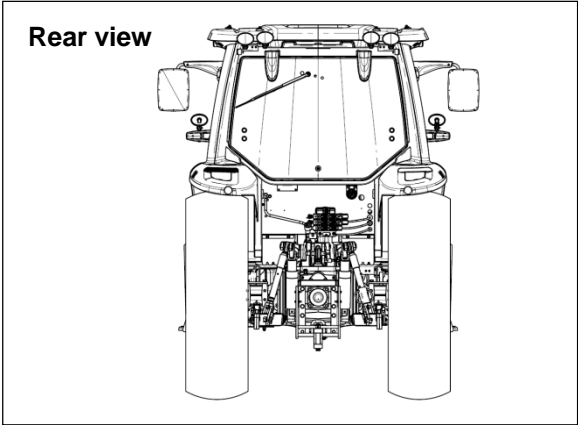
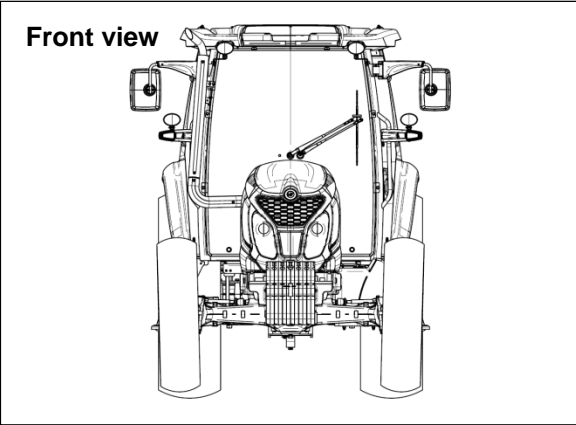
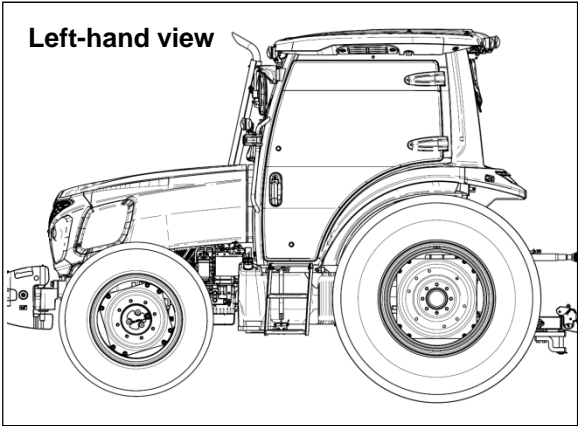

*When reading this Operator's Manual, refer to the right figure for the discrimination of the directions.*

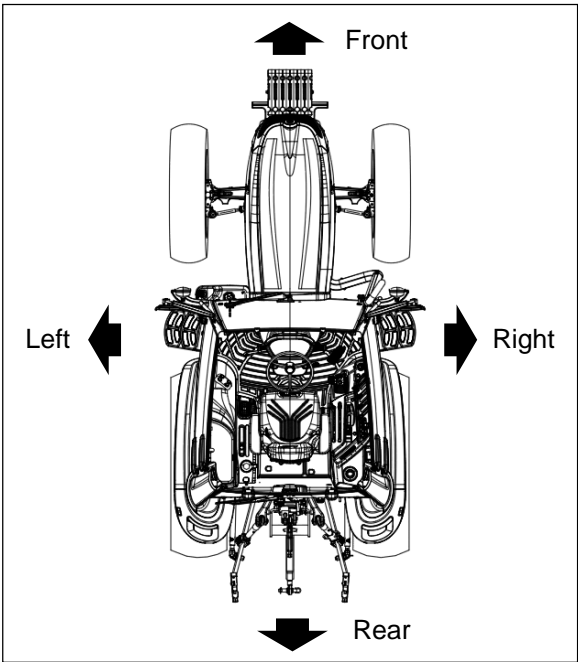

## 1-2. Safety Precautions - read this for safety before using.

### (1) Notices before using the tractor

- **For Safety operation** : Before using this tractor, read carefully and understand this operator's manual and operator's manual of the mounted or trailed machinery on this tractor, and strictly follow the instructions outlined in the operator's manuals.

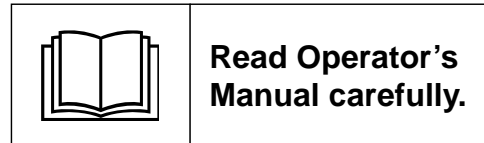

**Especially, special cares must be taken for using the tractor in the places where the safety signs such as Danger, Warning, Caution etc. are marked. (See page 1-1)**

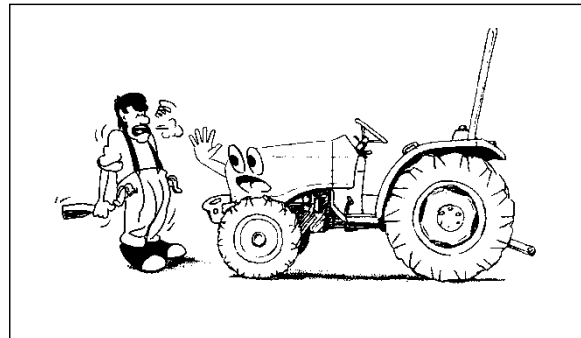

- **Safety Decals** : For right use and personal safety of the operator, the safety decals are attached to the parts related with safety operation. Before using the tractor, comply with the safety instructions. (For further information, refer to the chapter 1-2-(14). "Safety Decals" in this manual.)

- **Operator's condition** : The persons such as patients, drunks, people on drugs, etc. are never allowed to operate this tractor. Only educated operators can use the tractor after learning the usage of controls for moving, stopping, turning and other operating.

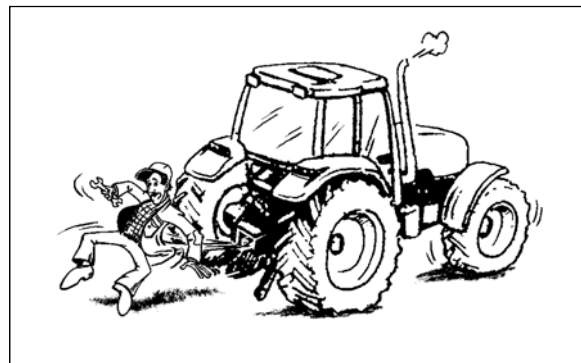

- **Suitable Clothes & Protect Entanglement** : When checking or operating the tractor, wear tight fitting clothes and safety equipment instead of loose or long clothes. Also, slippers, high heel shoes are not suitable for operation. Wear the low shoes or work shoes or boots.



	▶ Do not approach the rotating shaft such as PTO shaft or cooling fan, especially, with loose clothing and long clothes. The entanglement in rotating shaft can cause serious injury or death.
	▶ Stop the engine and be sure PTO shaft is stopped before getting near it.

- **Keep Riders off** : Riders on the tractor or implements obstruct the operator's view and can be thrown off the tractor. It can cause a serious injury or death. Riders should not be carried on the tractor at any time.

	▶ Additional seat (where fitted) is used for driver training or instruction. Do not permit anyone to ride on the tractor.
---	---

- **Protect Children** : Pay special attention to children (or a child) while using the tractor or during storage.
  - Make sure children keep a safe distance from the tractor and all implements before using the tractor. Be alert to the presence of children.
  - Do not let children or an untrained person operate the tractor.
  - Do not allow children to approach the tractor while the engine is running.
  - When parking the tractor, remove the ignition key and lower implements to the ground for children's safety.

 Warning	► As children are very curious, they may do unexpected movements or actions. Special care must be taken when operating tractor or equipment.
---	--

- **Periodical Check** : “Lubrication and Maintenance” must be performed periodically. If necessary, do it immediately and if not, it may cause a failure, reduction of product life or physical injury.

*\* Periodic Lubrication and Maintenance*

*Fuel, Oil, Filter, Air cleaner, Battery, Belt, Cable, Grease, Pedals such as clutch(Mechanical models only) and brake pedal, Tire air pressure, Wheel bolts, Toe-in, Electrical wirings, other items related to safety.*

- **Genuine Parts** : When replacing parts, you must use “Genuine Parts” of the tractor. Contact your authorized local dealer. If not, it may cause a failure, reduction of product life or serious injury.
- **Restrict Maintenance** : If repairing or changing some components or settings arbitrary, the performance of the tractor can NOT be guaranteed, and may void the warranty. And also, maintenance of the heavy weighted parts without special tools may cause serious injury. These works have to be treated by well-educated and skilled service experts. If required to check or repair the tractor due to such a trouble, or having any question about your tractor, contact your authorized local dealer.

*\* The items that are not allowed to be modified or removed arbitrarily by user are as below :*

- *Protection structures such as PTO cover, Guards, Safety frame(Roll-bar), Cab, etc.*
- *Engine components, Fuel injection control and setting, etc.*
- *Automatic control equipment, Lamps, Transmission, Hydraulic valve and pressure settings.*
- *Other parts that detail and where complicated adjustments are needed.*

- **Lamps** : Do not modify the lamps or change the bulb capacity arbitrarily.

 Warning	► Modified lamps or change bulb capacity may cause a traffic accident by disturbing approaching driver's views. ► If the lamp is blown out, replace it immediately with a genuine part. In case of driving at night, it may cause a traffic accident.
---	--

- **Protective Structures** : For the operator's safety, various protective structures, i.e. Bonnet (Hood), Fan cover, PTO safety cover, PTO shaft protection cap, Roll-bar or another Roll-over Protective Structure, etc. are attached on the tractor. If these structures are modified or removed by user arbitrarily, it may cause serious accident. Such behaviors are prohibited strictly.

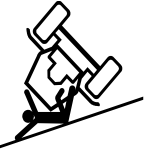
 <b>Warning</b>	<ul style="list-style-type: none"> <li>▶ The Protective Structure and interconnecting components are a certified system. Any damage, fire, corrosion or modification will weaken the structure and reduce your protection. If this occurs, the Protective Structure <b>MUST</b> be replaced with a new one. Contact your authorized local dealer for Protective Structure inspection and replacement.</li> <li>▶ In case of an accident, fire, tip or roll-over, the following <b>MUST</b> be performed by a qualified technician before operating the tractor again. <ul style="list-style-type: none"> <li>- The Protective Structure <b>MUST</b> be replaced.</li> <li>- The mounting or suspension for the Protective Structure , operator seat and suspension, seat belt and mounting components and wiring within the operator's protective system <b>MUST</b> be carefully inspected for damage.</li> <li>- All damaged parts <b>MUST</b> be replaced.</li> </ul> </li> <li>▶ <b>DO NOT attach any device to the Protective Structure for pulling purposes.</b></li> <li>▶ <b>DO NOT weld, drill holes, attempt to straighten or repair the protective structure. The modification can reduce the structural integrity of the structure which can cause death or serious injury in the event of fire, tip, roll over, collision or accident and void the warranty.</b></li> </ul>
	

- **Level of protection of the FOPS (Falling Objects Protective Structure) :**
  - **For cabin model**, it provides protection against falling objects **according to OECD code 10 standard**. The energy level of drop test is 1365 J. But it does not mean that the cabin provide full protection against all the falling objects in the work field.
  - **For roll-bar model**, it does **NOT** offer any protection against falling objects. It is recommended to use a certified FOPS structure when working with front-end loaders.
- **Level of protection against hazardous substances :**
  - **For cabin model** of this tractor, it provides protection against hazardous substances **according to EN15695-1:2009 (Category 2)**. But it can provide only dust protection level by pressurizing air in the cabin with air filters. Do not use the tractor with crop sprayers in chemical hazardous area.
  - **For roll-bar model**, it does NOT provide any protection against hazardous substances. Do not use the tractor with crop sprayers in hazardous area.
- When using an agricultural tractor with crop sprayers, the following hazards exist:
  - Risks due to spraying hazardous substances with a tractor (fitted with a cab or not).
  - Risks related to entering or exiting the cab(if fitted) during the application of hazardous substances.
  - Risks related to the possible contamination of the operating environment.
  - Risks related to cleaning the cab and maintaining the air filters (if fitted).

For protection against hazardous dust, aerosols, and vapors, see the instructions provided by the chemical agent supplier, the sprayer manufacturer, and the basic rules contained in this manual. Always use the Personal Protective Equipment (PPE) and any other special devices as instructed by the chemical supplier's instructions during spraying operations.

- **Level of protection of the OPS (Operators Protection Structure) :** This tractor does **NOT** provide protection against
  - falling objects, such as branches, logs or tree limbs, low hanging wires in the forest, orchard or construction area.
  - toppling trees, primarily in case a rear-mounted tree grab-crane is mounted at the rear of the tractor.
  - penetrating objects in the operator's enclosure, primarily in case a winch is mounted at the rear of the tractor.
  - steep slope or rough terrain working conditions.
  - potential risks by using any optional equipment that might be available to deal with those hazards.Your tractor is NOT EQUIPPED FOR FORESTRY APPLICATIONS. **NEVER enter or operate these hazardous area without certified Operator Protective Structure installed.**



## (2) Notices when starting Engine

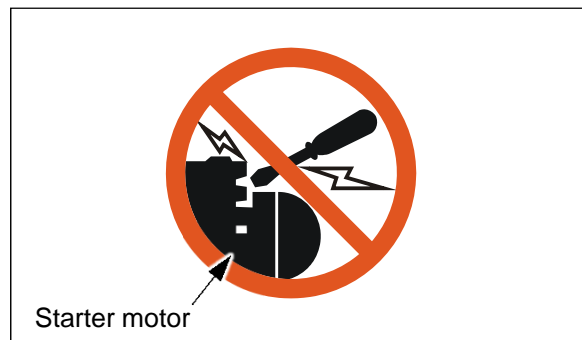
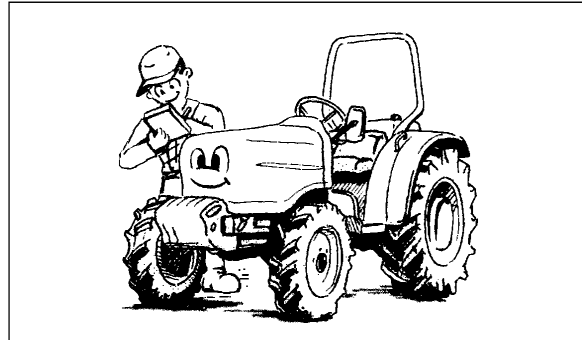

- Check each part with reference of “5. Lubrication and Maintenance” in this manual. If necessary, repair or replace it immediately. **Especially, check if safety protection structures or covers are attached originally and the bolts and nuts are tightened well.**
- Before starting, **check again if there are other workers or children around the tractor and implements and keep a safe distance.**
- Start engine and operate the tractor **after sitting on the driver’s seat** with a securely fastened seat belt.
- Place the shuttle lever, transmission gear lever in NEUTRAL and especially check if parking brake is applied.
- Lower the implements on the ground.
- Ensure that rear view mirrors and the other mirrors (if fitted) are adjusted correctly, and check the operation of the headlights and other lights.
- For driver’s safety, to prevent an unintentional start, movement and operation, several and various start-safety interlock devices may be equipped on your tractor. And, these installation may need to do correct operation and follow the procedure strictly. Read carefully chapter 4-2, “Engine start and stop” in this manual before trying to start engine.
- Do not short across the starter motor terminals to start engine. It may cause a sudden start and serious injury or death.



► Do not start the engine in a closed area. The poisonous exhaust gas can cause fatal damage to the driver or persons around.

### (3) Notices while operating/using the tractor

#### ● Ventilation

 Warning	<p>► It is very dangerous to work in a closed area. The poisonous exhaust gas may cause serious damage to the human body. If you should work in this area, make sure to ventilate well and put on the protective mask.</p>
	

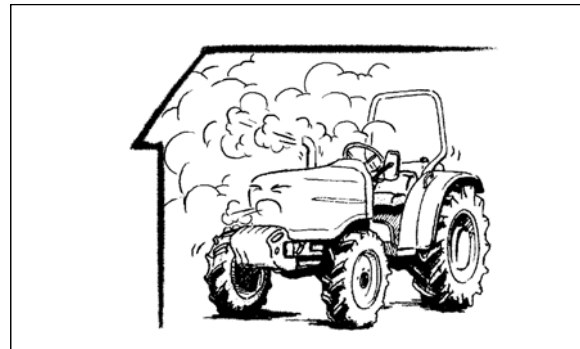

- **Noise and Vibration** : When working between buildings or in confined spaces, the sound pressure level can be increased. Wear suitable ear protectors in high noise level conditions. When working with equipment in the field, vibration intensity from equipment may be increased. To reduce the harm to the body, take a rest periodically.

- Connect left and right brake pedal(s) while driving on the road. (if fitted)
- DO NOT use differential lock device while driving on the road or turning in the field.
- DO NOT ride your foot on the brake pedal(s) or clutch pedal.
- Do not jump up/down while tractor is moving. When getting on/off the tractor, use the grab rail and sub step to prevent falls.
- Lower the driving speed enough before turning a sharp curve. Especially, when you drive the tractor with implements, make the turning radius wider.
- DO NOT start or stop the tractor suddenly. Engage the clutch and brake softly. If not, front wheels can be lifted up and it is very dangerous.
- While working, you must clean the spraying area, front/rear wheels, axles, mud guards and fenders regularly.

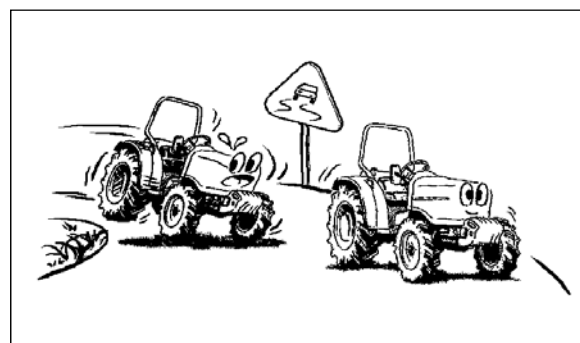
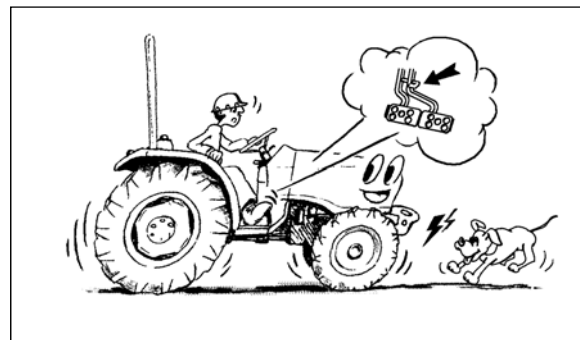

- When driving the tractor in reverse, lower the engine speed. Make sure to check if there is any obstacle or person in the rear.
- DO NOT permit other people and especially children approach within working area while operating tractor and equipment.

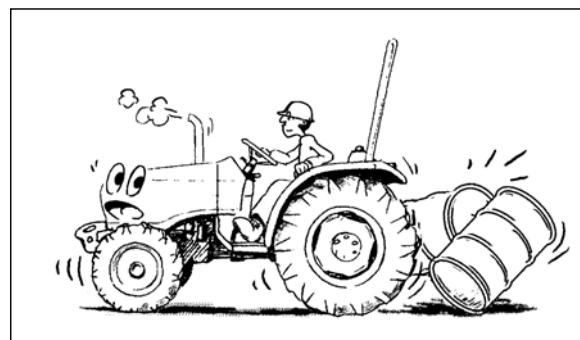

- Obey the traffic rules while driving on public roads. Do not exceed the local legal speed limit. Use a beacon or slow moving vehicle (SMV) to indicate that the vehicle is slow moving.
- If you can not drive the tractor due to a failure, move the tractor to a safe place and install troubled vehicle (safety tripod).  
(Day : backward 100m ( 328 ft )  
Night : backward 200m ( 656 ft))

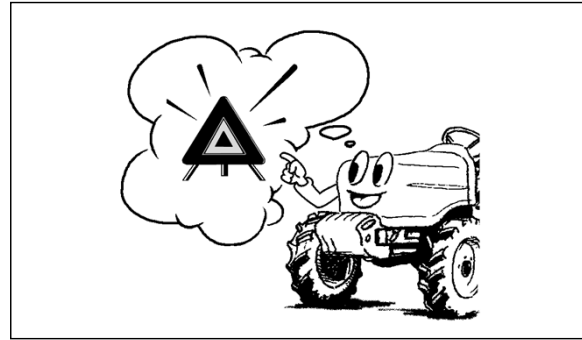

- Do not overuse the fuel, oil, etc and pay attention not to contact the skin directly. Generally, these materials contain harmful materials to the human body. When you work in a area where hazardous chemicals are sprayed, check the cabin filter (if fitted) and replace the filter with suitable one for the purpose being used. To protect the body completely from these harmful materials, wear a safe protection equipment such as mask, and clean the body after working.
- When crossing a high ridge, let down the implement and go straight across the ridge at low speed.

- When connecting the implements to the front/rear of the tractor, install the proper additional weights in the rear/front of the tractor to keep the balance of the tractor.
- On a downhill, operate the throttle pedal and brake pedal slowly and DO NOT drive while the transmission gear is in NEUTRAL.

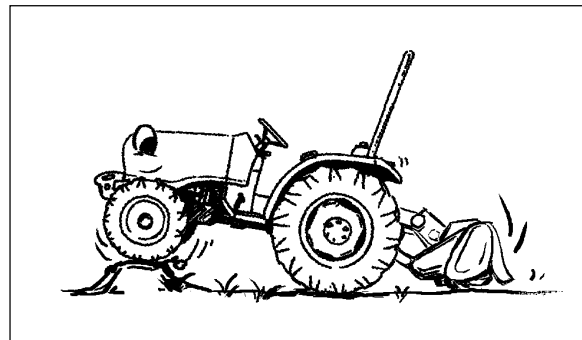

- *When working with a front/rear implement, be careful not to touch the overhead power lines and hanging obstacles.*
- *Do not operate the tractor during an electrical storm. (Lightening strikes)*

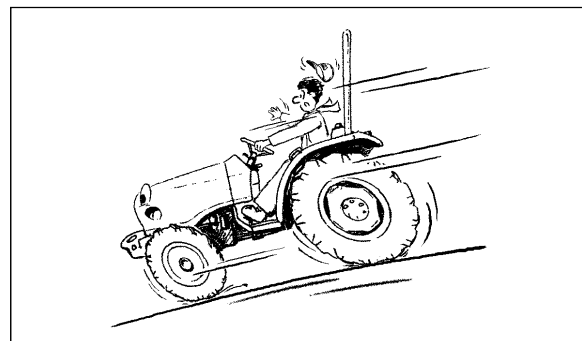

- To climb a steep slope, drive tractor slowly in reverse up the slope rather than forward. It is much safer.
- When turning tractor on a slope, the tractor can be overturned easily. Pay attention to the steering operation.
- When working at the edge of steep slope, especially, when using heavy attached implements, take special care about a turn-over.
- When working, wear the protection equipment and tighten the seat belt.
- If the authorized passenger seat are not installed, keep riders off.

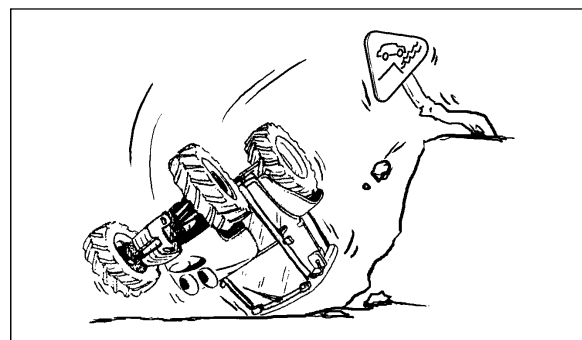



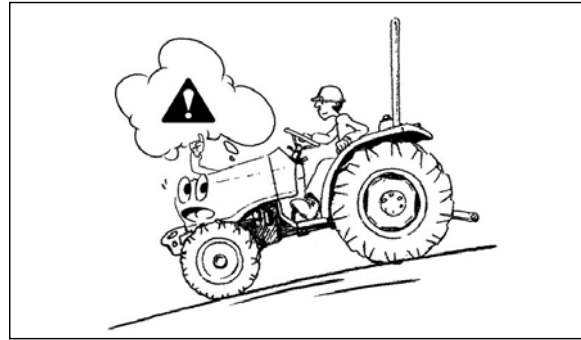

- Do not operate the product beyond its **limits of terrain gradient** and stability than outlined in this manual. Using the tractor beyond these limits may cause a serious accident or death.
- **The steering system of your tractor may be locked at steep slopes of more than 25 ° downhill.** If you need to work on a slope of 25 ° or more, add transmission oil until the oil level is marked over 1~2cm of the upper limit scale of the transmission oil level gauge. And, make sure to check that the steering wheel works smoothly at an inclination of 30 ° or more.



## (4) Notices when connecting Implement

- Attach or detach the implement on wide and level ground.
- Do not use the tractor in combination with equipment arbitrary, without having consulted the specific operator's manual provided with the equipment.
- You have to stay clear from the three-point linkage when controlling it. Do not stay between tractor and implement.
- Do not stay between tractor and trailed vehicle for connecting/disconnecting or checking it. Trailed vehicle may roll down or tractor can move reverse.
- When towing the trailed vehicle, use only hitch or drawbar. Do not tow by connecting with any other structures.
- When connecting heavy implements, apply the parking brake and use the wheel chock.
- Do not attach over-weighted implement.



 <p>Caution</p>	<ul style="list-style-type: none"> <li>▶ When connecting or disconnecting hydraulic coupler, lower implement on the ground, turn off engine and check if the pressure of hydraulic line is released.</li> <li>▶ When installing the implement having big hydraulic cylinders or lines, check the oil level in the transmission housing after installing the implements.</li> </ul>
 <p>Warning</p>  	<ul style="list-style-type: none"> <li>▶ Before connecting or checking the implement, put PTO switch to "OFF" and place PTO gear lever in Neutral position.</li> <li>▶ When attaching or detaching the implement, make sure to fix the implement and tighten the three point hitch pins correctly. If not, the serious troubles and injury can occur during the operation.</li> <li>▶ If heavy loaded trailer is connected to 3-point linkage or any structure, it can cause turnover or failure and serious injury. Make sure to use towing hitch or authorized draw bar.</li> </ul>

## (5) Notices when towing the tractor

- If your tractor needs to be towed for a short distance, use the hitch (or drawbar) or front towing hook. Do not connect to other structures such as rear axle, ROPS, front axle, steering components for towing.
- Your tractor can be steered for a short distance without engine running, but it will be hard to turn the steering wheel. If possible, run the engine for steering and lubrication.
- When being towed, disengage the 4WD, differential lock, parking brake and place all gear shift levers in neutral position.
- Check the horizontal and vertical permissible load of the hitch (or drawbar) before towing. The load is different with trailer brake, and stopping distance increases with speed and weight of towed loads and slope. Make sure you consider the total weight of the equipment and its load. (See chapter 4-5-(3). "Hitch and Drawbar" in this manual. )
- Drive slowly when towing extremely heavy loads.
- Do not tow trailers that are not fitted with an independent braking system.

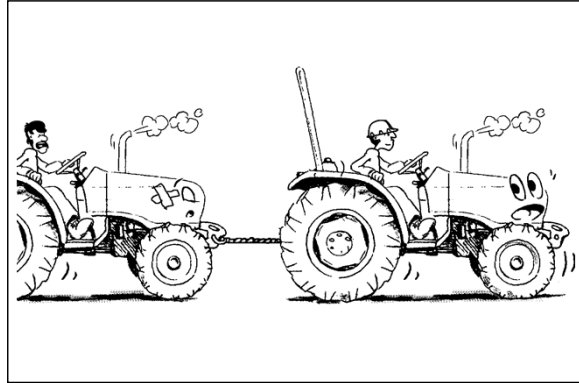

## (6) Notices when transporting the tractor

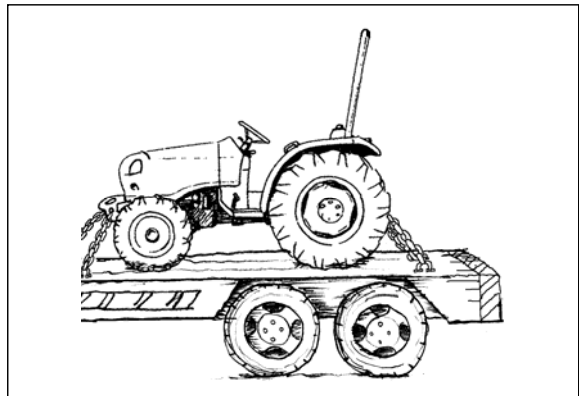

- When transporting the tractor by truck, trailer, etc., use suitable equipment or facilities to load or unload the tractor.
- Fix the tractor tightly to the vehicle with heavy-duty straps or chains.
- When fixing the rear of the tractor, use the hitch or hitch support.
- When fixing the front of the tractor, use the towing hook.
- When driving on public roads, the transporting vehicle must have signs and lights required by local regulation to avoid collision with a vehicle.



 <b>Caution</b>	<ul style="list-style-type: none"><li>▶ When fixing the tractor, do not hook or connect chains to the 4WD shaft, steering cylinder, tie-rod or front axle. These can be damaged by the chain or excessive strain.</li><li>▶ In case of turbocharger engine (where fitted), cover the exhaust outlet to protect that the turbocharger does not rotate by air without lubrication.</li></ul>
--	--



## (7) Notices when servicing the tractor after work

- Check and maintenance must be performed after **stopping the engine** and **cooling down the engine sufficiently**.
- **DO NOT** pour water into the radiator or engine when engine is hot. The engine or radiator may crack.

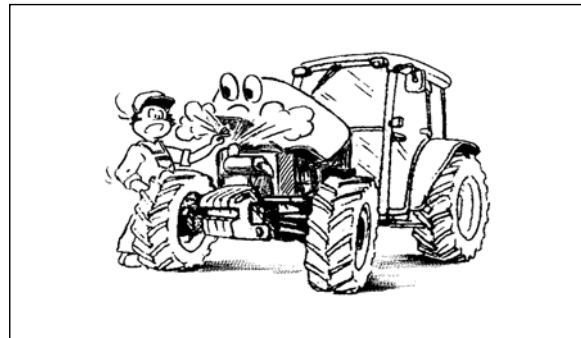

 Warning	<p>▶ When opening radiator cap, hot cooling water or steam may explode. Remove the cap using a thick rag or glove to prevent serious burns.</p>
	



- **Remove all mud and debris** from the tractor after working. Especially check the engine area and exhaust system.
- Before checking or repairing hydraulic system and fuel system, make sure the **engine is stopped, and all the transmission gears are in neutral, and lower the implements to the ground**. The leaks of pressurized fluid can cause a fatal physical injury. If injured by leaking fluid, get medical attention immediately.

 Warning	<p>▶ Before removing hydraulic pipes or hoses and other parts, make sure to check that hydraulic pressure is relieved completely. The leaks of pressurized oil can cause a fatal physical injury.</p>
	<p>▶ Use proper protection equipment, before servicing hydraulic system.</p> <p>▶ Before connecting or disconnecting the hydraulic quick coupler, lower the implements to the ground, and check that hydraulic pressure is relieved.</p>

- **Keep an approved fire extinguisher and First-aid-kit** on your tractor.
- **To prevent an fire or explosion of the battery**, keep any type of flames or sparks away from battery. Do not grind, smoke, or weld near a battery. Do not short circuit the terminals with metal objects. *For further information, see chapter 5-14-(5), "Battery handling and Notices" in this manual.*

 Warning	<p>▶ <b>Always remove grounded (-) battery clamp first and assemble it last.</b></p>
	<p>▶ <b>Sulfuric acid in battery electrolyte is poisonous.</b> It is strong enough to burn skin, clothing and can cause blindness if splashed into eyes</p> <p>▶ Battery post, terminals and related accessories contain <b>lead and lead compounds. MUST WASH YOUR HANDS AFTER HANDLING.</b></p>

- Do not attempt to **remove or unfasten the air conditioning components(if fitted) arbitrary**. There is a possible to be severely frostbitten or injured by escaping refrigerant. Contact your authorized local dealer to work air conditioning systems.
- **Keep the area used for servicing the tractor clean and dry**. Wet or oily floors are slippery. It can be dangerous when working with electrical equipment.
- When lifting heavy parts like engine, axle, tires etc., make sure to **check the lifting facilities have enough strength and capacity**.

- Before servicing the tractor, attach a “**DO NOT OPERATE**” warning tag to the tractor in an area that will be visible.
- Electric sensors, switches, harness, involving engine control unit(if fitted) is very sensitive and delicate. Strictly **prohibit injecting water, mechanical impulse and any kind of welding on engine.**

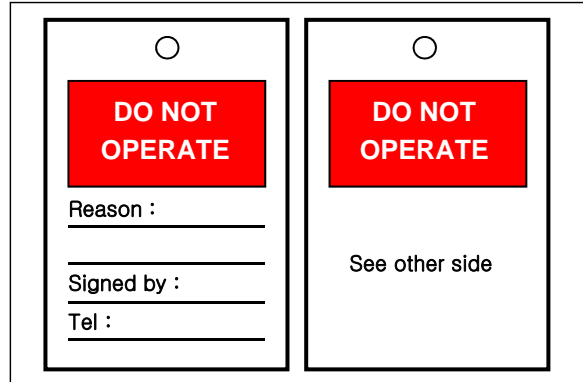

- *When assembling, operating, or servicing the tractor, wear protective clothing and any Personal Protective Equipment (PPE) necessary for the particular procedure. The necessary PPE may include: - Protective shoes, Eye and/or face protection, Hard hat, Heavy gloves, Filter mask, Hearing protection.*
- *When tractor maintenance requires you to work at heights:*
  - *Correctly use tractor steps, ladders, and/or hand holds.*
  - *Do not stand on tractor areas that are not designed as steps or platforms.*
  - *When necessary, use an appropriate ladder to reach components such as mirrors, rotating beacons, or air filters.*
  - *Never use steps, ladders, and/or hand holds when the tractor is in motion.*
  - *Do not use the tractor as a lift, ladder, or platform for working at heights.*
- *If you do not understand a maintenance procedure, or doubt your ability to perform a maintenance procedure correctly, see your authorized dealer.*

## (8) Notices when handling Diesel Fuel

- *Before handling diesel fuel, refer to the chapter 5-1-(3), 5-1-(5) in this manual.*
- *Before handling Bio-diesel, refer to the chapter 5-1-(4) in this manual.*





 <b>Warning</b>	<p><b>Fire hazard!</b></p> <p>► When handling diesel fuel, observe the following precautions:</p> <ol style="list-style-type: none"> <li>1. Do not smoke. Keep any type of flame away.</li> <li>2. Never fill the tank when the engine is running.</li> <li>3. Wipe up spilled fuel immediately. Always tighten the fuel tank cap securely.</li> </ol> <p>Failure to comply could result in death or serious injury.</p>
--	--

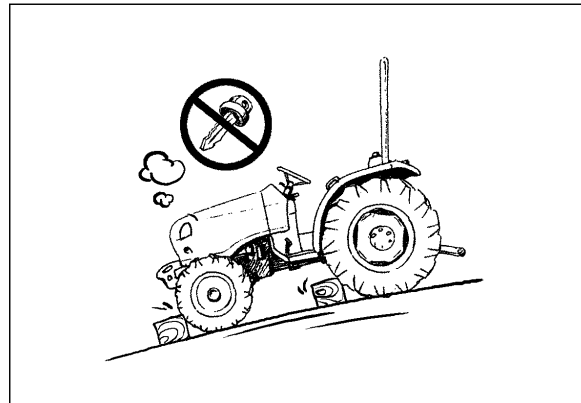

## (9) Notices when leaving the tractor

- Stop the tractor on level ground.
- Place the transmission gear in neutral and put PTO switch to “OFF” position.
- Lower the mounted implements on the ground.
- Apply the parking brake.
- Stop the engine and remove the ignition key.
- Before you leave the operator’s station, wait for engine and all moving parts to stop.
- Apply wheel chocks to the wheels when parking the tractor on a slope unavoidably.



 <b>Caution</b>	<p>► If it is necessary to park your tractor on a slope, furthermore with a loaded trailer, the tractor may roll down even if the parking brake is applied. In this case, additionally apply the lowest transmission gear and apply wheel chocks or blocks to the all tires.</p> <p>- . <b>Mechanical: downhill</b> ⇒ <b>Reverse 1<sup>st</sup> gear</b> / <b>uphill</b> ⇒ <b>Forward 1<sup>st</sup> gear</b></p> <p>- . <b>Power shuttle: Engine brake by transmission gear is NOT available.</b></p>
--	--

## (10) Notices relating to Toxic substances

 **WARNING:** Breathing diesel engine exhaust exposes you to chemicals known to the State of California to cause cancer and birth defects or other reproductive harm.

- Always start and operate the engine in a well-ventilated area.
- If in an enclosed area, vent the exhaust to the outside.
- Do not modify or tamper with the exhaust system.
- Do not idle the engine except as necessary.
- Battery post, terminals and related accessories contain lead and lead compounds.
- When handling engine oil, diesel fuel, anti-freeze solution and other chemical substances, wear protective clothes, mask and gloves.
- For more information, go to [www.P65warnings.ca.gov/diesel](http://www.P65warnings.ca.gov/diesel)

**WASH YOUR HANDS AFTER HANDLING.**

## (11) Tractor stability

 Warning	<p>▶ <b>Driving hazard!</b></p> <p><b>To prevent tractor instability, ALWAYS consider and follow the tractor stability requirements in this manual.</b></p> <p><b>Failure to comply could result in death or serious injury.</b></p>
---	--

The following procedure describes the requirements for tractor stability and how to calculate the required front-mounted and rear-mounted ballast.

For additional ballast information, also refer to the ballast recommendations in this manual.

For the maximum permitted operating weights, refer to the vehicle weights in this manual.

The following procedure and calculation is based on a tractor on even ground.

 Warning	<p>▶ <b>Roll-over hazard!</b></p> <p><b>ALWAYS be aware of the effect of inclines and steep hills on tractor stability. Operating, handling, and braking performance may be affected.</b></p> <p><b>Adjust ballast and driving speed accordingly to ensure stable and accurate steering, and to ensure the required brake performance in critical situations.</b></p> <p><b>Failure to comply could result in death or serious injury.</b></p>
---	--

## Necessary data to evaluate stability

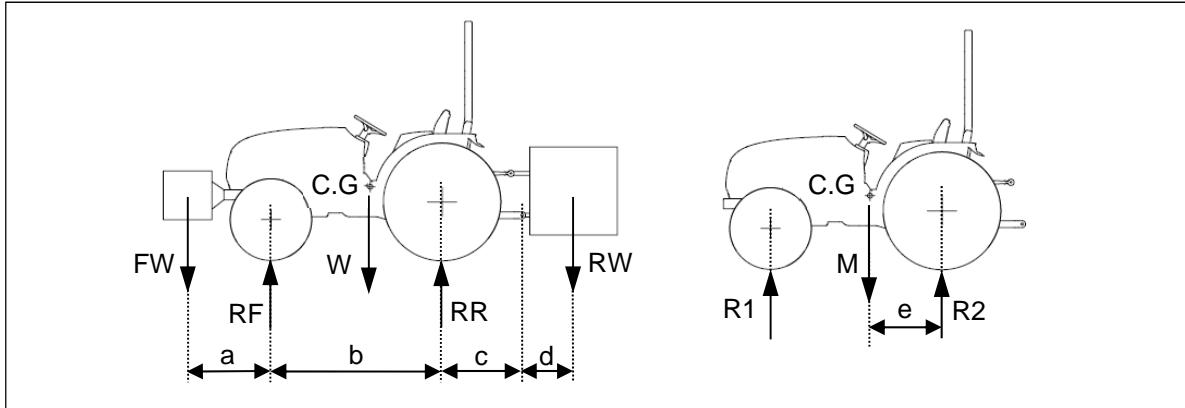

		To get this value refer to:
M	Mass of the unladen tractor = Tractor with standard equipment, minimum fuel, no weights or liquid ballast, no operator, and single wheel equipment	See chapter 7 in this manual.
R1	Front axle load of unladen tractor	See chapter 7
R2	Rear axle load of unladen tractor	See chapter 7
a	Distance, Center of gravity of front load to front axle center	Manual of the equipment or your measurement
b	Wheelbase	See chapter 7
c	Distance, rear axle center to lower hitch point of three-point linkage	See chapter 7 or your measurement
d	Distance, Center of gravity of rear load to lower hitch point of three-point linkage	Manual of the equipment or your measurement
e	Distance, rear axle center to center of gravity of mass of the unladen tractor (M)	Calculate using formula on the following pages
FW	Mass of front-mounted equipment or front-mounted ballast	Manual of the equipment or your measurement
RW	Mass of rear-mounted equipment or rear-mounted ballast	Manual of the equipment or to measurement
Wmax	Maximum permissible mass of the laden tractor	See chapter 4-5-(4)
RFmax	Maximum permissible front axle load	See chapter 4-5-(4)
RRmax	Maximum permissible rear axle load	See chapter 4-5-(4)

1. Equipment weight together with its filling must be added to laden values (seed drills, fertilizer spreaders, etc.).
2. Ballasting weight in the center of the front or rear tires, either solid or liquid, must be added to R1, R2, and M.
3. In case of an unbalanced trailer, the value c is the distance between the center of the rear axle and the hitching point, the value d is 0, and RW is the vertical load of the trailer on the hitch.

### Constant parameters

0.2	Minimum ratio: actual axle load of laden front axle/ mass of the unladen tractor	Legal requirement
0.45	Minimum ratio: actual axle load of laden rear axle/ mass of the unladen tractor	Legal requirement

### Required front ballast

To calculate	
FWr	Ballast required at the front when carrying a load RW at the rear
CALCULATION OF FWr	
$M * e = R1 * b$	
$e = (R1 * b) / M$	
$RW * (c + d) - (M * e) + (RF * b) = FWr * (a + b)$	
$RF > 0.2 * M$ RF value must be higher than $0.2 * M$	
$FWr > [RW * (c + d - (R1 * b) + (0.2 * M * b))] / (a + b)$	

### Required rear ballast

To calculate	
RWr	Ballast required at the rear when carrying a load FW at the front
CALCULATION OF RWr	
$M * b (b - e) = R2 * b$	
$FW * a - M * (b - e) + (RR * b) = RWr * (b + c + d)$	
$RW * (c + d) - (M * e) + (RF * b) = FWr * (a + b)$	
$RR > 0.45 * M$ RR value must be higher than $0.45 * M$	
$RWr > [(FW * a) - (R2 * b) + (0.45 * M * b)] / (b + c + d)$	

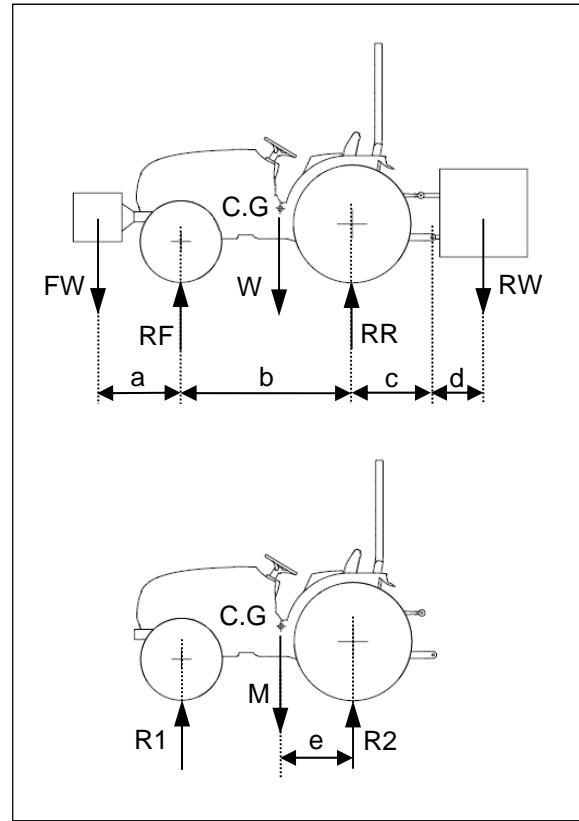

### Axle load limits

To calculate:	
RF	$RF < RF_{max}$
RR	$RR < RR_{max}$
W	$W < W_{max}$
CALCULATION OF RF	
$(RF * B) - FW * (A + B) - (M * E) + RW * (C + D)$	
$RF = [FW * (A + B) + (R1 * B) - RW * (C + D)] / B < RF_{max}$	
CALCULATION OF W	
$W = FW + M + RW < W_{max}$	
CALCULATION OF RR	
$R2T = W - RF < RR_{max}$	

## (12) Ecology and the environment

Soil, air and water is essential elements for human life. To contribute to environment preservation of the Earth, we are trying to minimize the environment pollution necessitated by general business activity such as product design, manufacturing, distribution, etc.

Several substances and products derived from chemical and petrochemical products are major portion of environment pollution and must be disposed of according to environment laws or related regulations, and common sense.

Familiarize yourself with the relative legislation applicable to your country, and make sure that you understand this legislation.

Where no legislation exists, obtain information from suppliers of oils, filters, batteries, fuels, anti-freeze, cleaning agents, etc., with regard to the effect of these substances on man and nature and how to safely store, use, and dispose of these substances.

We'd like to notify the following items for "Use & Disposal" related to environment preservation.

1. **Avoid the overload work** after reading the operator's manual.  
Overload work may reduce the life of the product as well as the unburned exhaust gas occurred during overload work becomes the major cause of air pollution.
2. When you replace various oils (engine oil, transmission oil, brake oil, and anti-freeze solution) directly, **do not throw the exhausted waste oil to any place.**  
This may pollute the soil and water seriously and also is prohibited legally. If violating, you would be responsible for that by civil or criminal case. The waste oil must be disposed according to the environment laws.
3. Use the product according to the operator's manual and if the life of product ended, do not throw away (or dispose) to any place. The rust water or oil coming from the disposed product may cause the pollution of soil or water. Thus, **the wasted product must be disposed lawfully,** contact your authorized local dealer nearby.
4. Modern lubricants contain additives. **Do not burn the disposed oil or fuel** in conventional heating systems.
5. When you replace the fuel, lubricants oil and coolants, avoid spillage and do not allow to be absorbed into the ground. Do not mix drained brake fluids or fuels with lubricants. They must be collected safely and disposed in a suitable manner.
6. **Do not adjust the setting of the fuel delivery system.** This will alter the emission of exhaust fumes. Do not increase the pressure in a pressurized circuit as this may lead to a component failure.
7. Do not open the air-conditioning system yourself. It contains gases that should not be released into the atmosphere. Your authorized local dealer or air-conditioning specialist has a special extractor for this purpose and can recharge the system properly.
8. Repair any leaks or defects in the engine cooling system or hydraulic system immediately.
9. In general, avoid skin contact with all fuels, oils, acids, solvents, etc. Most of these products contain substances that may be harmful to your health.



















































## Battery recycling

Batteries and electric accumulators contain several substances that can have a harmful effect on the environment if the batteries are not properly recycled after use. Improper disposal of batteries can contaminate the soil, groundwater, and waterways. We strongly recommend that you return all used batteries to a authorized local dealer, who will dispose of the used batteries or recycle the used batteries properly. In some countries, this is a legal requirement.



## (13) Symbols

The followings show the symbols and its meaning used for the tractor.

	Refer to operator's manual.		Gear Neutral		Low speed
	Caution!		Forward/Reverse		High speed
	Battery charging		Forward		Engine speed control (throttle)
	Fuel level		Reverse		Engine speed control (throttle)
	Fuel filter		4WD engage		Turn signal light
	Engine coolant temperature		4WD disengage		Light switch
	Hydraulic oil pressure		Quick turn (optional)		Side lights
	Engine oil pressure		Cruise drive (optional)		Headlights (Low beam)
	Engine preheat		Cruise drive release (optional)		Headlights (High beam)
	Parking brake		Position control (Up)		Work light
	Emergency lights		Position control (Down)		horn
	Engine start		Draft control (Deep)		Window wiper
	Engine stop		Draft control (Shallow)		Window wiper / Washer (front)
	PTO stop		Cylinder rod (shorten)		Window wiper / Washer (rear)
	PTO in operation		Cylinder rod (extend)		Unlatched brake pedal (optional)
	Differential lock device		Cylinder rod (floating)		Engine warning
	DPF regeneration		Exhaust gas temperature high		DPF inhibited

## (14) Safety Decals

### ① Handling and Maintenance of Safety Decals

- For intended use and personal safety of the operator, the safety decals (labels) are attached to the parts related with safety operation.
- Before operating or maintenance of the tractor, check the position and read the instructions carefully.
- If you find “Read Operator’s Manual” symbol (1) in the decals, refer to the appropriate page of the operator’s manual for further information regarding operation, adjustment and maintenance.

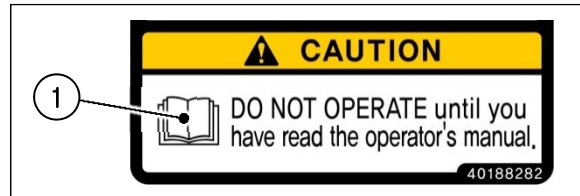

 Caution	<ul style="list-style-type: none"> <li>▶ The instructions described on the safety decals are very important for the safety of the operator and workers around. If ignored, it may cause the death or serious injury.</li> <li>▶ If the decals are dirty, wash them with soap water and wipe with soft rags. Do not use the thinner, acetone, or other harsh chemicals as it may erase the instructions.</li> <li>▶ If the decal is detached or damaged, replace it with a new one on original position.</li> <li>▶ When cleaning the tractor with pressurized water, the decals can be detached.</li> <li>▶ If a decal is on a part that is replaced, make sure the decal is attached on the new part.</li> </ul>
---	---

### ② Safety Decals and Attaching position

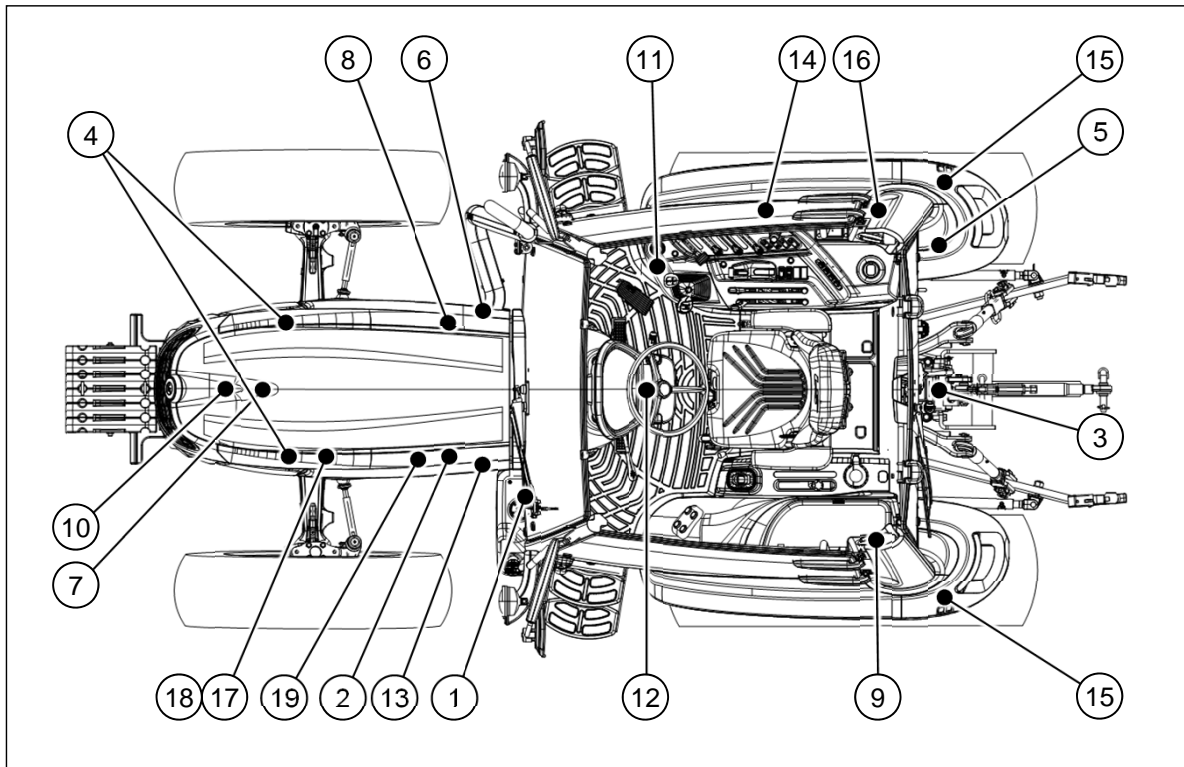



**1. Location : On the lower side of left-hand wind shield or door glass.**

- Only clean diesel fuel not contaminated.
- Ultra low sulfur diesel (S<10mg/kg).
- Do not smoke while refueling and keep any type of flame away.
- Maximum of 7% biodiesel(B7)
- Part No. : 40316391

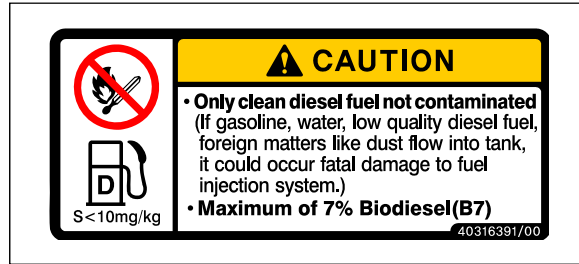

**2. Location : On the left-hand side of the starter motor cover.**

- RUN OVER HAZARD
- To prevent serious injury or death;
  - Start only from seat with transmission and PTO in neutral.
  - DO NOT short across starter terminals to start engine.
- Part No. : 40195651



**3. Location : On top of rear PTO guard.**

- Rotating driveline contact may cause serious injury or death.
- Keep all driveline, tractor and equipment shields in place during operation.
- Part No. : 40195650

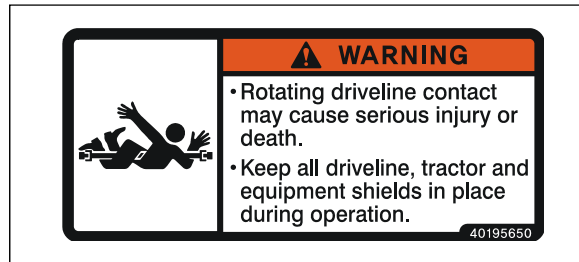

**4. Location : On the left/right-hand side of the fan shroud.**

- Keep hands clothing away from the rotating fan and belts.
- Contact with moving parts may cause loss of fingers or a hand.
- Failure to comply could result in death or serious injury.
- Part No. : 40239638



**5. Location : On the left side of the right-hand rear mud guard for cabin models.**

- HIGH PRESSURE FLUID HAZARD
- To prevent serious injury or death;
  - Relieve pressure on system before repairing, adjusting or disconnecting.
  - Wear proper hand and eye protection when searching for leaks, use wood or cardboard instead of hands.
  - If hydraulic fluid or fuel sinks into skin, seek medical attention immediately.
- Part No. : 40195652

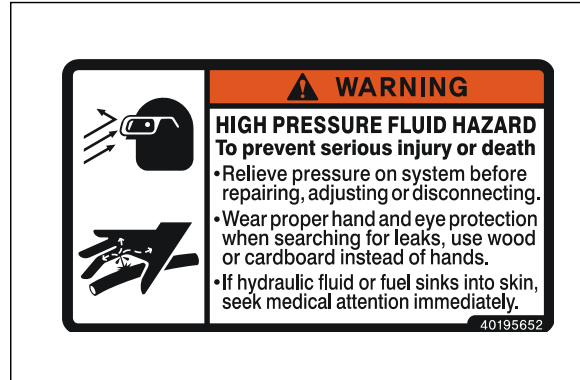

**6. Location : On the right-hand hood side cover**

- TO PREVENT DEATH OR SERIOUS INJURY
- During the DPF regeneration process, the exhaust stack and fixed hood area becomes extremely hot.
- Park the tractor away from highly flammable material and person.
- Part No. : 40342880



**7. Location : On top of radiator cap.**

- TO PREVENT DEATH OR SERIOUS INJURY;  
High pressure steam and hot water. Remove filler cap with extreme care.
- Failure to comply could result in death or serious injury.
- Part No. : 40297729



**8. Location : On the right-hand side of the DPF support.**

- TO PREVENT SERIOUS INJURY OR DEATH;  
Beware hot part. Keep clear of muffler to avoid injury.
- Failure to comply could result in serious injury.
- Part No. : 40239636







**9. Location : On the left-hand pillar for cabin models.**

**① CAUTION**

- PTO selector & lever must be in "OFF" position to start engine.
- Do not operate on hard surfaces with 4WD engaged.

**② WARNING**

- TO PREVENT SERIOUS INJURY OR DEATH;
- After first hour of operation and daily thereafter, check front and rear wheel lug nuts and bolts for proper torque.
- PTO - keep hands, feet and clothing away from PTO & other moving parts.
- Disengage PTO and shut off engine before servicing tractor or implements, or attaching / detaching implements.
- Keep all safety shields in place for your protection.
- Pull only from approved drawbar or lower links of 3-point hitch at horizontal position or below.
- Lock tractor brake pedals together for travel on roads or highways.
- Always apply parking brake and shift transmission to neutral before dismounting.
- Always use a seat belt when you operate the tractor.
- Allow no riders on tractor or implements.
- Do not use a seat belt when operating with folding ROPS in lowered position.
- Engine exhaust fumes can cause death or sickness. Always try to work in a ventilated area.
- Disengage the differential lock when turning the tractor. Always disengage the differential lock when driving on roads.
- Depress on or both brake pedals to disengage the differential lock.
- Failure to comply could result in death or serious injury.
- Part No. : 40360330

<b>⚠ CAUTION</b>	
<ul style="list-style-type: none"> <li>• PTO selector &amp; lever must be in "OFF" position to start engine.</li> <li>• Do not operate on hard surfaces with 4WD engaged.</li> </ul>	
<b>⚠ WARNING</b>	
<b>To prevent serious injury or death</b>	
<ul style="list-style-type: none"> <li>• After first hour of operation and daily thereafter, check front and rear wheel lug nuts and bolts for proper torque.</li> <li>• PTO-keep hands, feet and clothing away from PTO &amp; other moving parts.</li> <li>• Disengage PTO and shut off engine before servicing tractor or implements or attaching or detaching implements.</li> <li>• Keep all safety shields in place for your protection.</li> <li>• Pull only from approved drawbar or lower links of 3-point hitch at horizontal position or below.</li> <li>• Lock tractor brake pedals together for travel on roads or highways.</li> <li>• Always apply parking brake and shift transmission to neutral before dismounting.</li> <li>• Allow no riders on tractor or implements.</li> </ul>	
	<b>To prevent serious injury or death</b>
	<ul style="list-style-type: none"> <li>• Always use a seat belt when you operate the tractor.</li> <li>• Do not use a seat belt when operating with folding ROPS in lowered position.</li> </ul>
	<ul style="list-style-type: none"> <li>• Engine exhaust fumes can cause death or sickness.</li> <li>• Always try to work in a well ventilated area.</li> </ul>
	<ul style="list-style-type: none"> <li>• Disengage the differential lock when turning the tractor.</li> <li>• Always disengage the differential lock when driving on roads.</li> <li>• Depress one or both brake pedals to disengage the differential lock.</li> </ul>
40360330/00	

**10. Location : On top of ECU cover inside the hood.**

- CAUTION;  
Avoid direct water spray on ECU. It may cause problems.
- Failure to comply could result in malfunction of ECU.
- Part No. : 40283939

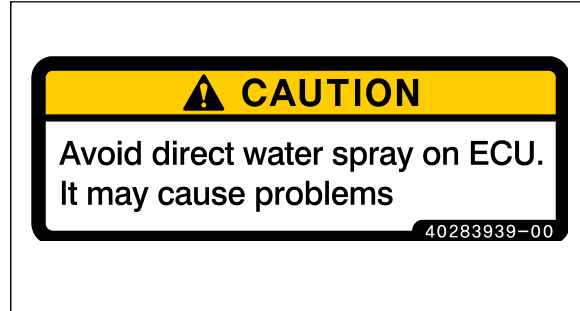

**11. Location : On the left-hand side of the joystick cover for cabin models. (optional)**

- JOYSTICK LEVER USAGE.
- TO AVOID PERSONAL INJURY; Wrong operation causes serious injury easily.  
Push the lever(1) into the lock position while not using.
- Failure to comply could result in death or serious injury.
- Part number : 40264867

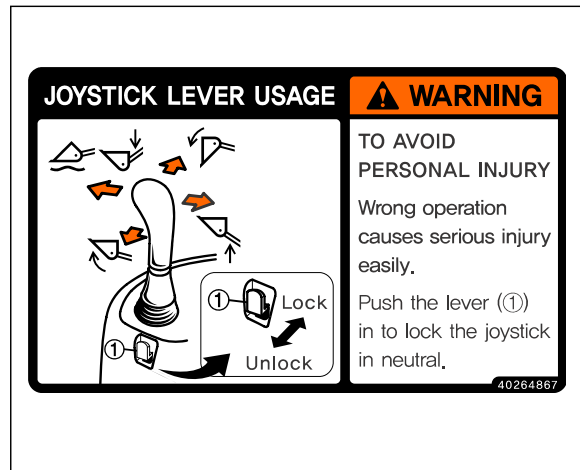

**12. Location : On the steel cover under the instrument console. (optional)**

- CAUTION.
- To prevent unnecessary wear, never ride the clutch pedal for resting a foot.
- Part number : 40222778



**13. Location : On the left-hand side of the hood cover.**

- CAUTION;  
Use of any engine oil other than CJ-4 may clog the DPF earlier than expected.  
Use only API CJ-4 engine oil.
- Failure to comply could result in malfunction of DPF.
- Part No. : 40342881

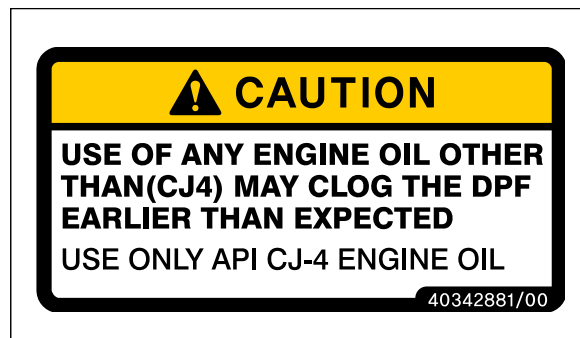

**14. Location: On the right-hand door glass for cabin models.**

- CAUTION;

Periodically, the DPF will require the regeneration. This is an automatic function unless inhibited by operator.

**1) Automatic :** The DPF regeneration lamp will illuminate indicating the regeneration is needed. If the operator does not inhibit the regeneration, the DPF temperature will also come on and the engine control unit will automatically begin the regeneration.

NOTE : Under light or no load conditions, increase the engine RPMs above 2,200rpm when possible.

**2) Inhibit :** In case the tractor is operated in extremely flammable materials, and the operator wishes to delay the regeneration process, press downward on the DPF switch for 1~2 seconds. The inhibit lamp will illuminate and the regeneration will be postponed.

**(Beware :** Inhibit is only intended for a few moments and the DPF must be regenerated. If the DPF lamp begins to blink, quickly move to a safe area, move the shuttle to neutral, apply the parking brake, bring engine to the lowest RPMs and press up on the DPF switch for 3 seconds. The inhibit lamp will go off and the engine control unit will begin the regeneration.)

**3) Forced Regeneration :** It is possible to force the regeneration before the soot is highly enough for automatic regeneration. To force the regeneration, shuttle to neutral, apply the parking brake, bring engine to the lowest RPMs and press up on the DPF switch for 3 seconds.

- Failure to comply could result in malfunction of DPF.

- Part No. : 40363308

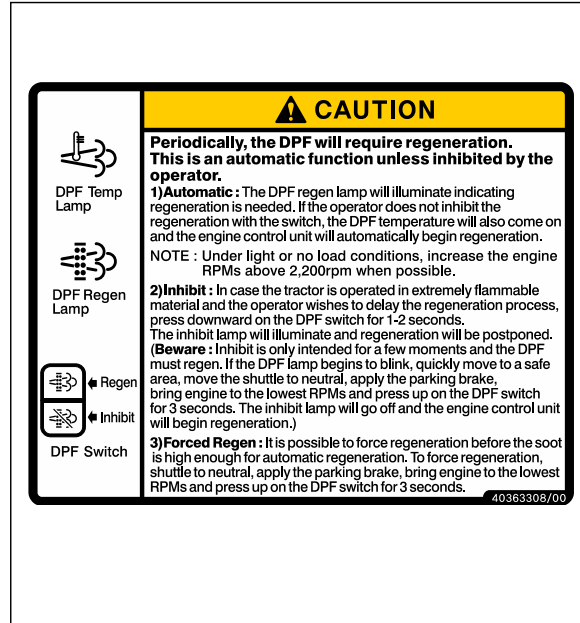

**15. Location: On the left / right-hand rear mud guard.**

- WARNING
- Avoid injury !
- Activate the external hydraulic control switches only while standing to the side of the machine (outboard of the tires).
- DO NOT stand on or near the implement or between the implement and machine.
- Failure to comply could result in death or serious injury.
- Part No. : 40269462



**16. Location: On the right-hand cabin pillar. (optional)**

- CAUTION;
- It may cause overheat.
- Return the lever to neutral after using detent.
- Failure to comply could result in malfunction of the hydraulic system and transmission.
- Part No. : 40199181 (optional)

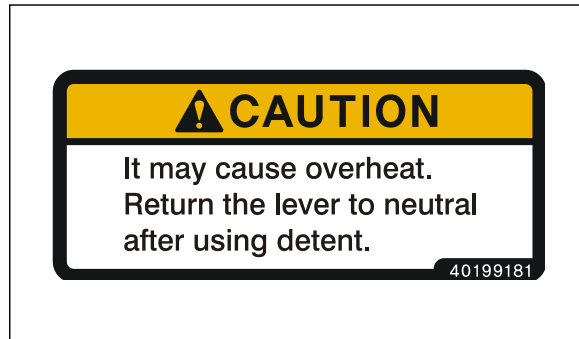

**17. Location: On the left-hand side of the radiator frame inside the hood. (Cabin models only)**

- WARNING;
- HFC-134a
- 0.8 kg
- 1.76 lb
- GWP: 1.144 TON
- Part No. : 40360032



**18. Location: On the left-hand side of the radiator frame. (Cabin models only)**

- WARNING;
- AIR CONDITIONING SYSTEM
- Fluid under high pressure.
- Do not disconnect any lines.
- Service, Repair or Recharging must be performed only by a trained service technician.
- Refrigerant: R-134a
- Failure to comply could result in serious injury or death.
- Part No. : 40323653



**19. Location: On the left-hand side of the engine oil pan.**

- WARNING;

Breathing diesel engine exhaust exposes you to chemicals known to the State of California to cause cancer and birth defects or other reproductive harm.

- Always start and operate the engine in a well-ventilated area.
- If in an enclosed area, vent the exhaust to the outside.
- Do not modify or tamper with the exhaust system.
- Do not idle the engine except as necessary.

For more information, go to [www.P65warnings.ca.gov/diesel](http://www.P65warnings.ca.gov/diesel)

- Part No. : 40401298

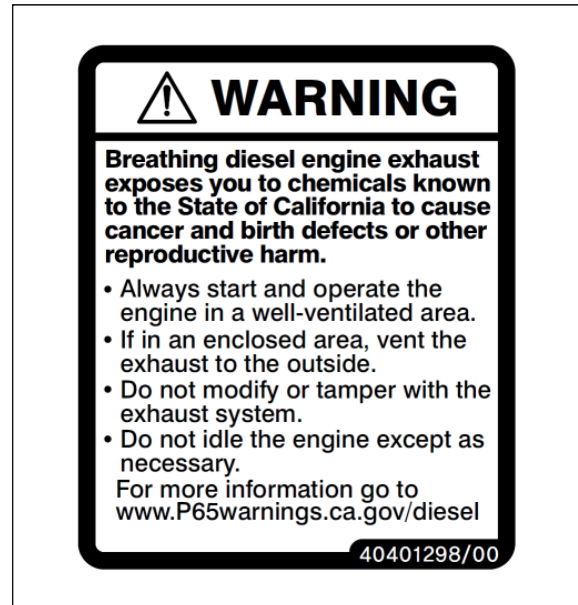

## (15) Instructional Decals

### ① Instructional Decals and Attaching position – Cabin model

The following instructional signs are placed on your tractor as a guide for your safety and for those working with you. Walk around the tractor and note the content and location of these instructional signs before operating your tractor.

Keep instructional signs clean and legible. Clean instructional signs with a soft cloth, water, and a gentle detergent. Do not use solvent, gasoline, or other harsh chemicals. Solvents, gasoline, and other harsh chemicals may damage or remove instructional signs.

Replace all instructional signs that are damaged, missing, painted over, or illegible. If an instructional sign is on a part that is replaced, make sure the instructional sign is installed on the new part. See your authorized local dealer for replacement instructional signs.

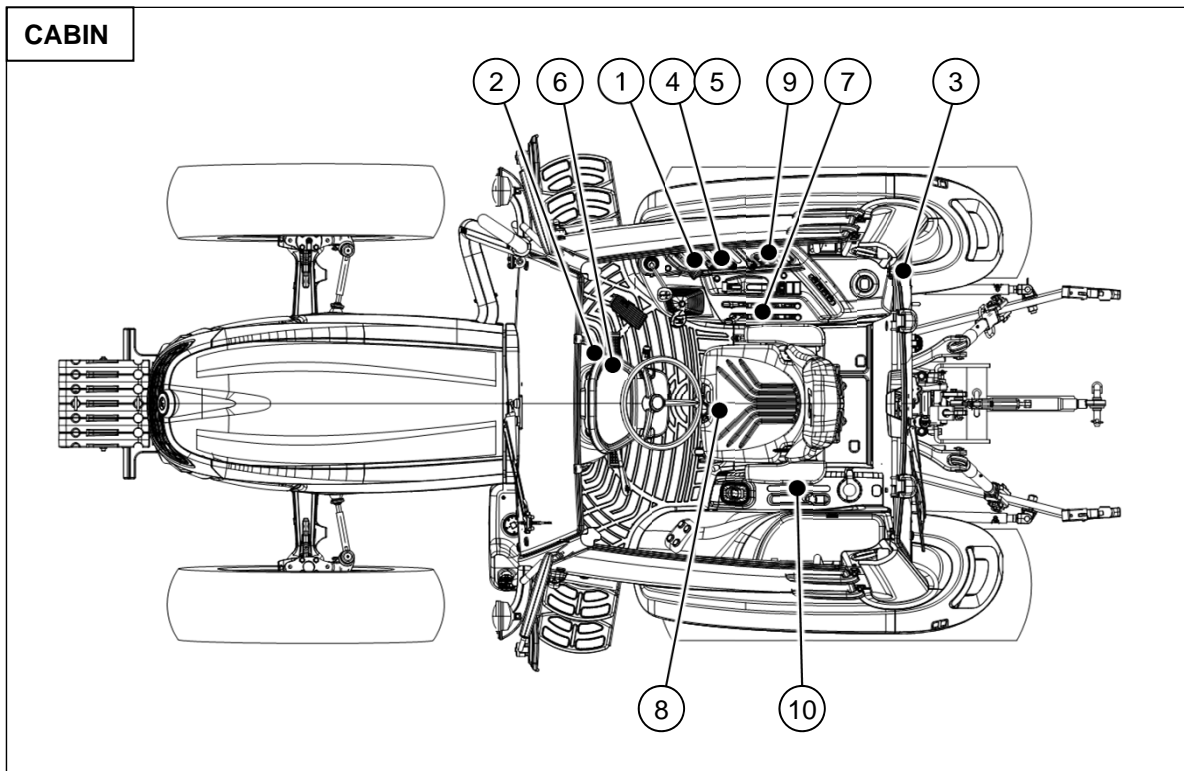



**1. Location: On the right-hand control panel cover.**

- Throttle lever.
- Part No. : 40233965



**2. Location: On the right-hand side of the body panel cover under the instrument panel.**

- Key switch.
- Part No. : 40008540

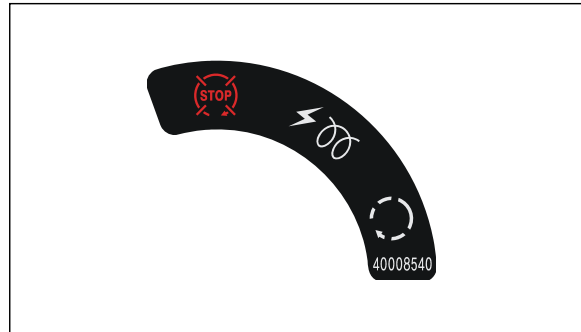

**3. Location: On the right-hand side of the cabin rear steel plate.**

- Remote valve quick couplers.
- Part No. : 40264365

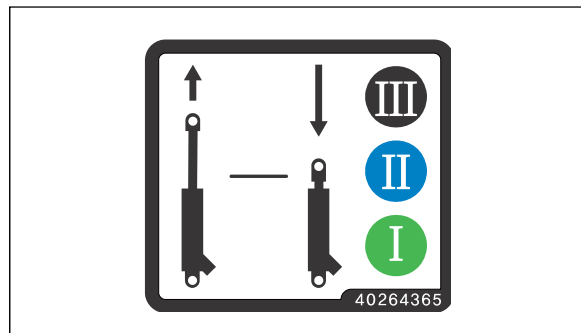

**4. Location: On the right-hand control panel cover.**

- Remote control lever.
- Part No. : 40315584

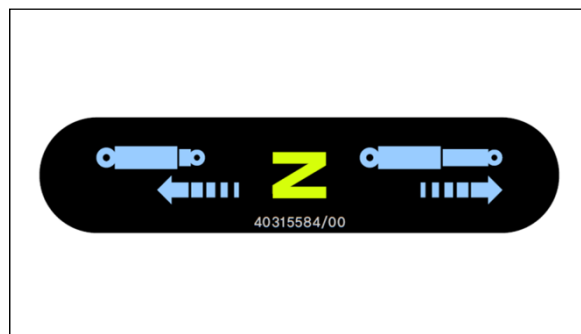

**5. Location: On the right-hand control panel cover.**

- Remote control lever.
- Part No. : 40315583
- It may vary depending on the market.(optional)

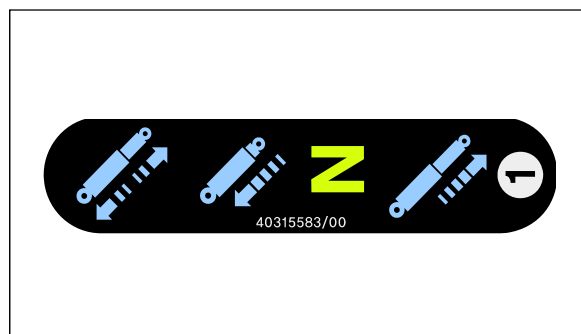

**6. Location: On top of right-hand instrument panel cover.**

- Start and stop of the turbocharger engine
- Part No. : 40394847

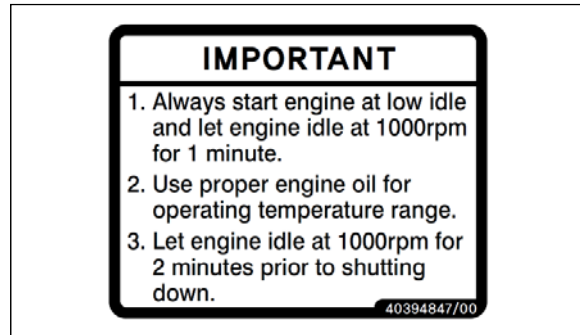

**7. Location: On the right-hand side lever guide.**

- Hydraulic lift control (position and draft control lever)
- Part No. : 40192090
- Mechanical Hydraulic Lift (MHL) models only

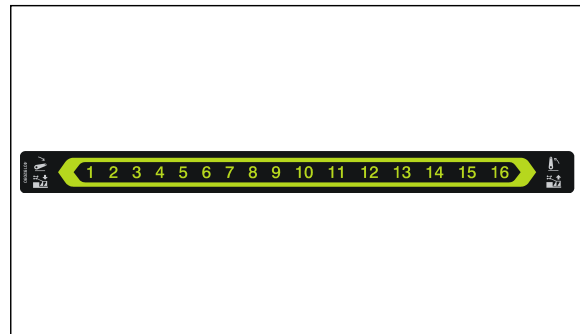

**8. Location: below the driver's seat.**

- Hydraulic lift control. (down speed control valve)
- Part No. : 40008821
- Mechanical Hydraulic Lift (MHL) models only

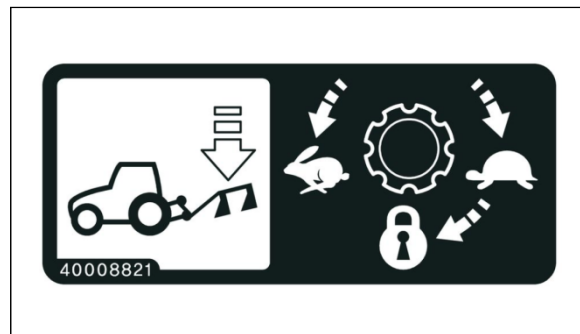

**9. Location: On the right-hand control panel cover.**

- PTO switch
- Part No. : 40324708

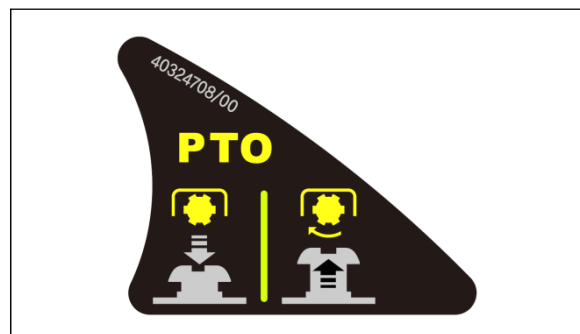

**10. Location: on the left-hand lever guide.**

- PTO gear lever
- Part No. : 40316387
- It may vary depending on the market.(optional)

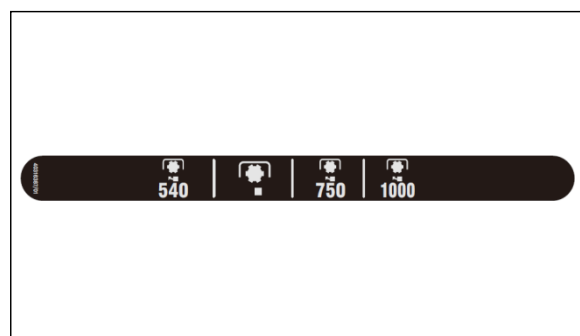

## 1-3. Long-term storage

### (1) Preparation for storage

※ Wash the tractor cleanly and follow the procedure as below.

- Apply grease or lubricant oil or spray paint to the non-painted metal to avoid corrosion. Keep the tractor in a covered, dry and well-ventilated place.

Temperature : 10°C ~ 35°C (50°F ~ 95°F)

Humidity : 45% ~ 70%

- Place all controls, including electrical switches, in neutral position and apply the wheel chocks to the tires and disengage the parking brake.
- Check the lubricant level of each parts and if the engine oil has exceeded 100 hours of work, change the oil and run the engine for 5 minutes at idle rpm.
- Drain engine coolant completely. If the engine coolant is anti-freeze solution, it is not necessary to drain but check its density.
- Fill the fuel tank full with fuel.
- Loosen all drive belts and clean the air cleaner.
- Loosen the rubber plug (if fitted) under the clutch chamber to drain water.
- Remove the battery, clean the cover and smear the terminals with grease. Place the battery in a ventilated place not less than 10°C (50°F) and away from direct sunlight.
- Remove the lift-rod and place the lift-arm to the highest position to lubricate the internal cylinder.
- Depress clutch pedal fully and apply the clutch pedal locker. This locker prevent clutch disk from sticking to engine. (Synchro-shuttle model only)

- If possible, fit stands or other suitable supports under the axles to raise the wheel off the ground. And let the air out of the tires. If not, check the tire pressure from time to time.
- Remove the ignition key.
- Cover the tractor with a non-water-proof cover.
- If the implements are attached, lower the implements on a support off the ground.

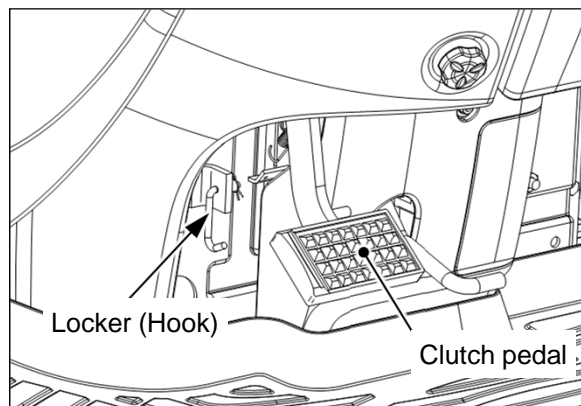
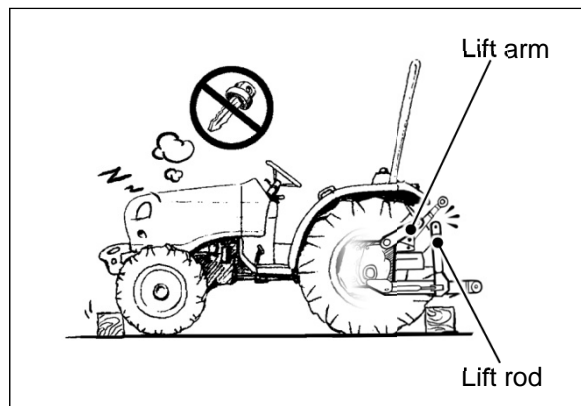
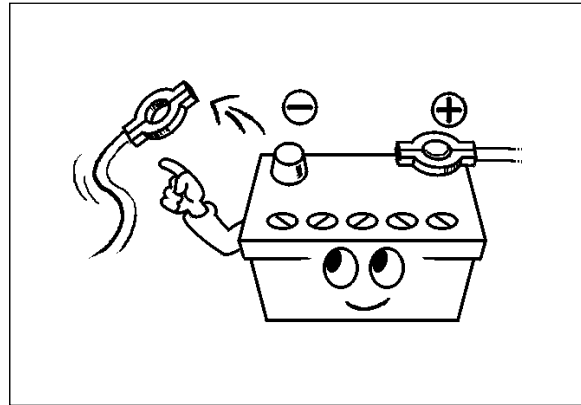

 Warning	<p>▶ When restarting engine at the end of long-term storage, follow the instructions of the “Preparation for Reuse” as below.</p>
---	---

## (2) Check & Maintenance during storage

- Apply grease or lubricant oil regularly to the non-painted parts.
- Check the leakage of fuel, oil and coolant. If necessary, repair the damaged part.
- Check if the tire air pressure is normal.
- **Start engine periodically for about 15 minutes, at least once a month** for circulation and lubrication in the fuel system and engine. This may vary depending on the engine, fuel system, fuel type and so on. Contact your authorized local dealer.
- The battery should be charged about once a month not to be discharged entirely.

 Caution	<p>▶ As the electrolyte of battery is sulfuric acid, it emits the explosive and poisonous gas. It is strong enough to burn skin, clothing and can cause blindness if splashed into eyes.</p> <ul style="list-style-type: none"> <li>- Keep the sparks and flames and cigarettes away from the battery.</li> <li>- When handling the battery, wear safety glasses to protect the eyes.</li> <li>- If the electrolyte contacts the eyes and skin, wash with water immediately and go to see a doctor.</li> </ul> <p>▶ When removing and storing battery, select dry and cool place out of reach of children.</p>
---	--

### (3) Preparation for Reuse

※ When using first after long-term storage, check each part as below.

- Inflate the tires to the recommended pressures and remove the blocking.
- Check the damaged part or loosen part.
- Check the leakage of fuel, coolant, engine oil, transmission and front axle oil.
- Check the level and density of the engine coolant.
- Check the level of engine, transmission, rear and front axle oil, and fuel.  
(For further information, refer to the chapter 5, "Lubrication and Maintenance" in this manual.)
- Check all drive belts carefully, paying particular attention to the point where the straight run of the belt starts to bend around the pulley. Check the vee groove in the pulley for corrosion.
- Electric system check
  - Is there any open circuit or any other problem in the wiring?
  - Is there any problem of the instruments?
  - Is the charging state of the battery sufficient?
- Depress the clutch pedal and disengage the clutch pedal locker. (Mechanical transmission models only)
- Start the engine and allow it to idle a few minutes. Ensure the engine is receiving lubrication and each control is functioning correctly.
- Run the engine at a fast idling speed (suggest 1000/1500 rpm) until normal operating temperature is registered, and check the surroundings for oil, fuel and coolant leakage.
- Drive the tractor without a load and check if the tractor is operating satisfactorily.

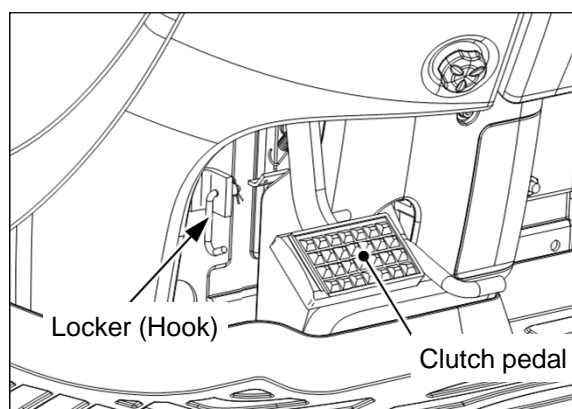



## 2. Instruction for Safe Operation

### (1) The name of each part

#### ① Cabin type

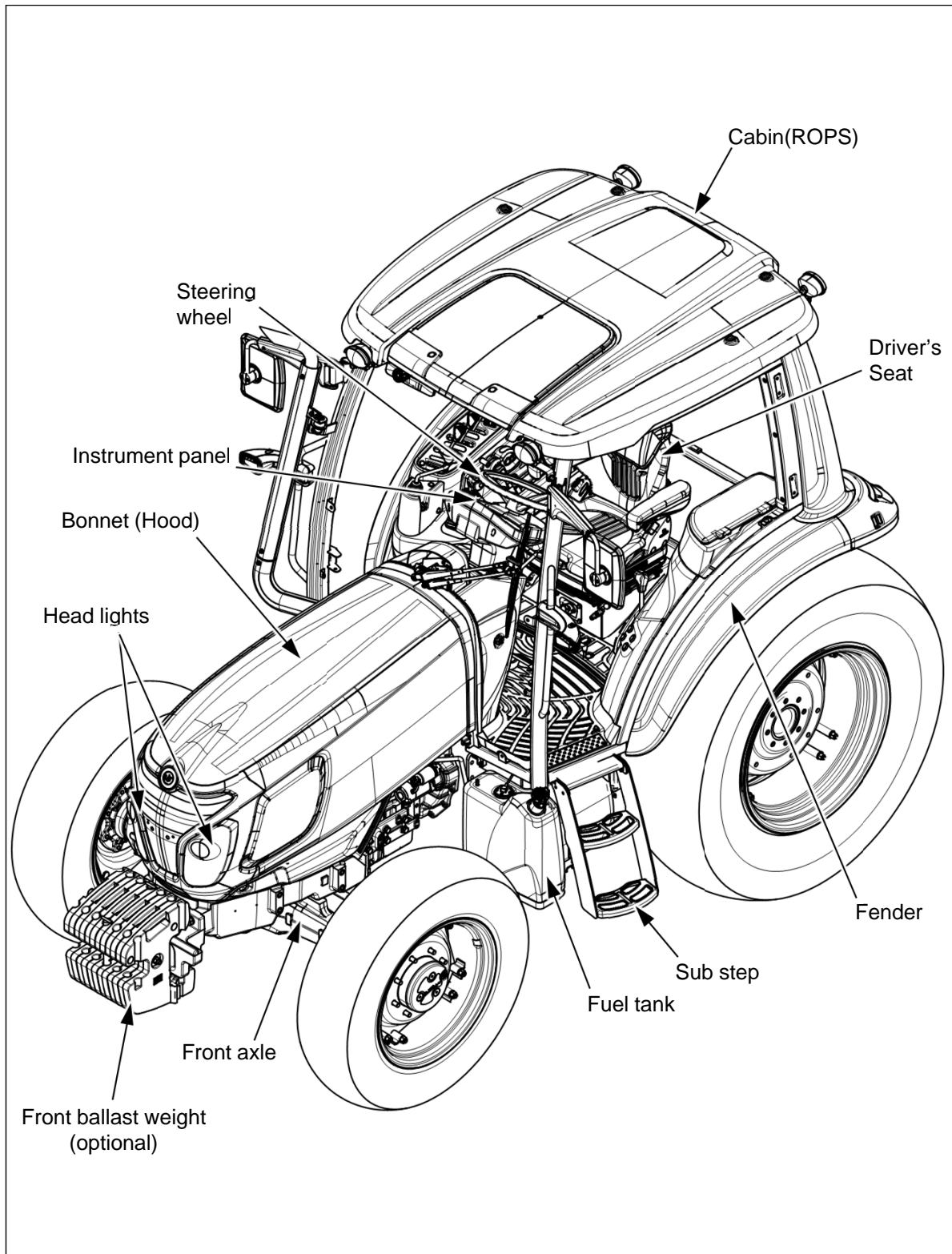



## 2-1. Boarding and Exiting the tractor

### (1) Boarding the tractor

#### ① Cabin type

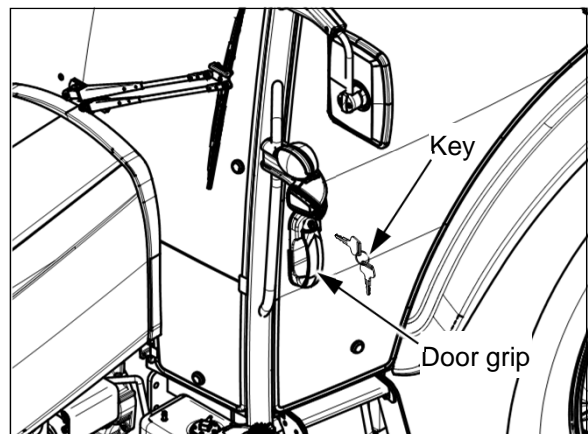
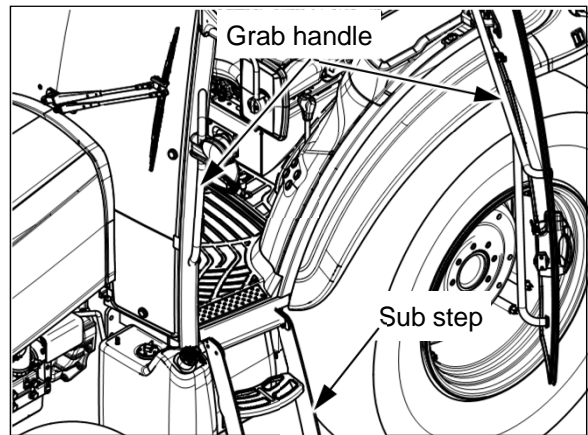
- Whenever possible, use the left-hand side door for entering.
- To enter the cabin, release the cabin door locked with the provided key and just pull the door grip.
- When boarding the tractor, use the sub-step, steering wheel, and grab handles provided on the cabin frame and door.
- Do not jump up/down for your safety. *Jumping on/off the tractor could cause an injury. Always face the tractor, use the handrails and steps, and get on/off slowly. Maintain a three-point contact to avoid falling: both hands on the handrails and one foot on the step, or one hand on the handrail and both feet on the steps.*
- When leaving the tractor, lock the cabin door and remove the key.



 Caution	<ul style="list-style-type: none"><li>▶ <b>Operator's condition</b> : The persons such as patients, drunks, people on drugs, etc. are never allowed to operate this tractor. Only well educated operators can use the tractor after learning the usage of controls for moving, stopping, turning and other operating.</li><li>▶ Do not grasp the gear levers when entering the cabin from the right-hand side.</li></ul>
---	--



## (2) Seat adjustment

### ① Standard type

- Before operating the tractor, adjust the position of driver's seat according to body size and length.

#### 1) Seat F/R adjustment lever

- After sitting on driver's seat, move the seat F/R adjustment lever up to release the lock.
- Move the driver's seat forward or backward depending on driver's body length.
- Release the seat F/R adjustment lever and check the seat is locked in place.

#### 2) Seat height adjustment knob

- If you turn the seat height adjustment knob clockwise, the seat height shall be lowered.

#### 3) Weight adjustment knob

- Adjust the seat suspension depending on your body weight by using the weight adjustment knob. If you turn the knob clockwise, the suspension stiffness shall be increased.

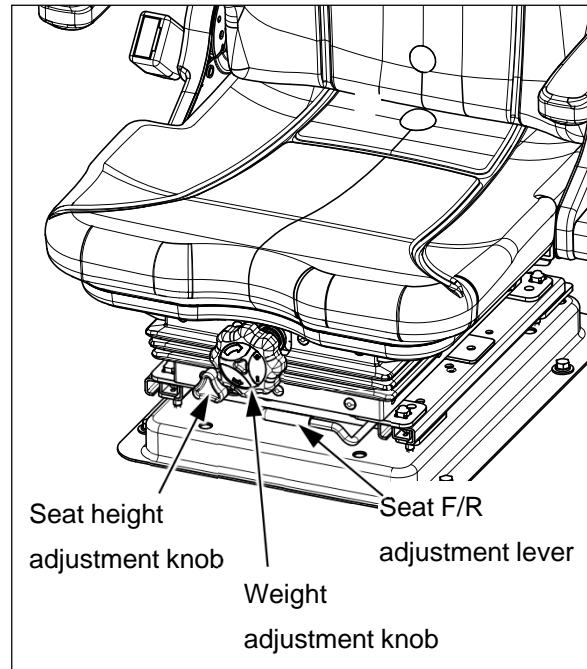

### ② Premium type (optional)

- Before operating the tractor, adjust the position of driver's seat according to body size and length.

#### 1) Seat F/R adjustment lever

- After sitting on driver's seat, move the seat F/R adjustment lever up to release the lock.
- Move the driver's seat forward or backward depending on driver's body length.
- Release the seat F/R adjustment lever and check the seat is locked in place.

#### 2) Seat swivel adjustment lever

- Pull the seat swivel adjustment lever to release the lock and rotate the seat to the right side.
- Release the lever and check the seat locked in place.
- The swiveled position is allowed only while operating in the field, and so return the seat to the neutral position before driving on load.

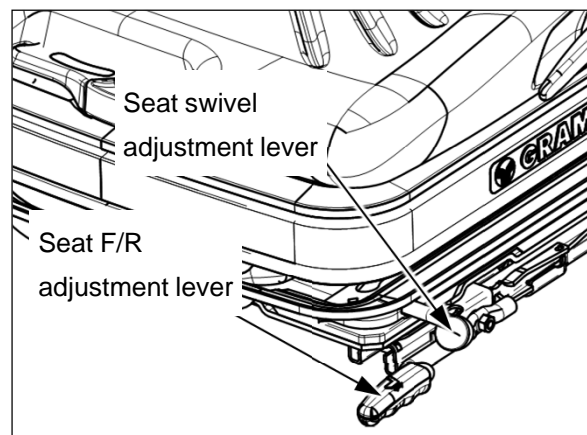

## ② Optional - continued

### 3) Weight adjustment lever

- PUSH the lever downward for light weight.
- PULL the lever upward for heavy weight after turning key switch to "ON" position.

### 4) Backrest angle adjustment lever

- Lift the lever upward to adjust the backrest angle.
- After adjusting, release the lever and check the backrest locked in place.

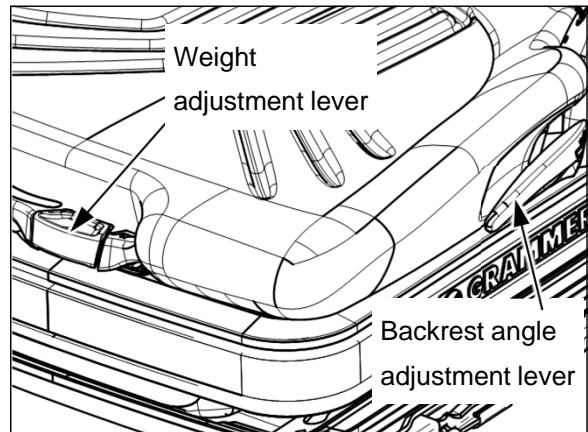

### 5) Armrest angle adjustment wheel

- It is used to lower/lift the armrest.
- Rotate the wheel inside to lower the armrest.
- Rotate the wheel outside to lift the armrest.

### 6) Backrest extension adjustment

- Pull or push down the backrest to fit your body.

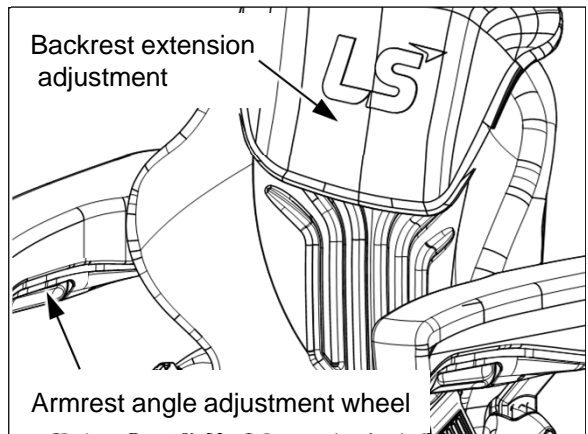

### 7) Lumber support adjustment lever

- Turn the lever counter-clockwise to raise the height of the lumbar support.
- Turn the lever clockwise to lower the height of the lumbar support.

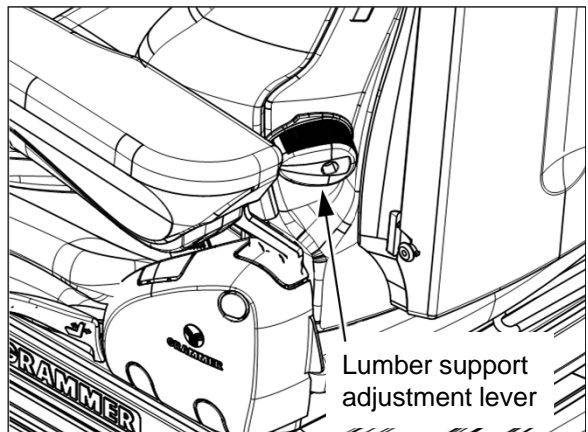



- ▶ DO NOT put your hand under the driver's seat while sitting. It may cause a injury by seat suspension.
- ▶ DO NOT adjust the seat position while driving.

### (3) Seat belt

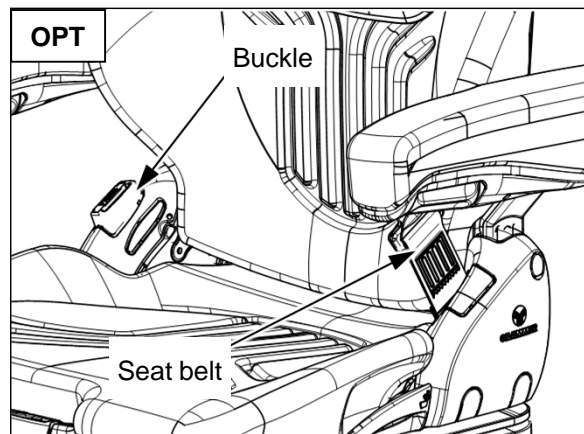
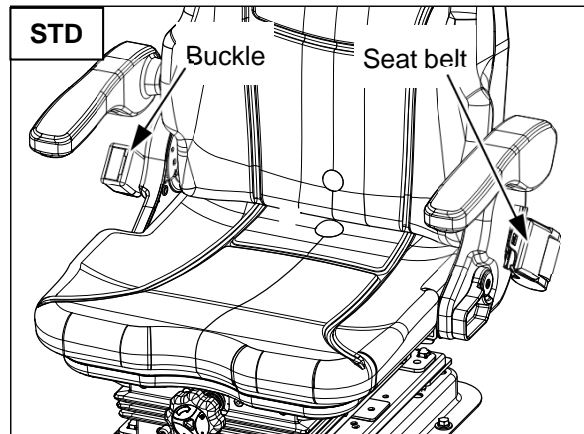
- Always wear the seat belt before operating the tractor and adjust the belt to fit the operator.
  1. Insert the seat belt end into the buckle until a “click” indicates it is properly engaged.
  2. To remove the seat belt from the buckle, press the red release button on the buckle.
- Check the seat belt regularly. If damaged or frayed, replace it with a new one.



 Warning	<ul style="list-style-type: none"><li>▶ If not wearing the seat belt, it may cause serious injury in case of an accident.<ul style="list-style-type: none"><li>- During operation, it must be required to wear the seat belt with a cab or roll-bar installed.</li><li>- After wearing the seat belt, adjust it to fit your body.</li></ul></li><li>▶ If the roll-bar is folded down or removed, do not wear the seat belt.</li></ul>
	

#### (4) Tilting steering wheel

- Press the steering tilt pedal down to release the steering wheel and tilt the steering wheel to the desired position.
- Release the tilt pedal to lock the steering wheel in place, and make sure to check the steering column locked in place.
- You must adjust the steering column only when the tractor has stopped completely.

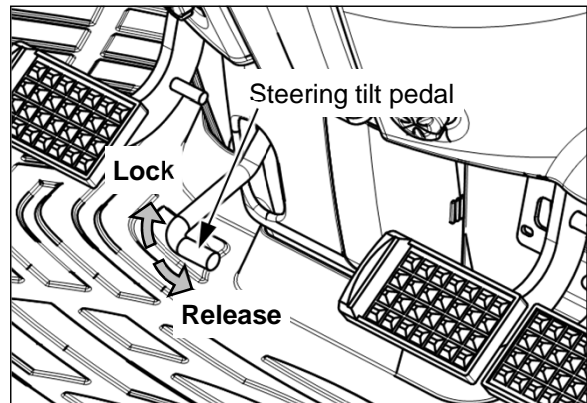

Caution

► DO NOT adjust steering wheel while driving. It may cause a serious accident.

#### (5) Ventilation (Cabin only)

- Air can be taken from outside or inside of the cabin by adjusting the ventilation lever.
  - **External circulation** : Air comes from outside via cabin air filters.
  - **Internal circulation** : Air can be re-circulated inside the cabin.
- To increase the air pressure inside the cabin, move the ventilation lever to external circulation and turn the blower control switch clockwise fully.

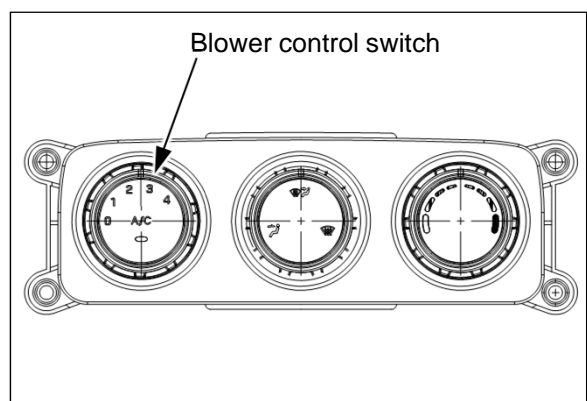
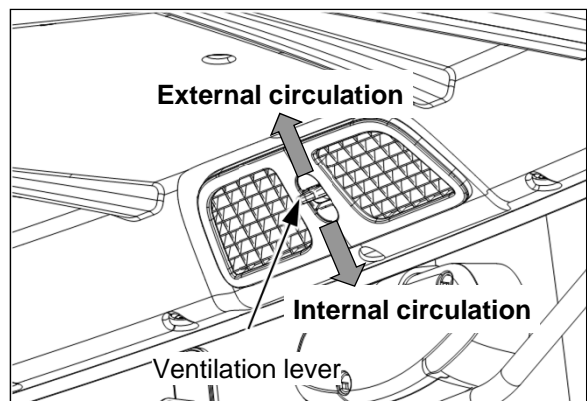

Warning

► DO NOT ventilate the cabin in pesticides or other hazardous spraying area.

## (6) Exiting the tractor

### ① Door (Left / Right)

- Whenever possible, use the left-hand side door for exiting the cabin.
- To open the left/right cabin door, push the door release lever outside, and use the grab handle to push the door outside.
- Do not jump up/down for your safety. *Jumping on/off the tractor could cause an injury. Always face the tractor, use the handrails and steps, and get on/off slowly. Maintain a three-point contact to avoid falling: both hands on the handrails and one foot on the step, or one hand on the handrail and both feet on the steps.*
- Remove the starter key and lock the cabin doors before leaving the tractor.

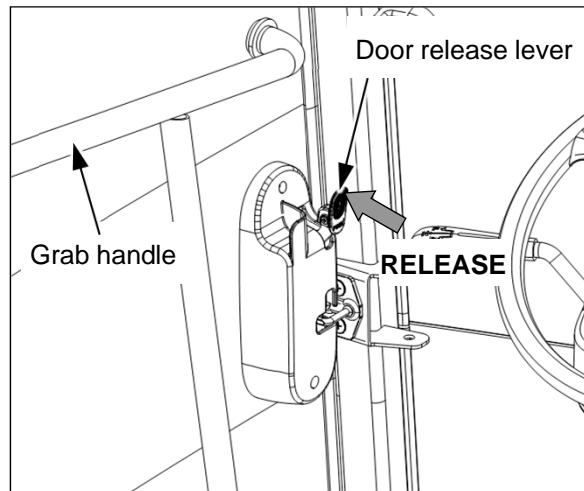

Caution

► Do not grasp the transmission gear levers when entering /exiting the cabin .

### ② Rear Window (for emergency)

- To open the rear window, turn the rear window grip clockwise with pulling the grip.
- Push the grip outside slightly.
- This rear window can be used for emergency exit or ventilation.

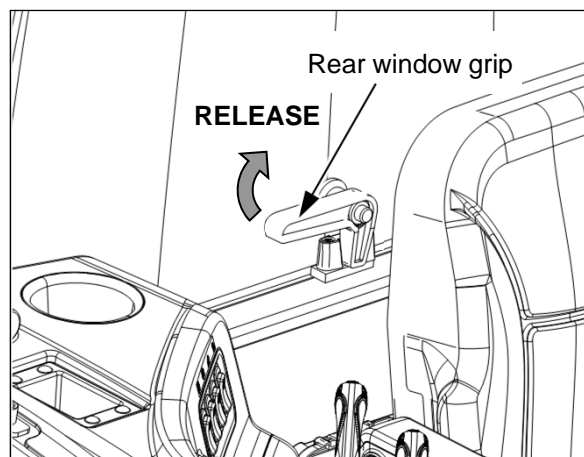

## 2-2. Safety device

### (1) Hood (Bonnet)

- Hood is a protection device to prevent an unintended access to the rotating parts around engine; cooling fan, fan belt and rotating shaft and pulley.
- Do not remove and modify the hood.

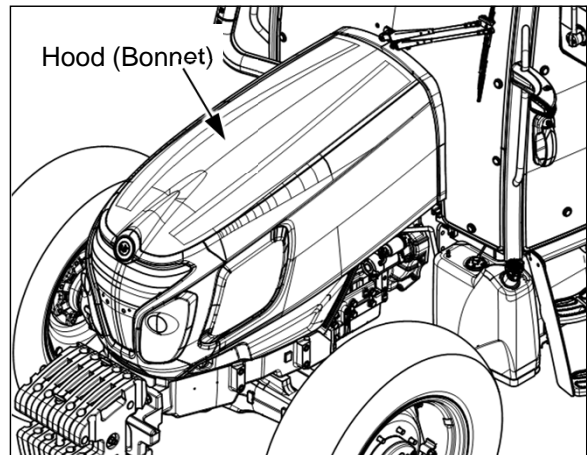

### (2) Fender

- Fender is a protection device to prevent an unintended access to the rear tires and to prevent mud from irrupting to the driver.
- Do not remove and modify the fender.

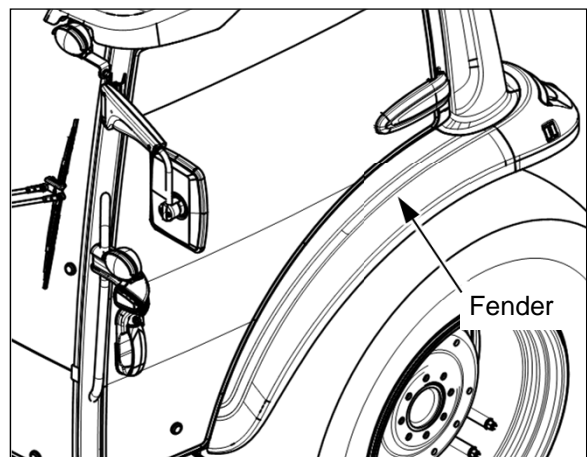

### (3) PTO safety cover and protection cap

- PTO safety cover is a protection device to prevent an unintended access to the PTO shaft and to prevent an accident causing by the rotating drive shaft.
- Do not remove the PTO safety cover. If the PTO safety cover or protection cap is damaged or removed, replace it with a genuine part.
- Do not step on the PTO safety cover.
- After using the PTO shaft, apply grease and insert the PTO shaft protection cap.

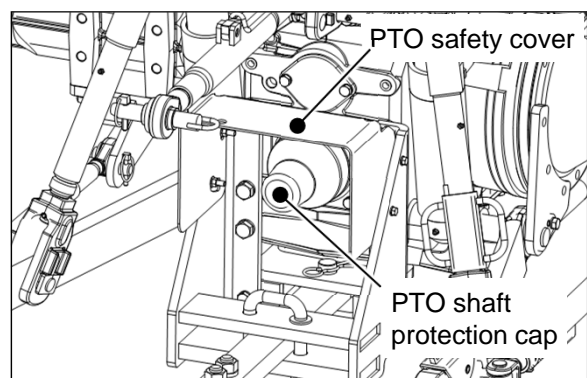

#### Warning







- ▶ If you contact the rotating shaft, it may cause a severe injury.
  - DO NOT try to touch the rotating shafts.
  - DO NOT remove the protection covers.
  - Avoid loose clothes that can easily be rolled up in the rotating shaft.

## (4) Roll-Over Protective Structure (ROPS) (optional)

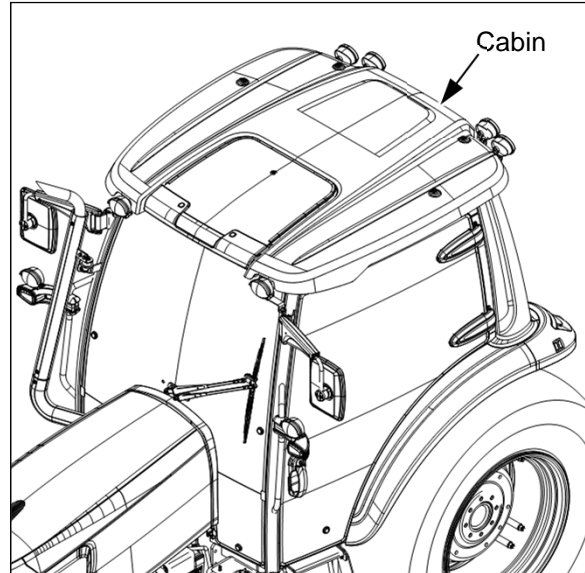
### ① Cabin

- This Roll-Over Protective Structure, Cabin is an integrated and certified structure for driver's safety. This structure will reduce the risk of serious injury or death when being over-turned.
- DO NOT remove, modify or repair the cabin arbitrary. Any damage of fire, corrosion, welding, bending, drilling, grinding and cutting of any part of the cabin, it can weaken the protective structure.
- If the cabin mounting bolts or other inter-connecting parts are loosened or removed for any reason, make sure that all the parts reinstalled correctly before operating the tractor.



 <b>Warning</b>	<p><b>Roll-over hazard!</b> Failure to comply could result in death or serious injury.</p>
 	<ul style="list-style-type: none"> <li>▶ Do not modify or remove the Roll-Over Protective Structure(ROPS) arbitrarily for safety. Unless the ROPS is installed correctly, it may cause a serious accident or death when being overturned.</li> <li>▶ Be sure to stand up the Roll-Over Protective Structure(ROPS) and check the bolts, pins and nuts correctly kept in place.</li> <li>▶ Always wear the seat belt when operating the vehicle in the cabin.</li> <li>▶ Do not connect chains or ropes to the ROPS for pulling purposes, as the vehicle could tip over.</li> <li>▶ When driving through door openings or under low overhead objects, make sure there is sufficient clearance for the ROPS.</li> <li>▶ Do not step on the fender for the maintenance of cabin roof.</li> </ul>





# 3. Instruments and Controls

## 3-1. Instrument panel and Front controls

Important to owner, read carefully

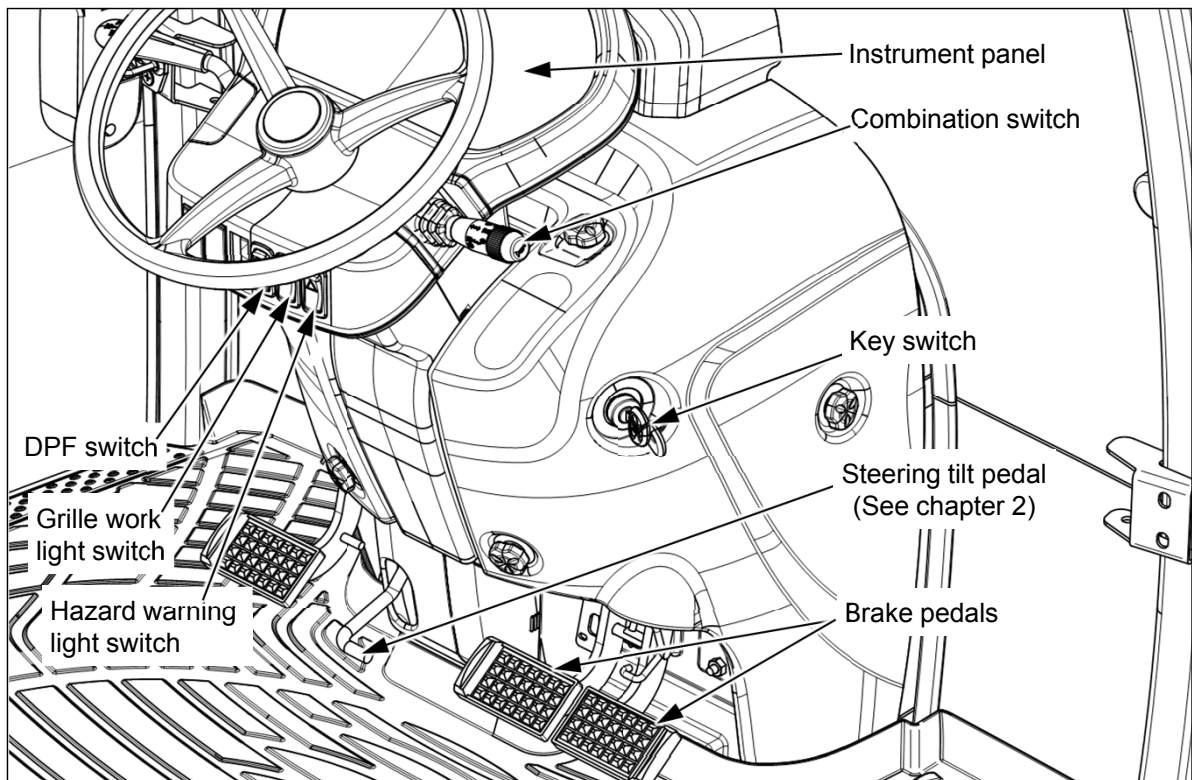
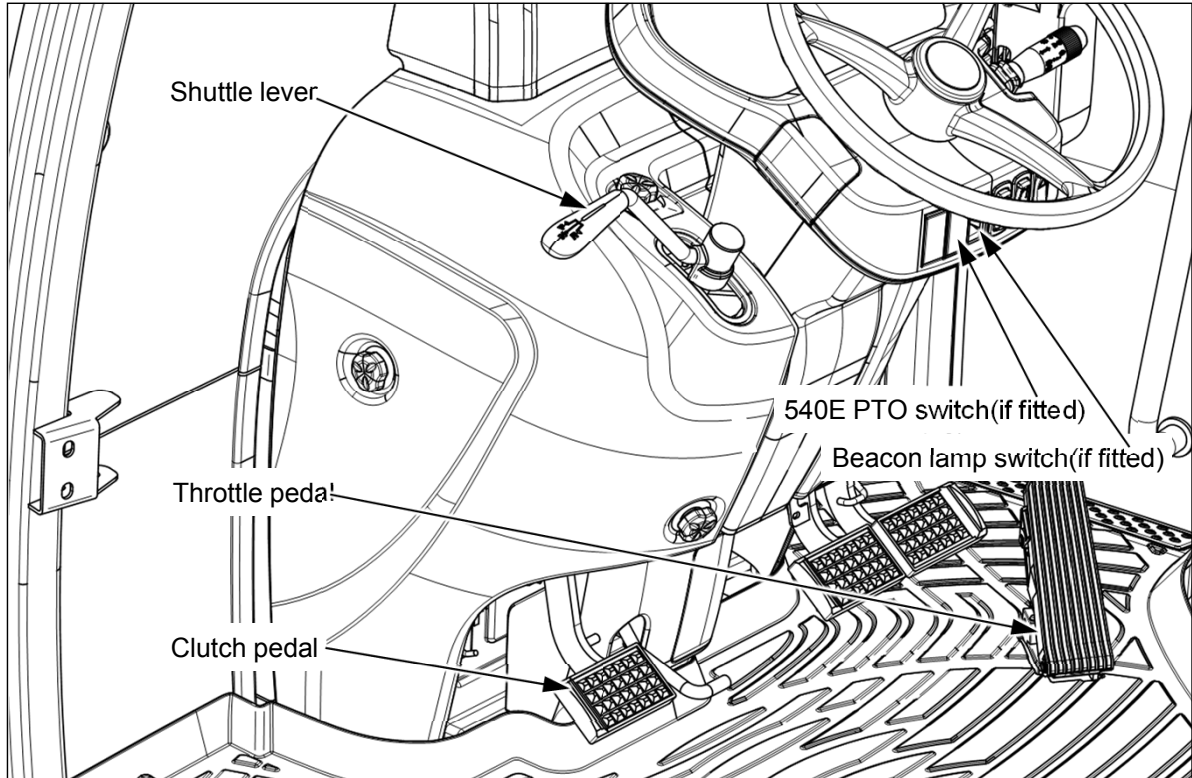

## (1) Instrument panel

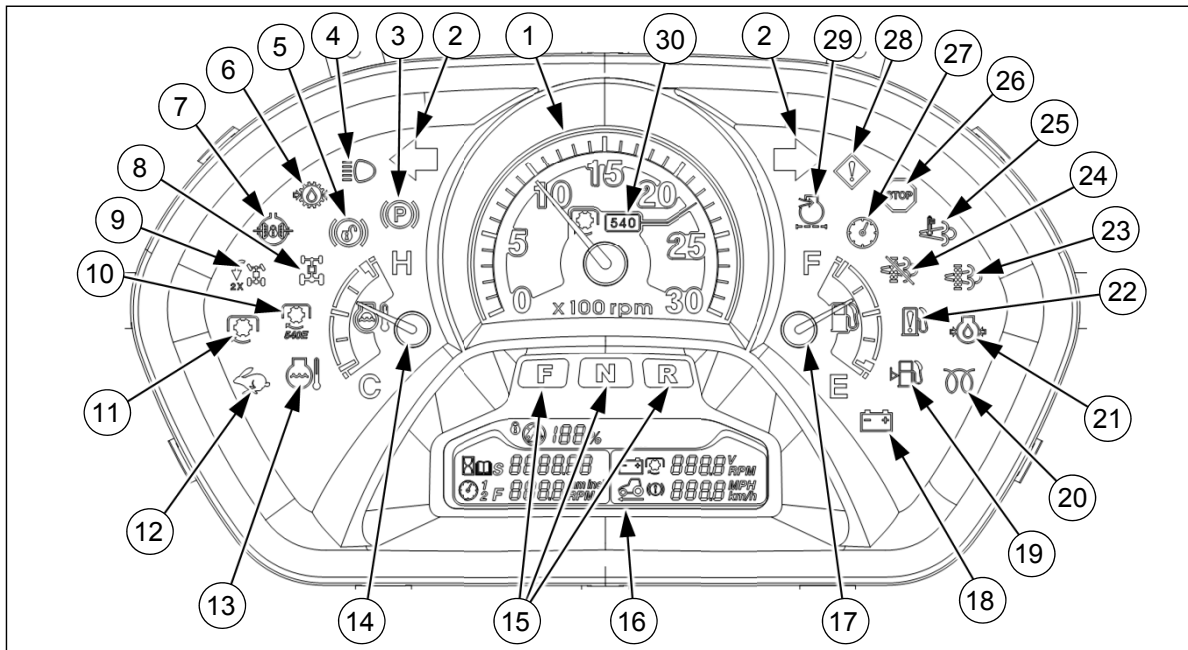

- |   |   |
|---|---|
| ① Tachometer                                    | ⑩ 540E PTO operation indicator(optional)      |
| ② Turn signal indicator (LH/RH)                 | ⑪ PTO operation indicator                     |
| ③ Parking brake indicator                       | ⑫ High speed indicator (Not used)             |
| ④ High beam indicator                           | ⑬ Coolant over-heat warning indicator         |
| ⑤ Brake pedals not latched indicator (optional) | ⑭ Engine coolant temperature gauge            |
| ⑥ Hydraulic oil filter pressure indicator       | ⑮ Forward/Neutral/Reverse indicator(optional) |
| ⑦ Differential lock indicator                   | ⑯ LCD display panel                           |
| ⑧ 4WD indicator                                 | ⑰ Fuel level gauge                            |
| ⑨ Quick turn indicator(optional)                | ⑱ Battery charging indicator                  |
| ⑫ High speed indicator (Not used)               | ⑲ Low fuel level indicator                    |
| ⑬ Coolant over-heat warning indicator           | ⑳ Cold start aid indicator                    |
| ⑭ Engine coolant temperature gauge              | ㉑ Engine oil pressure indicator               |
| ⑮ Forward/Neutral/Reverse indicator(optional)   | ㉒ Fuel filter warning indicator               |
| ⑯ LCD display panel                             | ㉓ DPF regeneration indicator                  |
| ⑰ Fuel level gauge                              | ㉔ DPF regeneration inhibited indicator        |
| ⑱ Battery charging indicator                    | ㉕ Exhaust gas temperature high indicator      |
| ⑲ Low fuel level indicator                      | ㉖ Stop lamp indicator                         |
| ⑳ Cold start aid indicator                      | ㉗ Engine Speed Cruise control indicator       |
| ㉑ Engine oil pressure indicator                 | ㉘ Vehicle control error warning indicator     |
| ㉒ Fuel filter warning indicator                 | ㉙ Air cleaner service indicator               |
| ㉓ DPF regeneration indicator                    | ㉚ PTO speed indicator                         |
| ㉔ DPF regeneration inhibited indicator          |   |
| ㉕ Exhaust gas temperature high indicator        |   |
| ㉖ Stop lamp indicator                           |   |
| ㉗ Engine Speed Cruise control indicator         |   |
| ㉘ Vehicle control error warning indicator       |   |
| ㉙ Air cleaner service indicator                 |   |
| ㉚ PTO speed indicator                           |   |

① Tachometer

- The tachometer shows the engine revolutions per minute ("30" means 3000rpm). The display will return to zero when the engine is not running

② Turn signal indicator (Left / Right)

- When turning the turn signal light switch to the left/right direction, the front/rear turn signal lights and this indicator will blink simultaneously. The key switch has to be in the "ON" or "Start" positions. Before turning the vehicle while driving on the road, turn on the turn signal lights.
- When turning on the hazard warning light switch, all the turn signal light will blink simultaneously regardless of the key switch position. Use the hazard warning light switch in an emergency state according to your local traffic regulation.

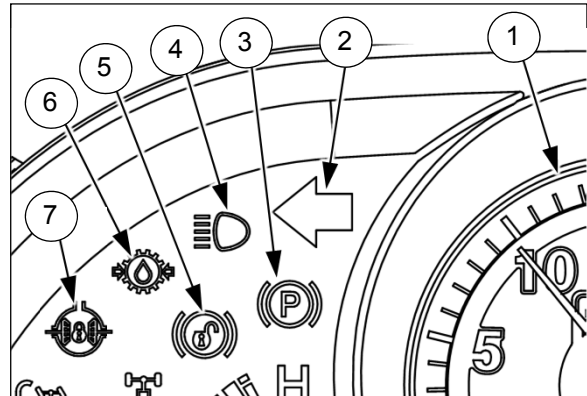

③ Parking brake indicator

- This indicator will be turned on when applying the parking brake. Do not drive the vehicle with the parking brake applied.
- If shifting the F/R shuttle lever forward or reverse when the parking brake is engaged, this indicator will blink with alarming buzzer.

④ High beam indicator

- When turning on the high beam of the headlamps, this indicator will be turned on simultaneously. Do not turn on the high beam when a vehicle comes in the opposite lane.

⑤ Brake pedals not latched indicator (Not used)

- When the brake pedals are not connected with brake pedal latch, the LH/RH pedal is can be operated separately, and this indicator will be turned on. (optional)

⑥ Hydraulic oil filter pressure indicator

- If the pressure differential of the hydraulic oil filter is increased over the designated level, this indicator will be turned on. Replace the oil filter with a new one.
- It may be turned on in cold winter. Warm up the transmission oil and recheck the indicator.

⑦ Differential lock indicator

- This indicator will be turned on when activating the differential lock switch with the key switch placed "ON" position. .

8 4WD indicator

- When pressing the 4WD switch to “4WD” position, this indicator will be turned on.
- When pressing down the brake pedals, the 4WD will be engaged automatically to brake the front wheels, and this indicator will be turned on.

9 Quick turn indicator (optional)

- When pressing the quick turn switch to “ON” position while the key switch is “ON” position, this indicator will be turned on.

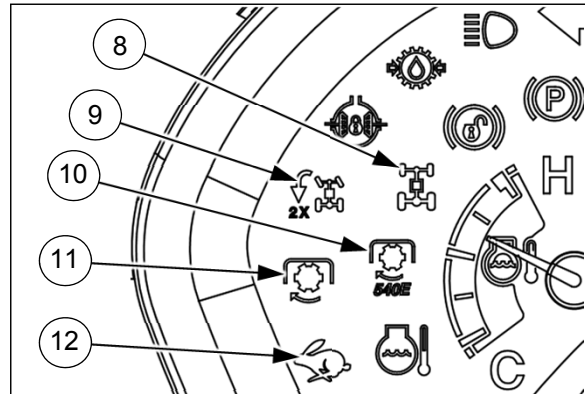

10 540E PTO operation indicator (optional)

- When the PTO gear lever is 750/540E rpm, and PTO switch and 540E PTO switch is “ON” position, this indicator will be turned on, and the engine maximum speed will be restricted in this mode.

11 PTO operation indicator

- When the key switch is “ON” and PTO mode switch is “MANUAL” and PTO switch is “ON”, this indicator will be turned on.
- If the PTO mode switch is “AUTO”, rear PTO and this indicator will be turned off to protect the PTO drive shaft when the clutch pedal is depressed or the implement is lifted up over the specified limit. (For further information, See page 3-31)

12 High speed indicator (Not used)

- This indicator is not used in this model.

13 Coolant over-heat warning indicator

- If the engine coolant temperature goes over the critical level, this indicator will be turned on. Stop and cool down the engine coolant.
- If not cleared, contact your authorized local dealer for check.

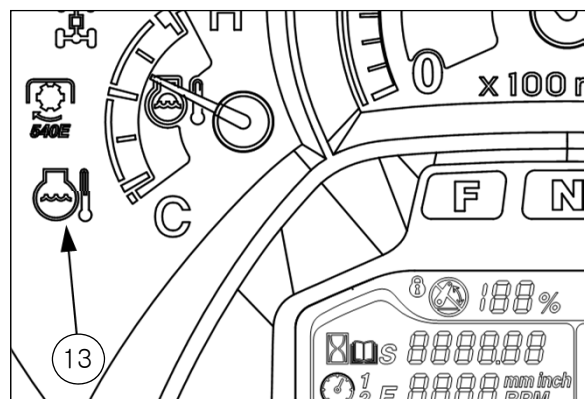

14 Engine coolant temperature gauge

- This gauge indicates the engine coolant temperature during operation. It activates when the operator turns the key switch to the ON position. The gauge will register cold with the key switch in the OFF position.
- The closer the needle approaches “H” mark, the higher the temperature of engine coolant is. If the needle moves to red portion of the gauge, this indicates an overheated condition. Stop the engine immediately and check the problem.
- Coolant is very hot. When checking the coolant, *comply with the instructions of the chapter 5-12-(1), “Replacement of Engine coolant” in this manual.*

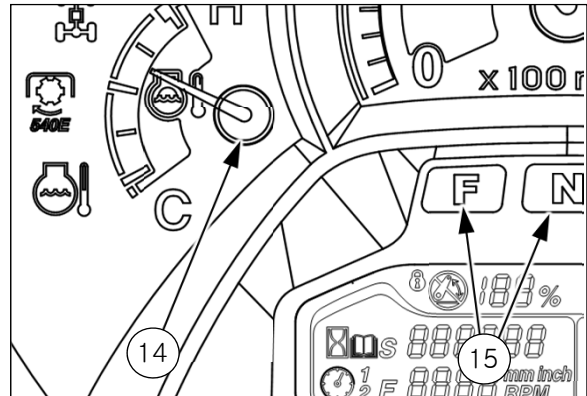

15 Forward/Neutral/Reverse indicator(optional)

- These indicators will be turned on/off when operating the power shuttle lever to FORWARD/NEUTRAL/REVERSE position on the power shuttle models.

16 LCD display panel

**a) Hour meter & Engine diagnosis error code**

- If an error does not exist on the engine control, in normal operating condition, accumulated operation hours will be displayed
- If the display shows “0019.1”, it means the tractor has been operated for 19.1 hours so far, (19 hours and 6 minutes)
- If any of errors related to the engine control occur, the engine diagnosis error codes and hour meter will be displayed by turns with the vehicle control error warning light (28). At this time, after escaping from the emergency area, contact your authorized local dealer for check.

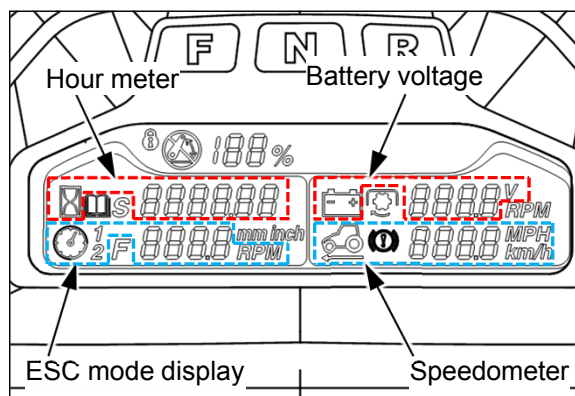

**b) Battery voltage**

- Available current battery voltage is displayed.

**c) Engine Speed Cruise control(ESC) and FMI code**

- The RPM stored on ECU for Engine Speed Cruise control(ESC) is displayed in normal status.
- If any of errors related to the engine control occur, the FMI code to be able to know the error type or pattern will be displayed by turns additionally with the engine diagnosis error codes (9).

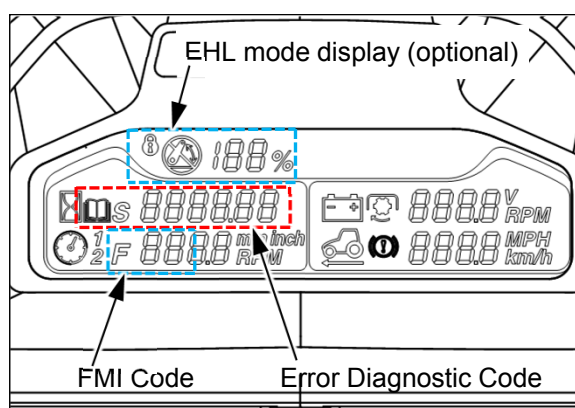

**d) EHL mode display (optional)**

- For only Electro-Hydraulic Lift (EHL) models, this display shows the current lifting position per maximum upper limit in percent ratio.

**e) Trailer brake pressure warning indicator**

- If the trailer brake air pressure is lower than the designate level, this display will be turned on with the red vehicle control error warning indicator (28).

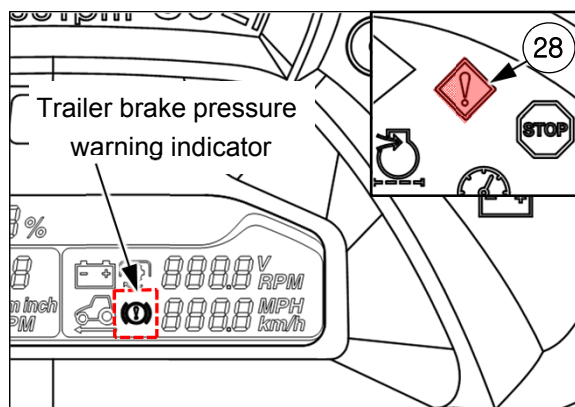

① **Tire rolling circumference and Vehicle speed**

- The rolling circumference of the rear tire and the vehicle speed are displayed in mm/inch and km/h/mpH.
- **Changing Unit(km/h ↔ mph, mm ↔ inch):** Press the upper side of the ESC main switch shortly(within one second). The unit change is only available before editing the tire rolling circumference.
- **Entering edit mode:** Turn key switch to “ON” position with pressing the upper side of the ESC main switch. At this time, the tire rolling circumference, “CAL”, and vehicle speed will be displayed.
- **Editing tire rolling circumference:** In edit mode, the first digit will blink at first. If pressing the upper side of the ESC speed up/down switch, the next digit will blink. If pressing the lower side of the switch, the number is changed from “9” to “0” each time you press.

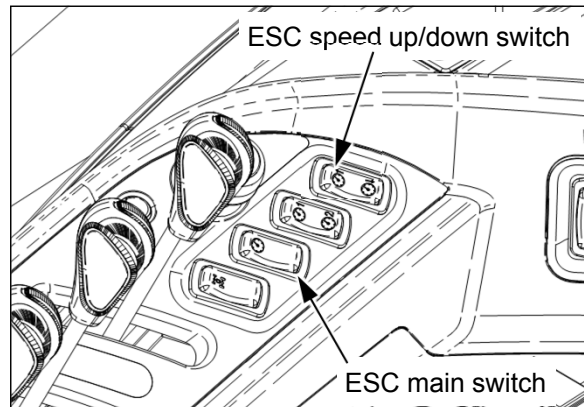

①⑦ Fuel level gauge

- This gauge shows the fuel level in the fuel tank. If the needle indicates “E”, fill the fuel tank immediately with fuel.
- The gauge activates when the key switch is in the ON position. It will register “empty” with the key switch in the OFF position.

①⑧ Battery charging indicator

- This indicator will be turned on when turning the key switch to “ON” position, and it will be turned off after the engine starts.
- If this bulb becomes lit during operation, it indicates that the charging system is not operating normally. As the battery can be fully discharged under these conditions, contact your authorized local dealer for checking the electrical charging system.

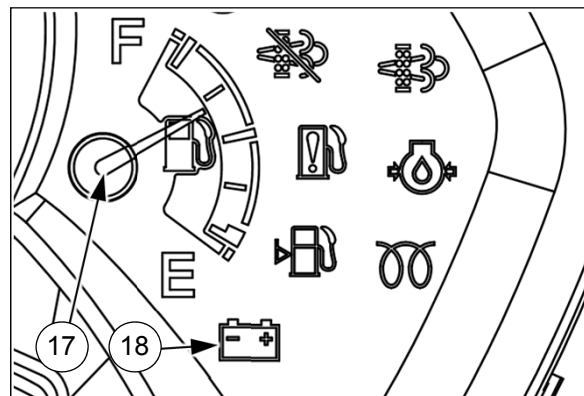

19 Low fuel level warning indicator

- When the fuel level in the fuel tank becomes below minimum level, this indicator will be turned on. If this indicator turns on, fill the fuel tank immediately with fuel. When working on the uphill/downhill, the fuel can be exhausted before this indicator is turned on. Add fuel in advance.

20 Cold start aid indicator

- When the cold start aid device is working, this indicator will be turned on, and it will be turned off about some seconds later. It may vary depending on the ambient temperature. After this indicator is turned off, start the engine.

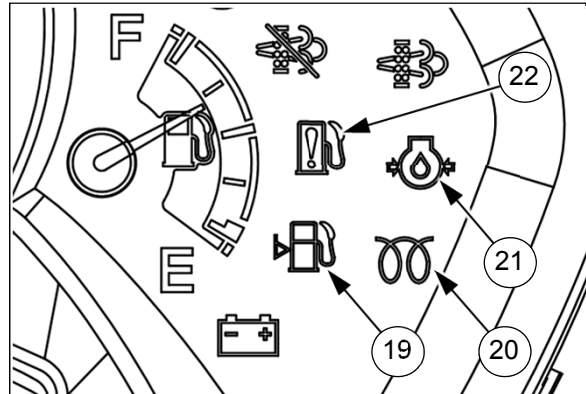

21 Engine oil pressure indicator

- This indicator will be turned on when turning the key switch to "ON" position and it will be turned off after starting engine.
- The light indicates oil pressure only and goes out when sufficient oil pressure is present at the oil sender.
- If this indicator is turned on during operation, stop the engine and check the engine oil level. If the engine oil level is normal, contact your authorized local dealer for check.

22 Fuel filter warning indicator

- When there is a restriction or excess water in the fuel filter, this indicator will be turned on. If this indicator turns on, remove water in the fuel filter. (See chapter 5-5-(1) in this manual.)

23 DPF Regeneration indicator

- When the regeneration process in the DPF is working, this indicator will be turned on with continuous light. It is not a failure but normal operation.
- **If this indicator is blinking, it means that the soot is over accumulated in the DPF. Comply with the instructions of the chapter 3-1-(10), "DPF switch" in this manual.**
- For further information about this indicator, see page 3-20 in this manual.

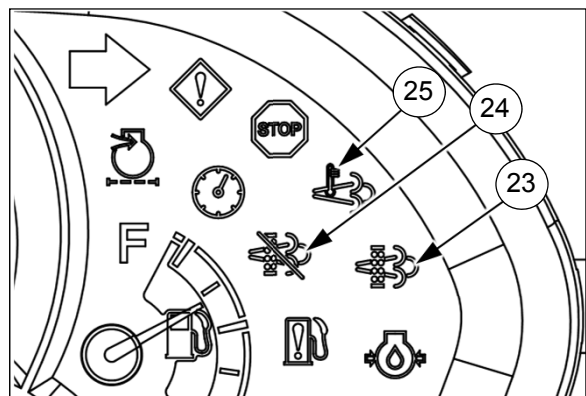



24 DPF regeneration inhibited indicator

- When the DPF switch is pressed to **Inhibited regeneration mode**, this indicator will be turned on and the regeneration of the DPF will be stopped.

25 Exhaust gas temperature high indicator

- When the regeneration process in the DPF is working and the DPF temperature is over the designated temperature, this indicator will be turned on with continuous light.

26 Stop lamp indicator

- If there is a significant error on the vehicle control, This indicator will be turned on. Contact your authorized local dealer for check.

27 Engine Speed Cruise control(ESC) indicator

- This indicator is turned on when operating the ESC main switch to “ON” position and the Engine Speed Cruise control(ESC) is ready.

28 Vehicle control error warning indicator

- If there is a significant error on the vehicle control, This indicator will be turned on. Contact your authorized local dealer for check.

29 Air cleaner service indicator

- If the air cleaner element is clogged, and the differential pressure is increased, this indicator will be turned on. After stopping the engine, clean or replace the filter element with a new one.

30 PTO speed indicator

- It determined by the position of the needle on the tachometer. The tachometer is marked to indicate 540 RPM of rear PTO.
- If the tachometer registers above the 540 RPM mark for rear PTO operation, this indicates a dangerous over-speed condition. Reduce the engine speed immediately.

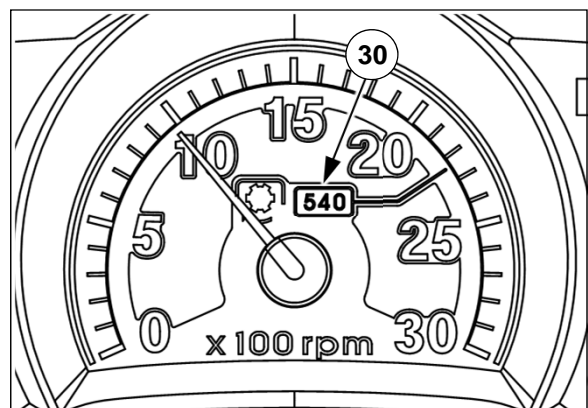
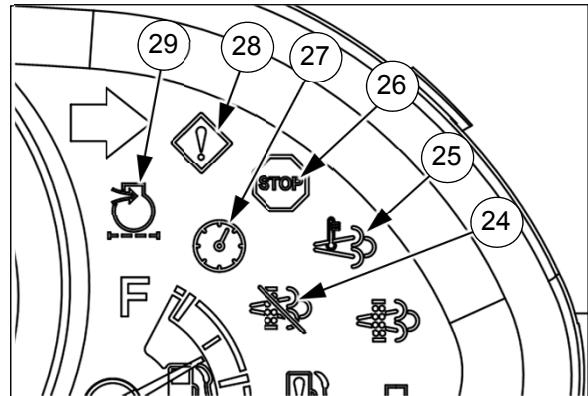

## (2) Key switch

- **OFF** - power off (engine stop)
- **ON** - power on & automatic glow
- **Start** - engine start
- As soon as the engine starts, turn the ignition key to ON position immediately. If not, it may cause damage to the starter motor.

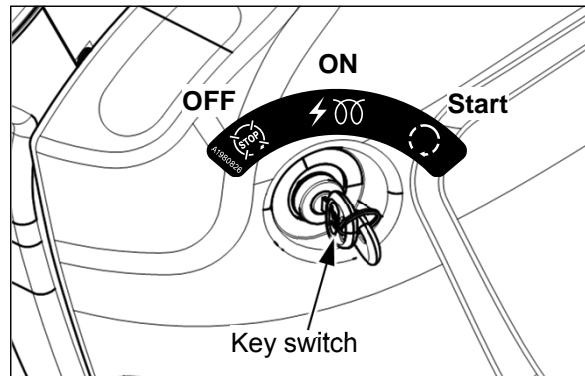

 Caution	<ul style="list-style-type: none"><li>▶ Because a safety switch for start-up has to be engaged, put PTO switch to “OFF” position, depress the clutch pedal fully, and place the F/R shuttle lever in neutral position, and then turn the key switch to “Start” position. See <i>chapter 4-2-(1), “Engine Start”</i> in this manual.</li><li>▶ If the tractor is not in use, the ignition key should be removed.</li></ul>
---	---

## (3) Throttle pedal

- This pedal is used when driving on the road.
- When using the throttle pedal, the throttle lever must be placed in “Low speed” position.
- When pressing brake pedals with pressing the throttle pedal first, the engine speed will be changed to the low idle speed.
- When pressing the throttle pedal with pressing brake pedals first, the engine speed will be controlled by the throttle pedal according to its stroke.
- There is a sensitive electric sensor on the throttle pedal. Do not remove or modify the throttle pedal arbitrarily.

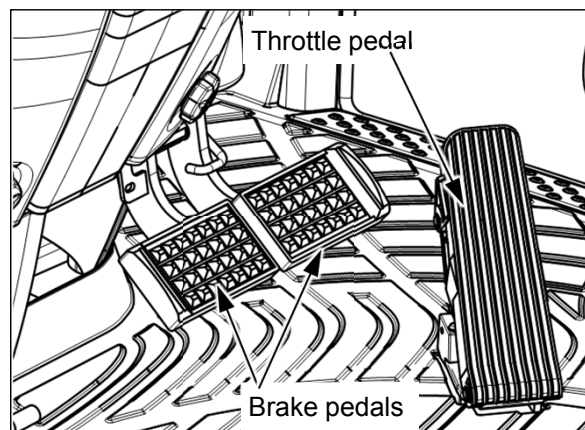

## (4) Clutch pedal

- This is used to engage or disengage the main transmission clutch for starting engine and shifting transmission gear.
- Depress the clutch pedal quickly and fully and release it slowly.
- When depressing the clutch pedal, If PTO mode switch is placed on;
  - **AUTO**: the PTO shaft will be stopped.
  - **MANUAL**: the PTO shaft will **NOT** be stopped,

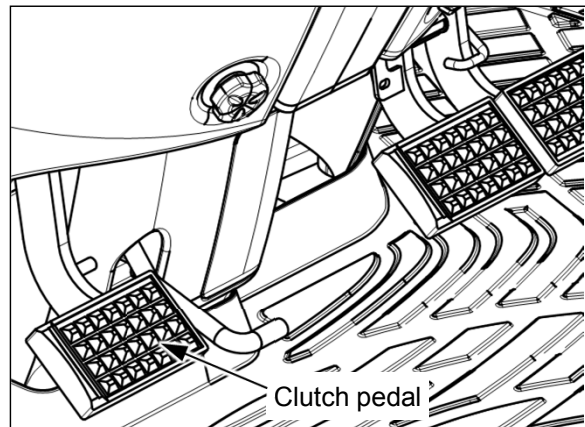

 Caution	<ul style="list-style-type: none"><li>▶ DO NOT ride your foot on the clutch pedal while driving the tractor.</li><li>▶ As a start safety switch is installed for the operator's safety, depress the clutch pedal fully for starting engine.</li></ul>
---	---

## (5) Shuttle lever (Synchro-shuttle)

- It is used to select the Forward / Reverse. Before shifting this lever, depress the clutch pedal fully.
- **Forward**: Push the lever forward.  
**Reverse**: Pull the lever backward.
- Before reversing the tractor, lower the engine speed and check the safety conditions behind the tractor.
- If shifting F/R shuttle lever forward or reverse when the parking brake is engaged, the parking brake indicator will blink with alarming buzzer. Before shifting the shuttle lever, be sure to release the parking lever.
- Before starting the engine, be sure to place the shuttle lever in neutral position.

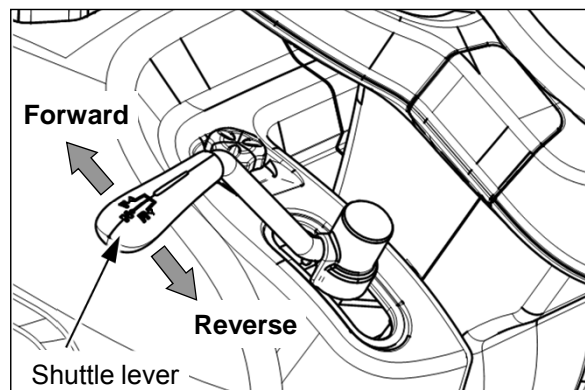

 Caution	<ul style="list-style-type: none"><li>▶ The synchro-shuttle shift lever allows any forward range or reverse to be shifted while the tractor is moving slowly. However, the clutch must be disengaged and the engaged by means of clutch pedal. Make sure to depress clutch pedal fully and release it gradually to take up load smoothly, but sudden gear shifting may cause transmission damage. It is recommended to stop the tractor before operating the shuttle lever.</li></ul>
---	---

## (6) Brake pedals

- When stopping the tractor, press both brake pedals together with depressing clutch pedal.
- If the brake pedals are not locked with pedal latch, left or right brake pedal can be operated independently. This one-brake pedal operation is useful to reduce the turning radius in field ground.
- DO NOT press the one-brake pedal while the differential lock is engaged. It may cause damage or failure of the rear axle.
- When brake pedals are pressed, 4WD will be engaged automatically to brake the front wheels.
- When pressing brake pedals with pressing the throttle pedal first, the engine speed will be changed to low idle.
- The brake lights<sup>③</sup> will illuminate when the brake pedal is depressed and the key switch is "ON" position.

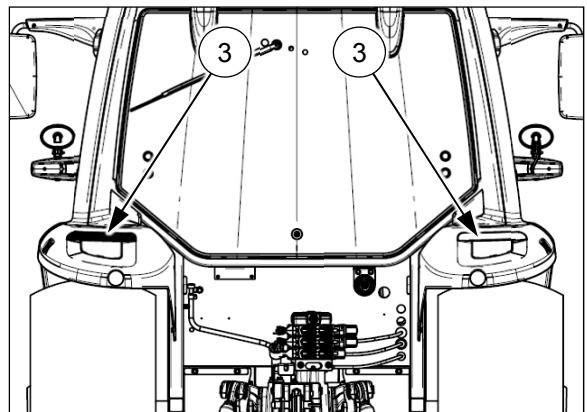
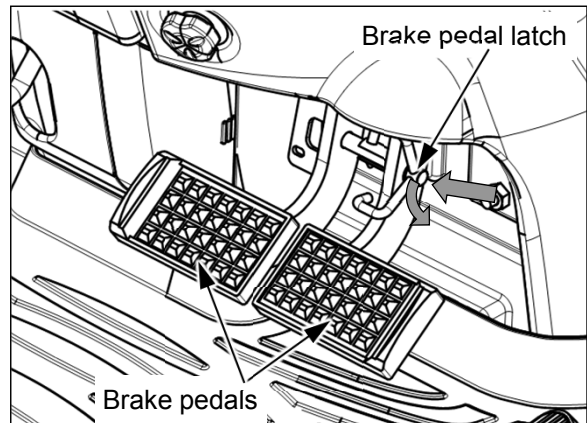

- ▶ Must lock the brake pedals with the pedal latch while driving.
  - If pressing one-side brake pedal while driving, the tractor may turnover.
- ▶ DO NOT ride your foot on the brake pedals while driving to prevent the brake disks or other brake system components from being damaged.

## (7) Combination light switch

### 1 Turning ON/OFF the lights

- Combination light switch is used to turn on/off the following lights.

① Instrument panel lights, ② Side lights.

③ Tail lights, ④ Headlights.

- To turn on/off the lights, turn the switch to the position where the related symbol is marked.

○ - Instrument and all the lights are OFF.

≡D≡ - Instrument, side lights and tail lights are turned on.

≡D - Instrument panel, side lights, tail lights and headlights(Low beam) are turned on.

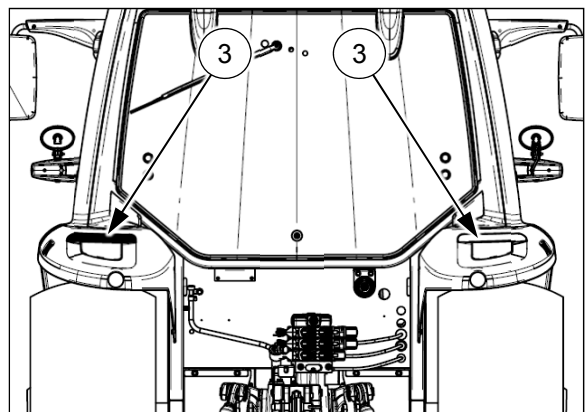
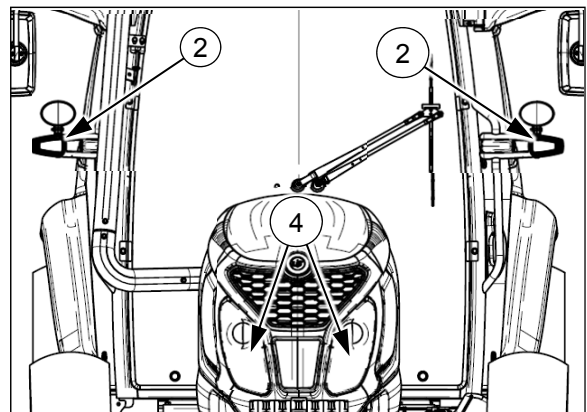
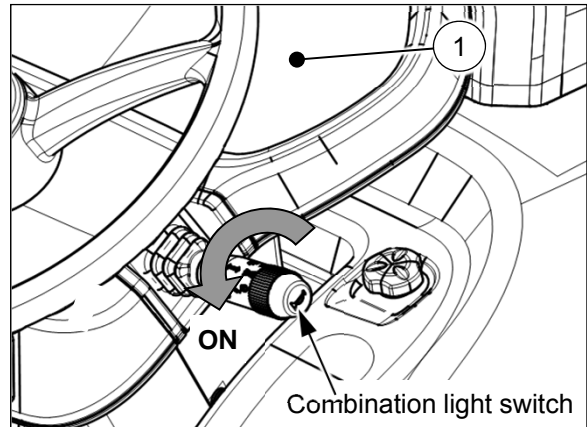

Caution

► When passing with other vehicles in the opposite lane at night, turn the headlights to low beam not to disturb oncoming cars.

## 2 Turning ON/OFF High beam

- When pushing the switch downward from neutral position, the switch will be locked and the high beam of the headlights ① will be turned on.
- To turn off the high beam, return the switch to neutral position.

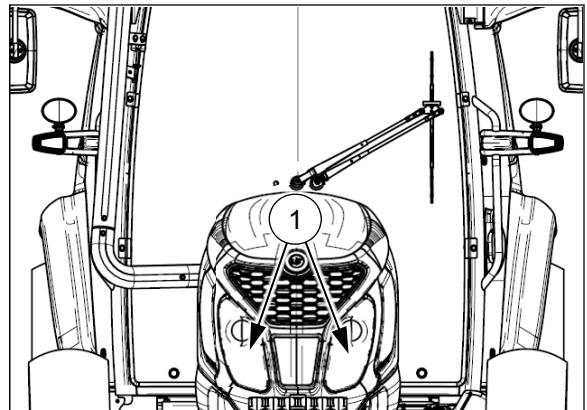
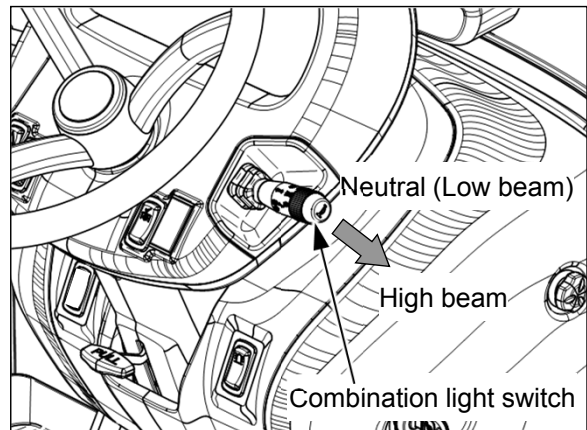

- ▶ When passing with other vehicles in the opposite lane at night, turn the headlights to low beam not to disturb oncoming cars.

### 3 Horn operation

- To sound off the horn, press the switch end to the inside.
- If releasing the switch, it will return to the original position and the operation of the horn will be stopped.

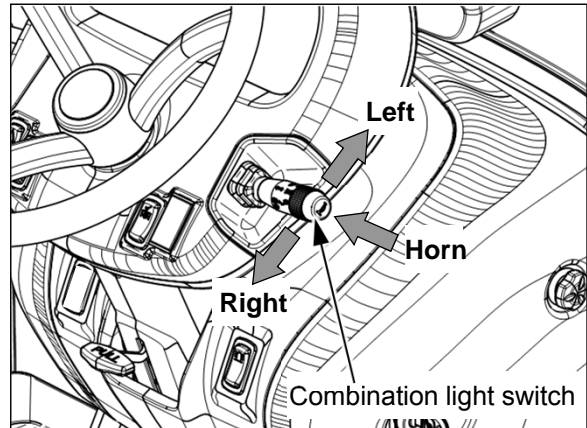

### 4 Operating turn signal lights

- This switch is used to give information to other vehicles when turning to the left or right.
- If shifting the switch to the right-hand direction, the right turn signal lights② and indicator are blink.
  - If shifting the switch to the left-hand direction, the left turn signal lights③ and indicator are blink.
- If the hazard warning lights are operated at the same time when the turn signal is activated, the hazard warning light for the opposite side of turning direction will stop flashing and illuminate continuously.

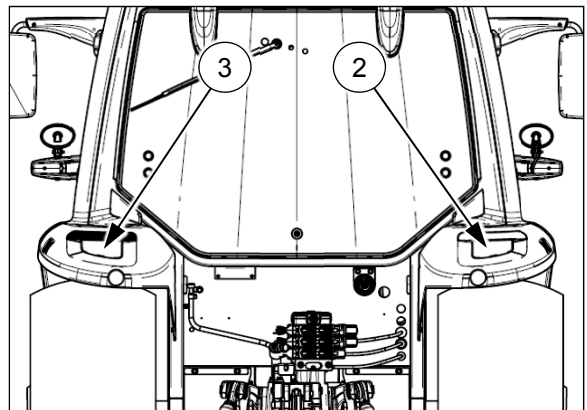
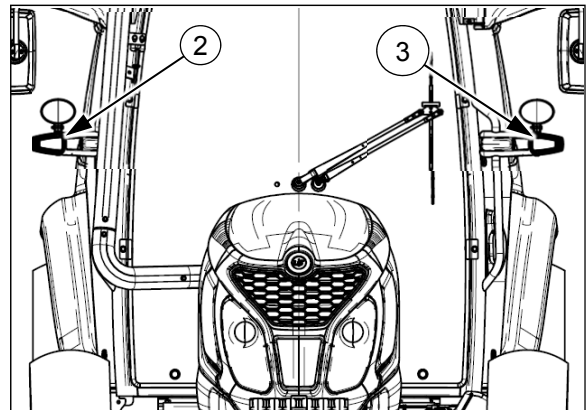

Notice	▶ When driving on the road, operate the turn signal lights to inform other vehicles before changing your direction.
--------	---

## (8) Hazard warning light switch

- This is used to give information to other vehicles in an emergency status.
- If you press the triangle switch (symbol part), all the turn signal lights<sup>②</sup>,<sup>③</sup> and indicators will blink.
- Use this hazard warning light switch in emergency situations according to your local traffic regulation.
- If the hazard warning lights are operated at the same time when the turn signal is activated, the hazard warning light for the opposite side of turning direction will stop flashing and illuminate continuously.

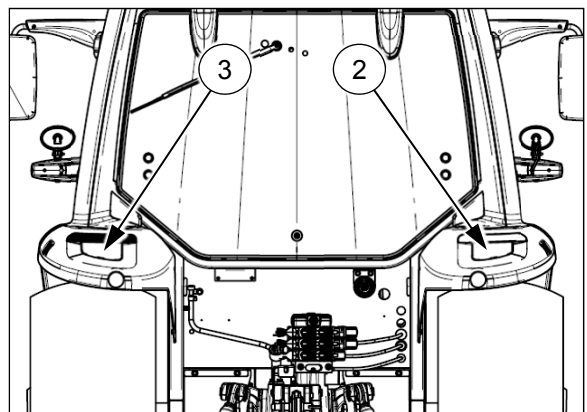
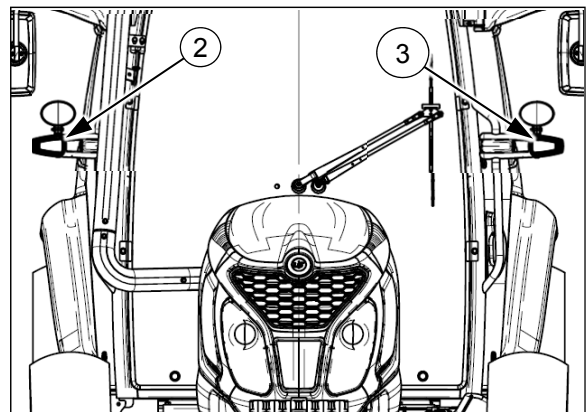
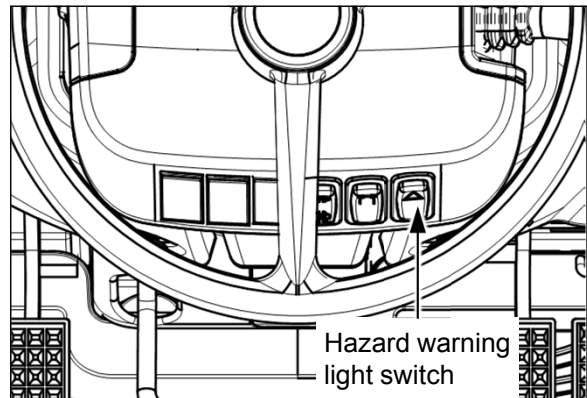

 <b>Caution</b>	▶ If using the hazard warning lights for a long time while the engine is stopped, the battery can be discharged due to high electrical power consumption.
--	---

<b>Notice</b>	▶ The hazard warning lights can be turned on regardless of the key switch position.
---------------	---



## (9) Grille work light switch

- This is used to turn on/off the griller work lights of the front grille.
- **ON** - Press the upper side(symbol part) of the switch.
- **OFF** - Press the lower side of the switch.

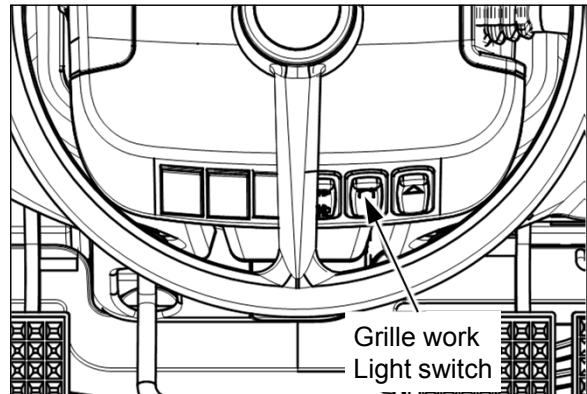

 Caution	<p>▶ When driving on the road at night, do not let the work lights stay turned on. It may cause a disturbance to the driver of the oncoming car.</p>
---	--

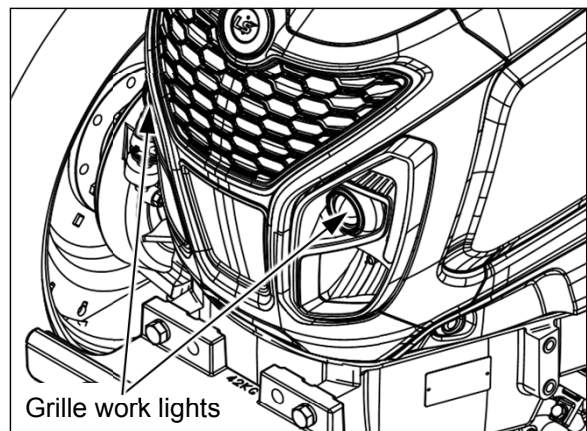

## (10) DPF switch

- The regeneration process is the process of burning and cleaning the soot accumulated in the DPF while driving.
- This switch is used to select the **Regeneration mode** or **Inhibited regeneration mode**.

- **Regeneration mode:** If the soot is loaded over the designated level and the engine is warmed up enough, the DPF regeneration will be processed automatically by ECU. *For more information, see page 3-20, 21 in this manual.*

- **Inhibited regeneration mode:** The regeneration mode is disabled manually until operator inputs the signal for exiting this mode. *For more information, see page 3-22 in this manual.*

- And, this switch is used to process the regeneration manually. *For the detail operating methods, see page 3-21 in this manual.*

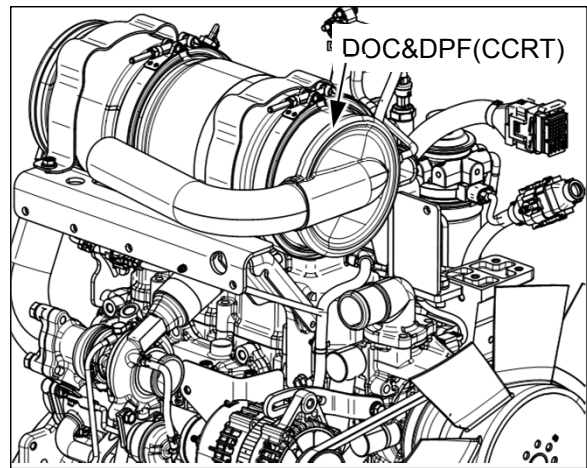
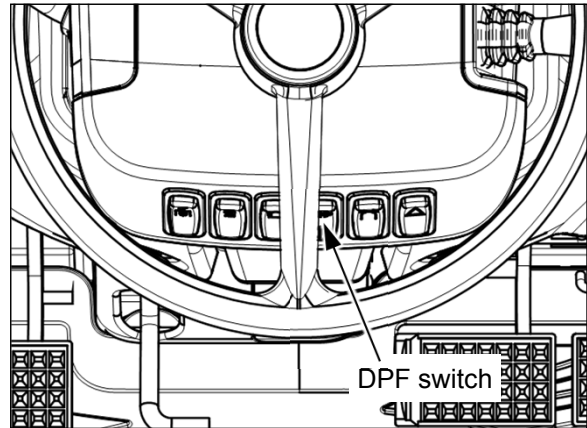

### ① Definitions of system components and operation

- The following terms will define the system components and functional descriptions.

System component	Description
Diesel Oxidation Catalyst (DOC)	This is a catalytic converter that designed specifically for diesel engines and equipment to reduce the emission element such as hydrocarbons(HC), carbon monoxide(CO) and unburned fuel.
Diesel Particulate Filter (DPF)	This is a filter and an after-processing component that captures soot in the engine exhaust gas, and to prevent the filter from clogging, the particulate matter will be automatically burned into CO <sub>2</sub> at a high temperature by regeneration process.

## ② DOC&DPF(CCRT)

- The Diesel Oxidation Catalyst (DOC) and the Diesel Particulate Filter (DPF) is to reduce engine exhaust hydrocarbons, carbon monoxide and other toxic gases. This system converts exhaust emissions to harmless carbon dioxide and water. The DPF also traps Particular Matter (PM)
- To meet the emission regulations, the CCRT(Catalyzed continuous regenerating trap) integrated with DOC and DPF combination is installed on your engine.
- It is very important to read this operator's manual and understand the safe operation of your tractor. If you have any questions in the operation of this emission system, please contact your authorized local dealer.

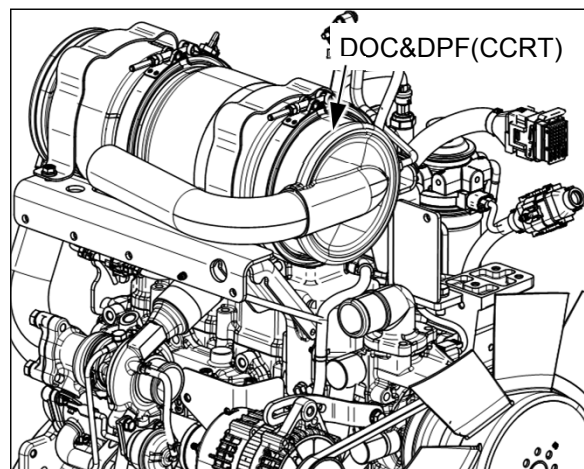

 <b>Caution</b>	<p>► <b>Burn hazard !</b></p> <p>During the Diesel Particulate Filter (DPF) regeneration process, the exhaust stack and fixed hood area becomes extremely hot. Allow area to cool before servicing or working near the exhaust system components.</p> <p>Failure to comply could result in minor or moderate injury.</p>
--	--

 <b>Warning</b>	<p>► <b>Fire hazard!</b></p> <p>During the Diesel Particulate Filter (DPF) regeneration process, the exhaust stack and fixed hood area becomes extremely hot. Park the machine outside and away from combustible or highly flammable material.</p> <p>Failure to comply could result in death or serious injury.</p>
--	--

## ③ Fuel and engine lubrication oil specification

- Fuel specification  
Use only Ultra low sulfur diesel fuel (S15) in your tractor.

<b>NOTICE</b>	<p>► Use of diesel fuel other than Ultra low sulfur fuel may adversely affect the engine and the DPF performance.</p>
---------------	---





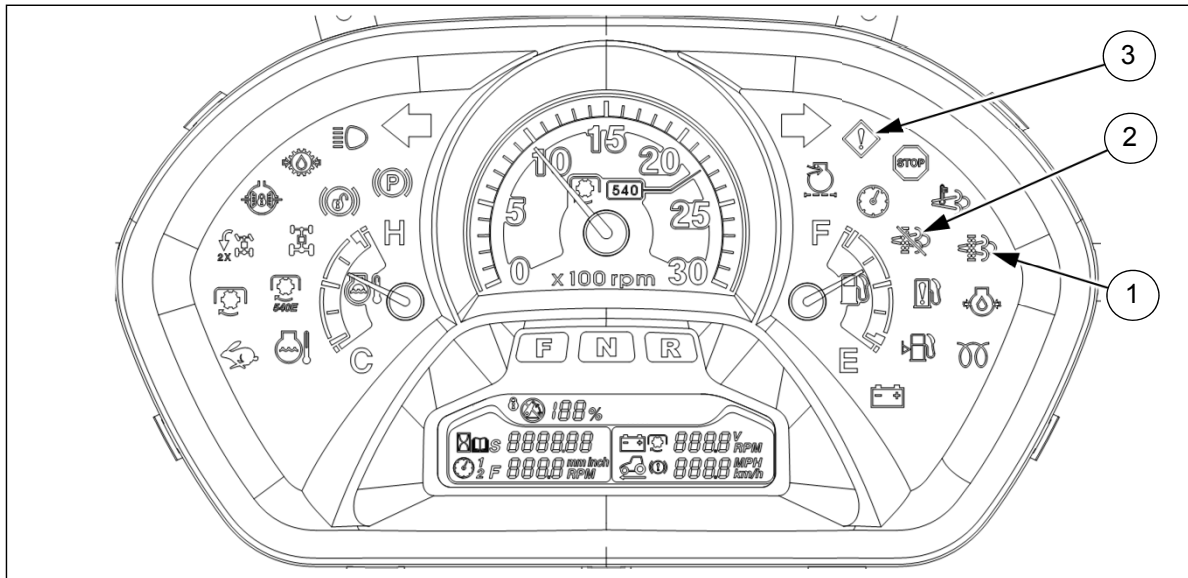

- Engine oil specification  
Use only DPF compatible (CJ-4) oil in your tractor engine.

<b>NOTICE</b>	<p>► Use of any engine oil other than (CJ-4) may clog the DPF earlier than expected and fuel usage may increase.</p>
---------------	--

#### ④ Indicator illumination on instrument panel

- The indicators related to the DPF regeneration have several illumination figures and its meanings as follows. Read carefully and keep in mind the instructions well.



Indicators	figures	Possible cause	Symptom & Actions	Remarks
1. DPF regeneration indicator	Continuous ON	When the regeneration is processing.	- Normal state	 +  ON ON
	BLINK(1sec)	When the soot's rate is over 120%	- Press and hold the upper side of the DPF switch over three second for regeneration.	 BLINK (1sec)
	BLINK(0.5sec) + Engine error warning indicator(3)	When the soot's rate is over 150%	Engine power reduction. HAVE TO contact your authorized local dealer for check.	 +  BLINK (0.5sec) ON
2. DPF regeneration inhibited indicator	Continuous ON	When the Inhibited regeneration mode is working	DPF regeneration is delayed or stopped.	 ON

## ⑤ Regeneration mode

- In this mode, the operator does not have to take any actions, the system is activated automatically by the engine electronic controller.

*NOTE : The regeneration is the normal operating mode.*

- The regeneration will be activated by ECU ;
  - When soot's rate **reaches 100% or more.**
  - When the engine **is warmed up enough.**
  - When **the DPF switch is not pressed to the Inhibited regeneration mode.**

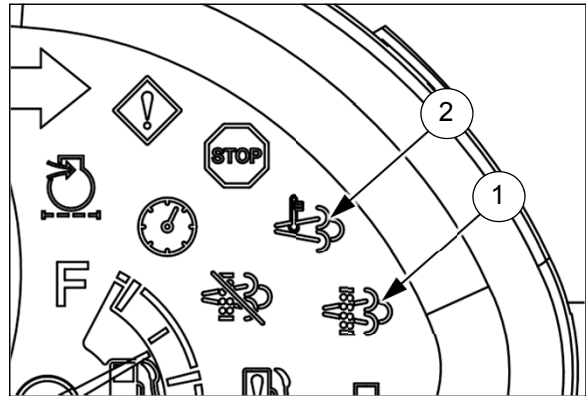

*NOTE : Regeneration will be lasted for approximately 15 to 25 minutes.*

- If pressing and holding the upper part of the DPF switch over 3 minutes, the regeneration can be activated manually. In this case, if the soot's rate is reached over minimum 30%, the regeneration will be activated.
- During the regeneration, the DPF regeneration indicator(1) and DPF temperature indicator(2) will be turned on.
- In case of turning off the engine while the regeneration is processing, the regeneration is to resume again when restarting the engine.

<p><b>NOTICE</b></p>	<p>▶ If engine is turned off during the regeneration, soot will not be completely burned and may increase fuel consumption. KEY-OFF during regeneration mode is not recommendable because too short operation won't finish regeneration mode, So, we recommend to users to operate until all indicator lights are turned off without Key switch OFF.</p>
<p> Warning</p>	<p>▶ Fire hazard! During the Diesel Particulate Filter(DPF) regeneration process, the exhaust stack and fixed hood area becomes extremely hot. Park the machine outside and away from combustible or highly flammable material. Failure to comply could result in death or serious injury.</p>

## ⑥ Inhibited regeneration mode

**NOTICE :** Only use this mode when regeneration needs to be delayed or stopped because of an operation condition that may risk a fire hazard due to high exhaust temperatures during regeneration.

**NOTE :** Even if the DPF regeneration indicator(1) is ON during the regeneration process, the inhibited regeneration mode can be set.

The regeneration mode can be delayed or stopped by the use of the DPF switch(3) that is located on the left-hand side of the dash.

### To set the inhibited regeneration mode :

1. Press down the lower side(B) of the DPF switch(3). And then DPF regeneration inhibited indicator(2) will be turned on.

**NOTICE :** When tractor arrives at a safe regeneration location, press again the lower side(B) of the DPF switch to exit the Inhibited regeneration mode.

If not, excessive soot in the DPF may overload the emission system and result in a reduction of engine power.

### To exit the Inhibited regeneration mode (To go to the regeneration mode) :

1. Press down the lower side(B) of the DPF switch(3) again for only exiting the inhibited regeneration mode.
2. Press and hold the upper side(A) of the DPF switch(3) for over one second to exit the Inhibited regeneration mode and to execute the regeneration mode.
3. When inhibited regeneration mode has been exited, the DPF regeneration inhibited indicator (4) will be turned off.

**NOTE:** If the tractor is shut off during the inhibited mode, when restarting the tractor, the regeneration system will return to the regeneration mode.

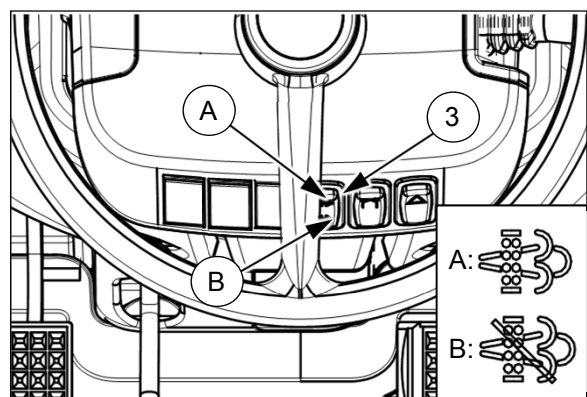
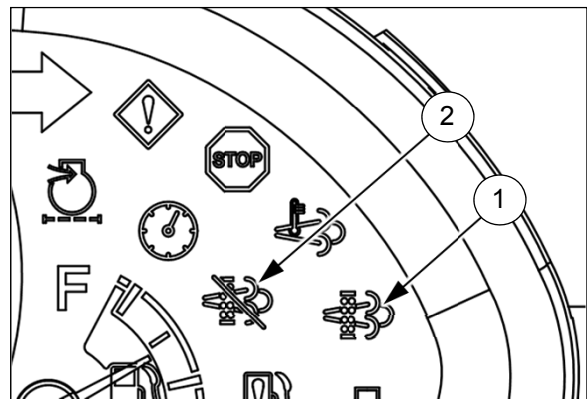

## (11) Beacon lamp switch (if fitted)

- It is used to turn on/off the beacon lamp connected to beacon connectors. The beacon connectors are installed on the left and right-hand side under the cabin roof.
- **ON** - press the upper side (symbol part) of the switch.
- **OFF** - press the lower side of the switch.

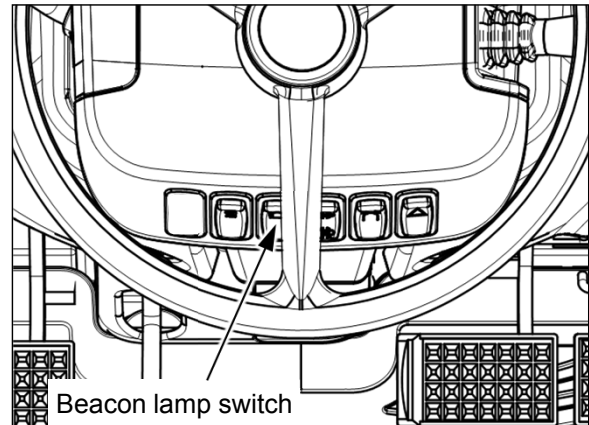
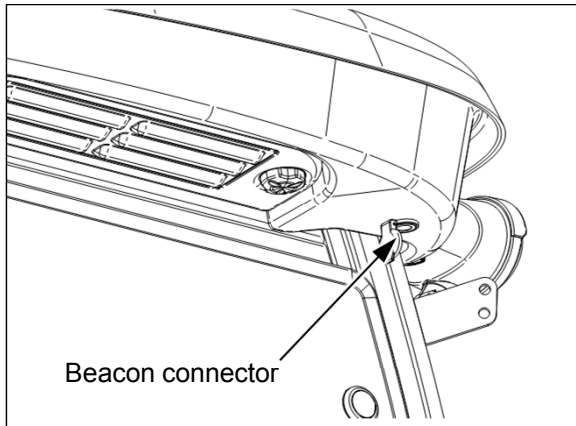

## (12) 540E PTO switch (if fitted)

- It is used to turn on/off the 540E PTO operation mode when working in the field.
- In this mode, the engine maximum speed will be restricted up to the designated engine speed related to the 540 PTO speed for economic PTO operation.
- When the PTO gear lever is in 750/540E rpm position and the PTO switch is turned on, if pressing this switch to "ON" position, the 540E PTO mode is ready.
- **ON** - press the upper side of the switch.
- **OFF** - press the lower side of the switch.

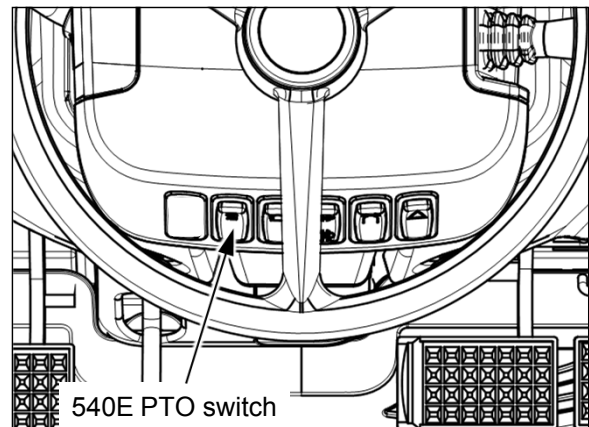

 Caution	<ul style="list-style-type: none"><li>▶ If placing the PTO switch or 540E PTO switch to "OFF" position or placing the PTO gear lever to other position except 750/540E position while the engine maximum speed is restricted, The 540E PTO mode may be exited and the engine speed can be suddenly increased.</li><li>▶ Before exiting the 540E PTO mode, lower the engine speed to idle rpm.</li></ul>
---	---

## 3-2. Right-hand controls and Cabin pillar

Important to owner, read carefully (Mechanical Hydraulic Lift)

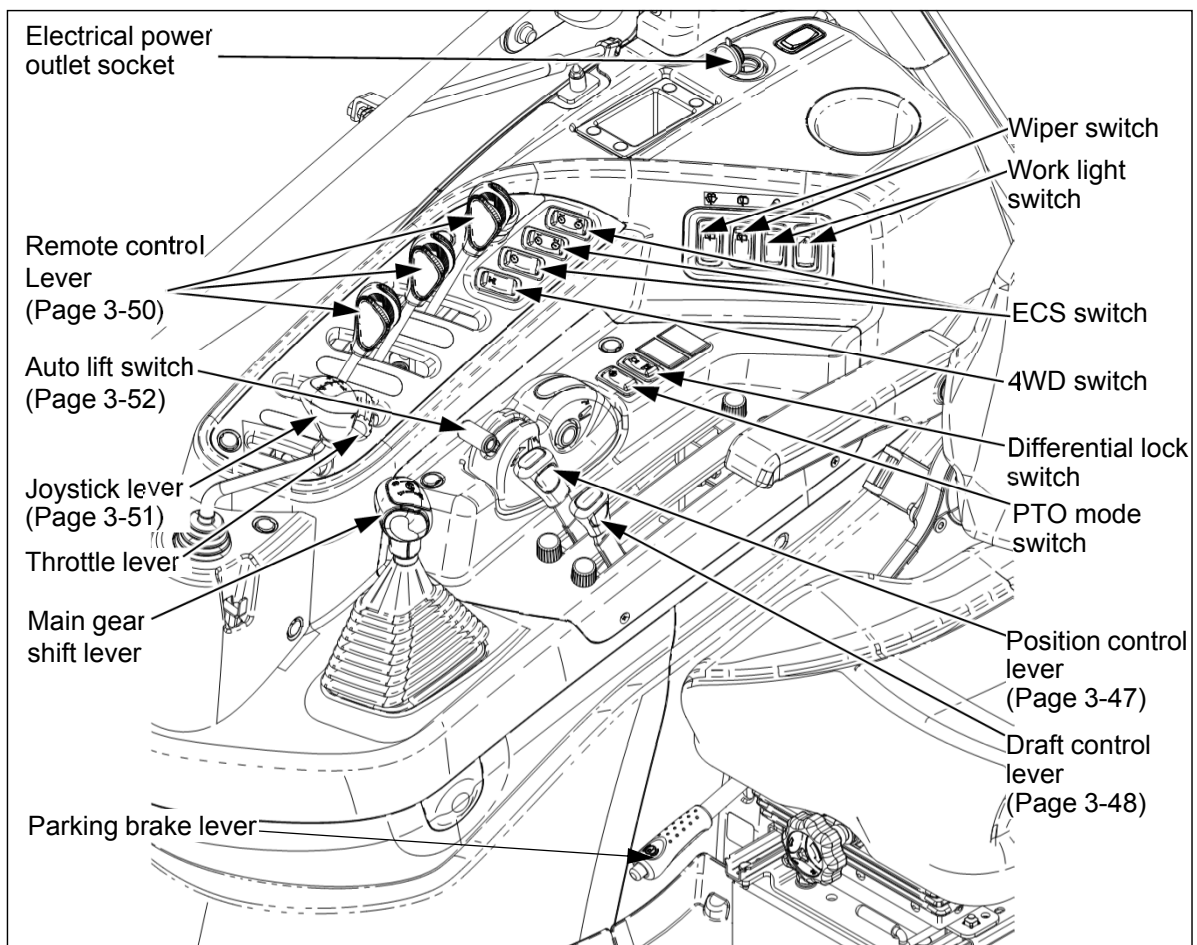

### (1) Throttle lever

- It is used to control the engine speed in field operation.
- DO NOT use this lever while driving on public roads. Place the throttle lever to the Low speed position and use the throttle pedal.
  - **Low speed** : Pull the lever backward
  - **High speed** : Push it forward.
- There is a sensitive electric sensor on the throttle lever. Do not remove/modify it arbitrarily.

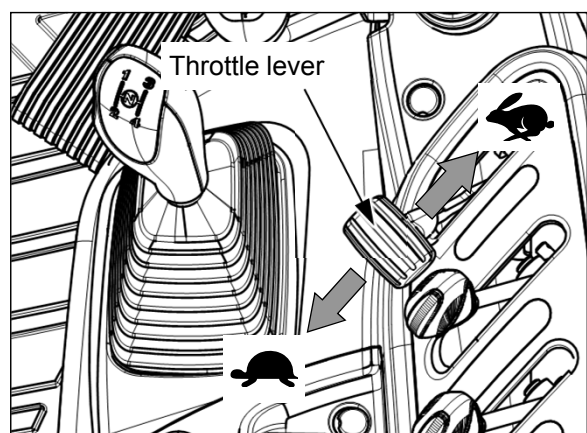



## Important to owner, read carefully (Electro-Hydraulic Lift)

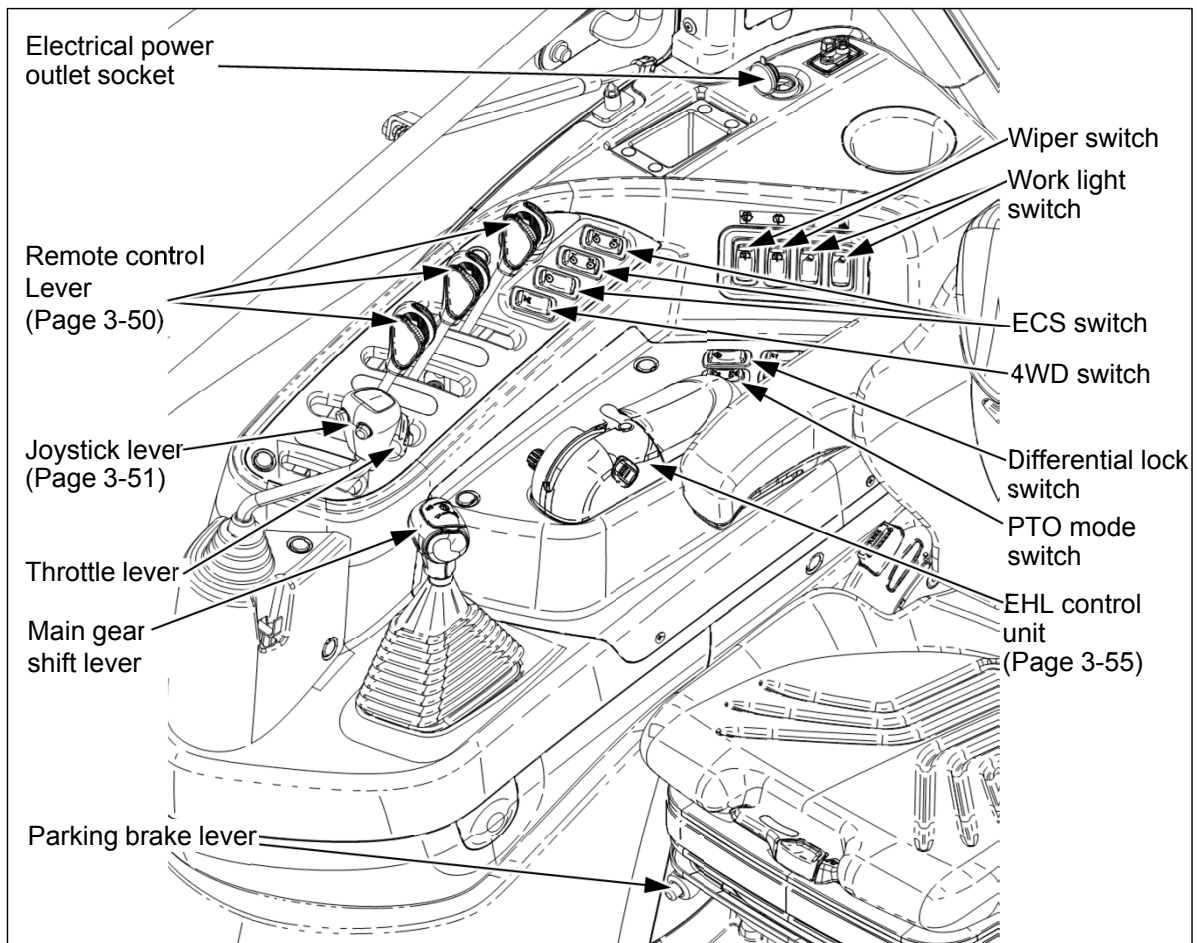

### (2) Main gear shift lever

- Four speed gear shift and neutral position is available.
- The main gear shift lever can be operated while driving after depressing clutch pedal. It is not necessary to stop the tractor completely due to the synchromesh gears.

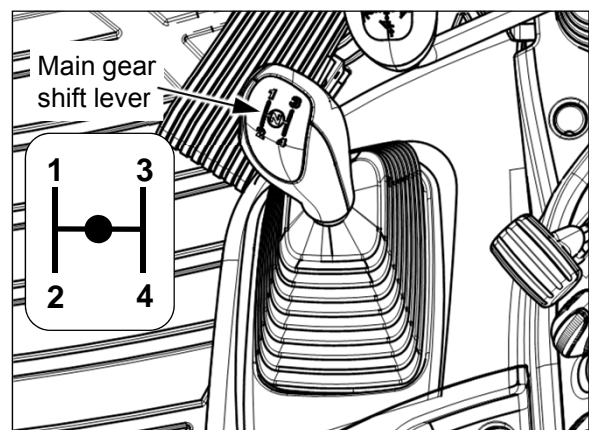

#### Notice

- ▶ Operate the main gear shift lever by correct "H" pattern. If operated diagonally, it may cause a failure.

### (3) Work light switch

#### ① Cabin type (Front, Rear)

- This is used to turn on/off the front/rear work lights.
- **ON** - Press the upper side (symbol part) of the switch.
- **OFF** - Press the lower side of the switch

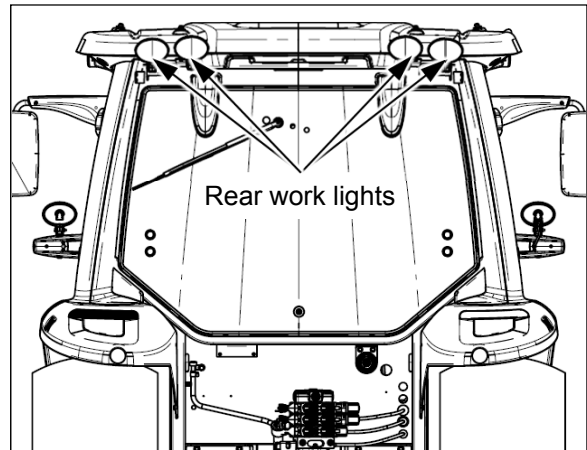
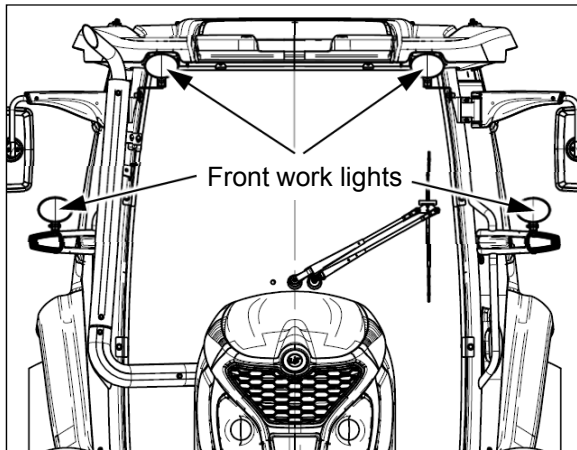
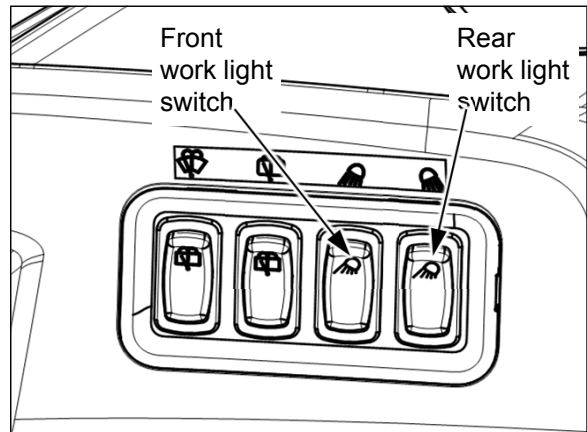

► When driving on the road at night, do not let the front/rear work lights stay ON. It may cause a disturbance to the driver of the oncoming/following car.

#### (4) Window wiper&washer switch (Cabin only)

- This switch is used for operating front and rear window wiper and washer.
- Press the upper side of its switch for operating only the front/rear wiper.
- If you press and hold the upper side of the switch again, the washer liquid will be sprayed out.

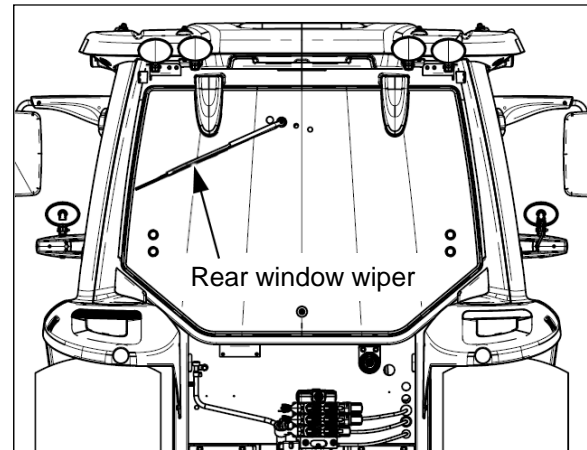
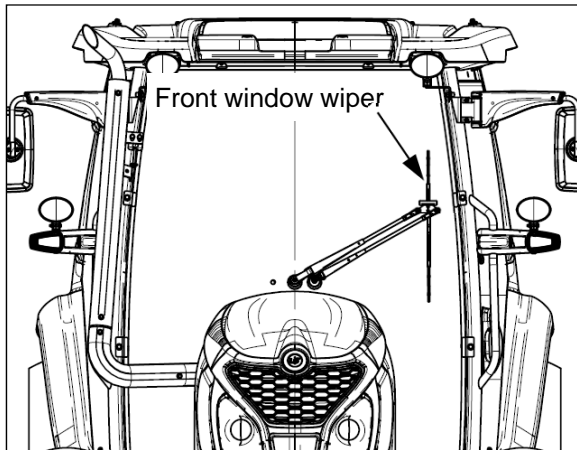
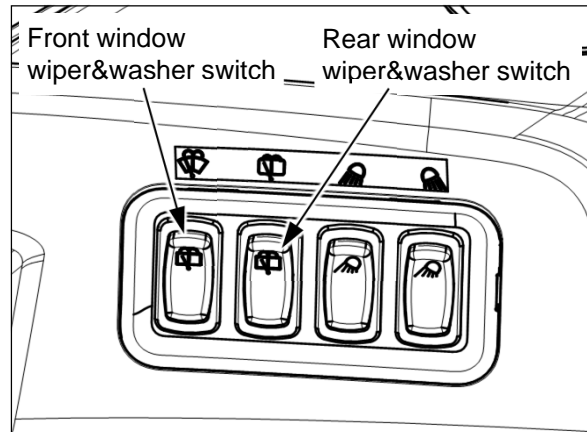



	▶ Use wind shield washer liquid for automobile in winter time.
	▶ Do not operate the wiper without wind shield washer liquid, it may cause damage to the wiper motor.

## (5) Electrical power outlet socket (Cabin only)

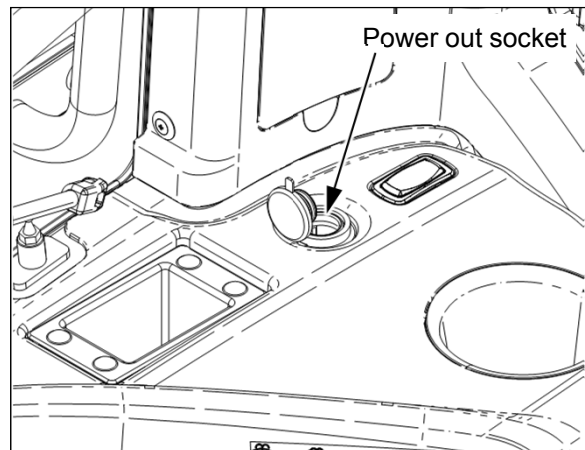
- This is used to withdraw electric power for charging of a cigarette lighter jack or cellular phone.
- In case of using a cigarette lighter jack(optional), push the cigarette lighter jack into the socket to heat the coil. If the heating is finished, the jack is retracted automatically, and it can be used as a substitute for a lighter.
- In case of using it as a power supply(12V), use a electrical equipment less than 8A of current flow.



 Caution	▶ When using a cigarette lighter jack, cares must be taken not to touch the heated coil. The heat generated coil is very hot and it may cause a serious burn.
	

## (6) Indoor light (Cabin only)

- To turn on the indoor light, press down the lower side of the indoor light.
- To turn off the indoor light, press down the lower side of the indoor light again.

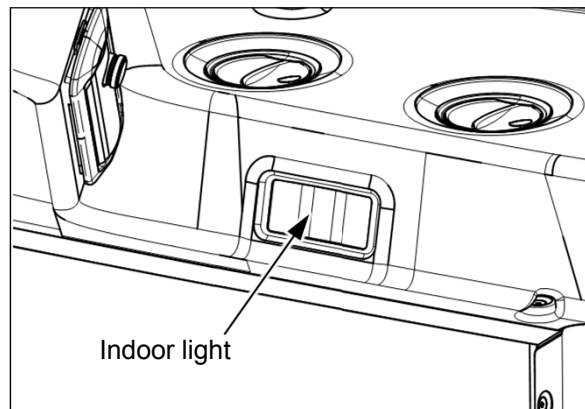

## (7) Audio player (Cabin only) (if fitted)

- Refer to the attached user's manual for Audio player.

 Caution	▶ To ensure safe operation, avoid turning up the player volume so high/loud. ▶ Do not use a headset while driving the tractor.
---	---

## (8) 4WD switch

- Press the upper side(symbol part) of the switch for Four wheel drive.(4WD)
- Press the lower side of the switch for 2WD.
- Front wheel drive (4WD) is effective for the followings.
  - When traction is needed in plow ground.
  - When working on slippery ground.
  - When working with tiller on hard ground.
  - When crossing a ridge

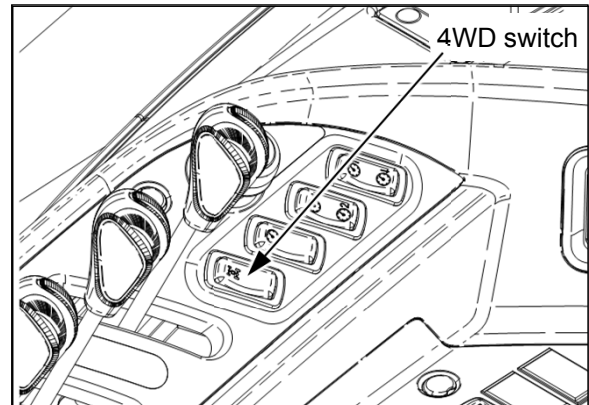

Caution

- ▶ When driving on public roads, disengage the 4WD. If not, it may cause damage of the tires and transmission drive line, and a serious accident due to rough steering by the front wheel drive. Before accessing the public road, disengage the 4WD.

## (9) Parking brake lever

- This lever is used to apply the parking brake.
- Pull the lever upward with pressing down the brake pedals after locking the brake pedals with brake pedal latch.
- To disengage the parking brake, pressing down the brake pedals, and push the lever downward after pressing the release button.

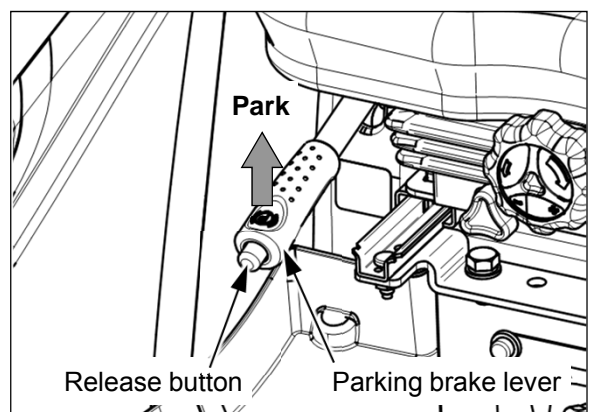

Caution

- ▶ DO NOT drive the tractor with the parking brake is engaged. It may cause damage of the brake or parking brake system.

## (10) Differential lock switch

- This is effective for working on a slippery ground. If the tractor cannot go forward as one side rear wheel is slipping, depress the clutch pedal and press down the upper side(symbol part) of the differential lock switch.
- If engaged, both rear wheels will rotate at a same speed and make it possible to move the tractor. But, it disturbs steering operation. After escaping from the slippery ground, release the differential lock.
- Push the lower side of the switch or press down the brake pedals once to release the differential lock. If the traction of rear wheels is equalized, the lock is released automatically.
- If the differential lock does not released, i.e. when turning to the right or left, the turning radius is larger than normal operation, depress the clutch pedal once and press one-side brake pedal slightly for a second, and then the other.

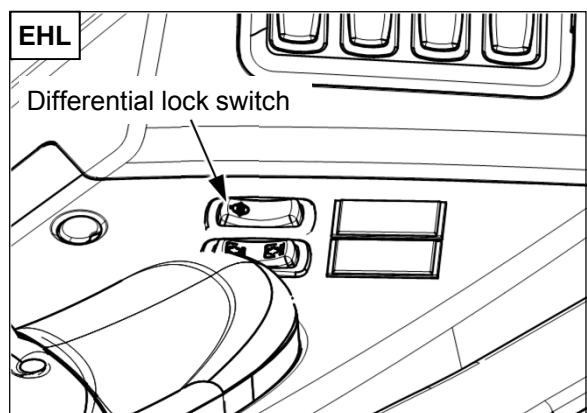
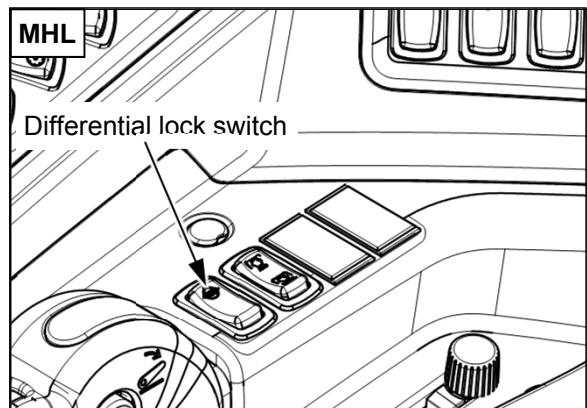

- ▶ Do not turn the tractor while the differential lock is engaged.
- ▶ Do not use the differential lock while driving on the road.
- ▶ Stop or slow the tractor before engaging the differential lock.

## (11) PTO mode switch (optional)

- It is used to select **AUTO** or **MANUAL** mode of the PTO operation
- When the PTO mode switch is placed on ;
  - **MANUAL**: PTO shaft will rotate independent on the clutch pedal or position control lever.
  - **AUTO**: If pressing the clutch pedal or lifting up the rear implement over the specified position, the PTO shaft will be stopped.

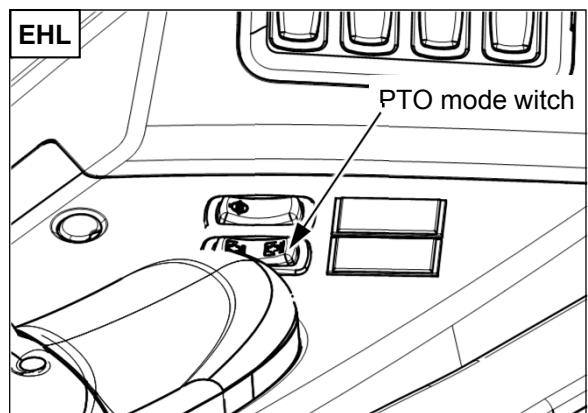
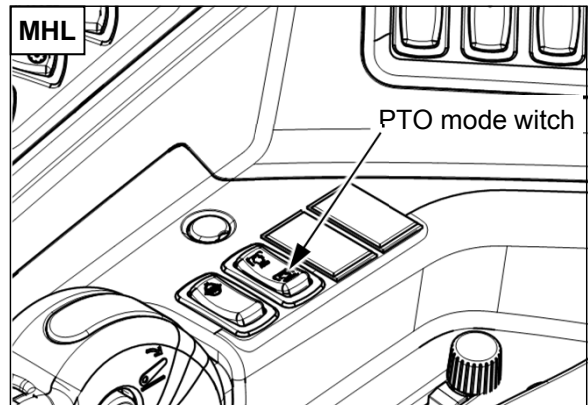

## (12) PTO switch

- The engine starts only when the PTO switch is placed in “OFF” position for safety.
- After starting engine, you must comply with the following instructions for PTO operation.
  1. Check the safety conditions around the implement.
  2. Place the PTO gear lever to the desired position.
  3. Select the PTO mode switch to “**AUTO**” or “**Manual**” position.
  4. Pull the PTO switch with pressing the lock button of the switch to engage the PTO. The PTO operation indicator will be ON.
  5. If you want to stop the PTO temporarily while operating, push the PTO switch in “OFF” position. The PTO shaft will be stopped.

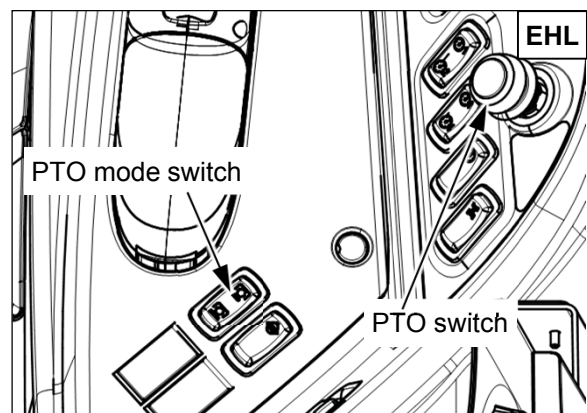
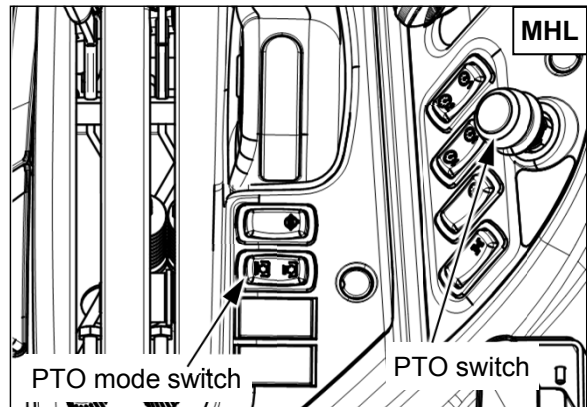
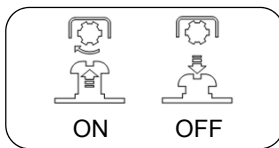

### Warning

- ▶ Before attaching, detaching or checking the PTO driven equipment, always place the PTO switch in “**OFF**” position, and PTO gear lever in neutral position.
- ▶ If the PTO mode switch is placed in **MANUAL** position, the PTO shaft rotates always regardless of the clutch pedal or position of the implement. Pay attention to the surroundings to prevent an accident.
- ▶ Do not engage the PTO clutch at high engine speed. Sudden engagement can cause damage to the implement and PTO clutch. Engage the PTO at low idle rpm, and then raise the engine speed up.



## (13) Engine Speed Cruise control (ESC) switch

### ① ESC main switch

- This switch is used to enable the Engine Speed Cruise control(ESC) function.
- If pressing the ESC main switch from position 0 to position 1 (**Off → Ready**),
  - ESC indicator on the instrument panel will be blinked.
  - Engine speed stored on ECU will be displayed on LCD panel.
- If pressing the ESC main switch from position 1 to position 2 (**Ready → Resume**),
  - ① (if pressing below 2 second) – ESC indicator will be ON and engine speed cruise control (ESC) will begin.
  - ② (if pressing over 2 second) – current engine speed will be stored on ECU and the stored engine speed will blink 3 times on LCD panel.
- To exit the ESC control,
  - Press the lower side (“Off position”) of the ESC main switch or press down the brake pedals.

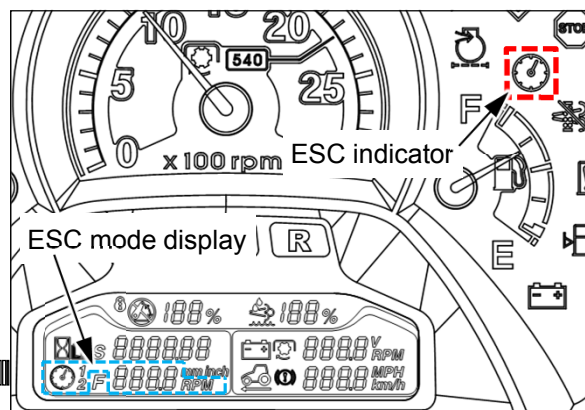
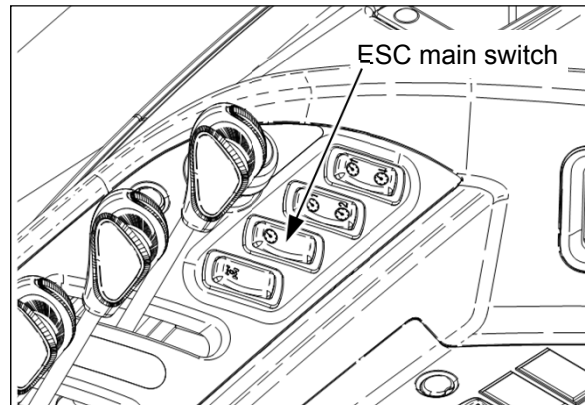

## ② ESC speed up/down switch

- This switch is used to adjust the engine speed for ESC when the ESC is working.
- If pressing the upper/lower side of the switch, the engine speed will be;
  - **Upper side: Increased.**
  - **Lower side: Decreased.**

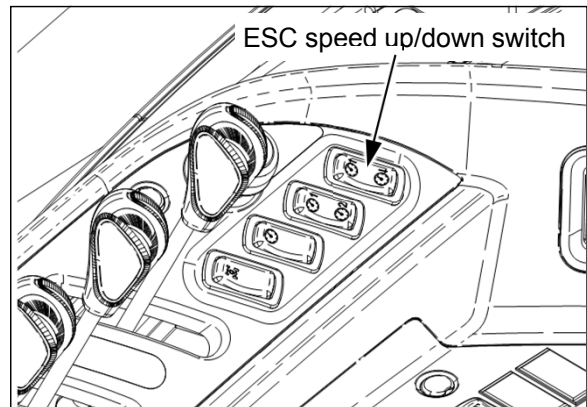

## ③ ESC mode select switch

- This switch is used to select an engine speed cruise control while the ESC is working.
- Two ESC mode is available.
- Press the upper or lower side of the switch to select an engine cruise control mode.

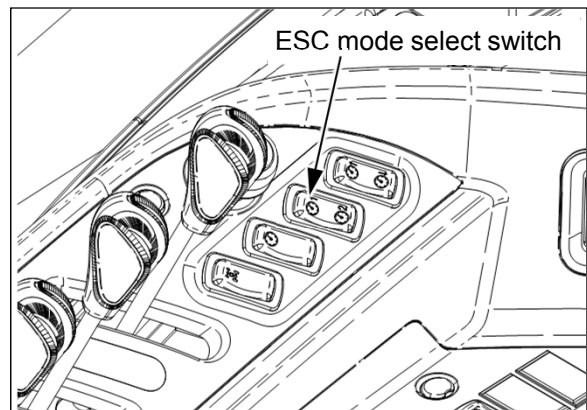

## 3-3. Left-hand controls

Important to owner, read carefully

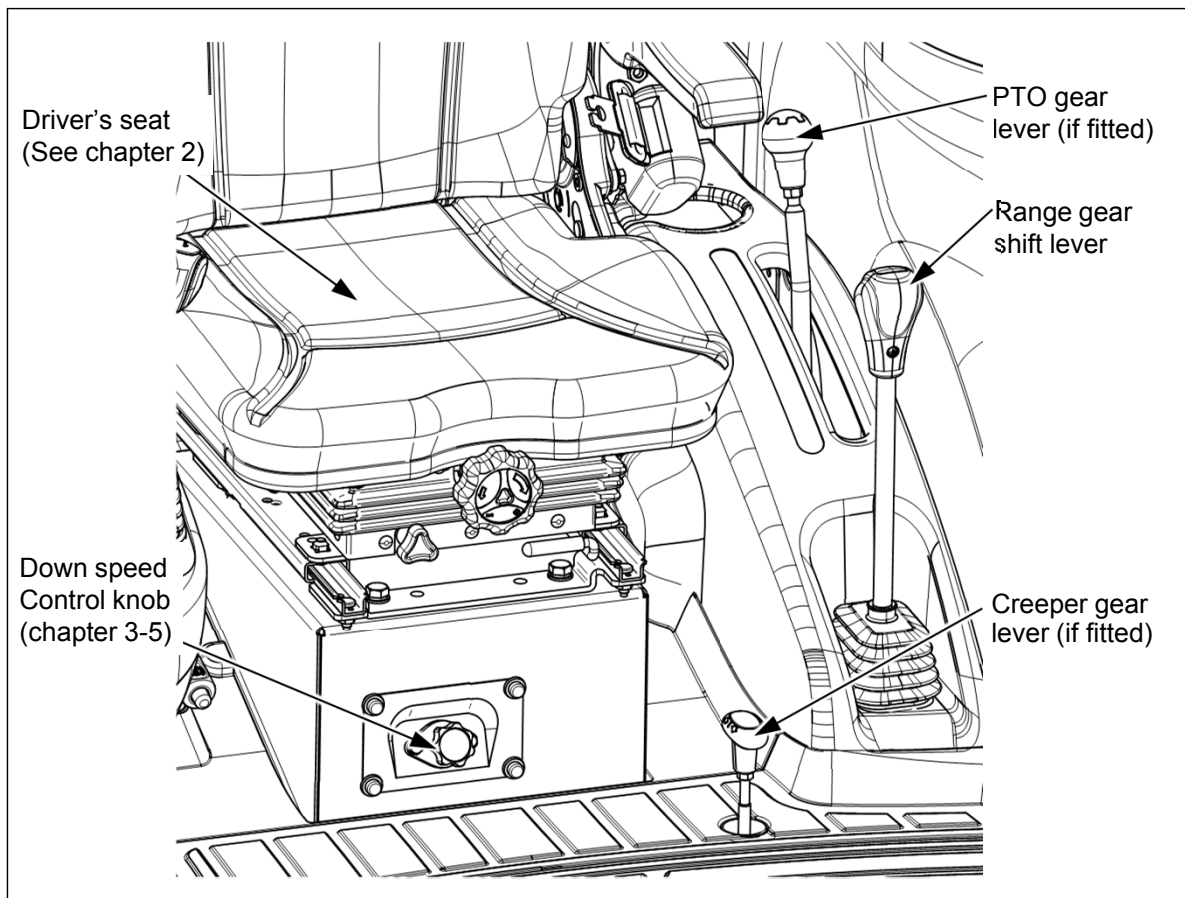

### (1) Range gear shift lever

- Three speed gear shift and neutral position is available.
- Before operating the range gear shift lever, press down the clutch pedal and brake pedals, and stop the tractor completely.
- When creeper gear is engaged, "H" speed range gear is not available. Before shifting the range gear shift lever to "H" range, move the creeper gear (if fitted) to the standard speed position.

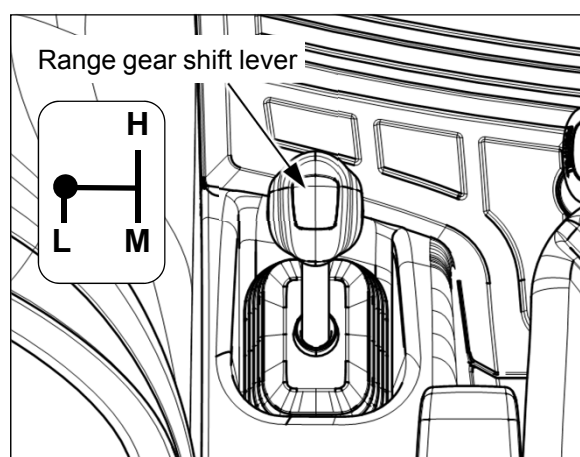



#### Notice

- ▶ Operate the range gear shift lever by correct "H" pattern. If operated diagonally, it may cause a failure.

## (2) Creeper gear lever (if fitted)

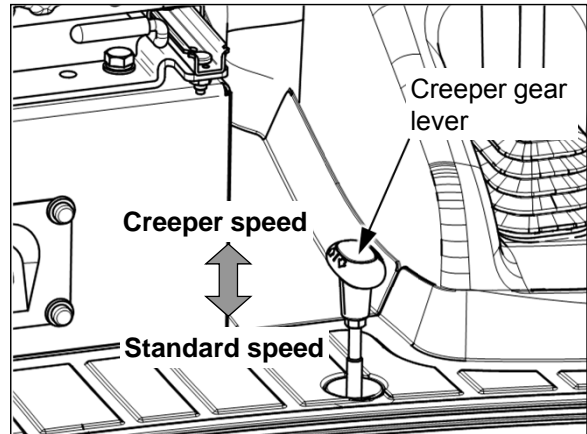
- It is used to engage/disengage the creeper speed gear.
  - Pull the lever upward for creeper speed
  - Push it down for standard speed.
- Before operating the creeper gear lever, press down the clutch pedal, brake pedals and stop the tractor completely.
- If the range gear shift lever is in “H” position, it is not possible to shift to the creeper speed range. After changing the range gear shift lever to “L” or “M” position, operate the creeper gear lever.



 <b>Caution</b>	<p>▶ As the driving force of the rear axle is very high in creeper speed range, the tractor may not be stopped even if pressing down the brake pedals. In this case, depress the clutch pedal together when pressing down the brake pedals.</p>
--	---

## (3) PTO gear lever

- 540 / 750 / 1000 rev/min and neutral position is available.
- Before operating the PTO gear lever, press the clutch pedal and put PTO switch in “OFF” position, and stop the PTO shaft completely.

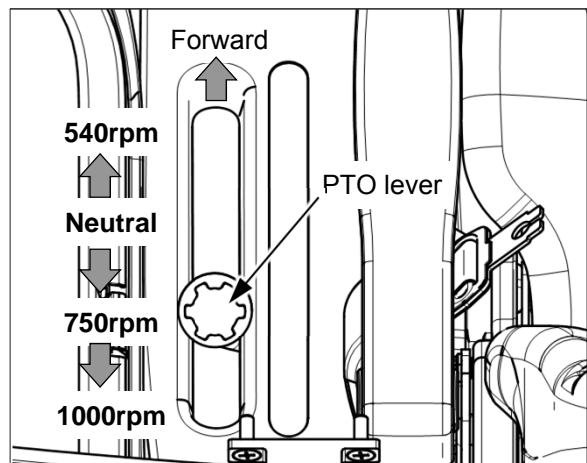

<b>Notice</b>	<p>▶ Operate the PTO gear lever by correct “I” pattern. If operated diagonally, it may cause a failure.</p> <p>▶ If the PTO gear lever is not engaged smoothly, shift the lever again after lifting up the implement from the ground to align the drive shaft.</p>
---------------	--

#### (4) Passenger's seat (if fitted)

- When using the passenger's seat, just lift the seat to the locked position.
- When folding the seat, push the passenger's seat lever to the outside and fold it down.

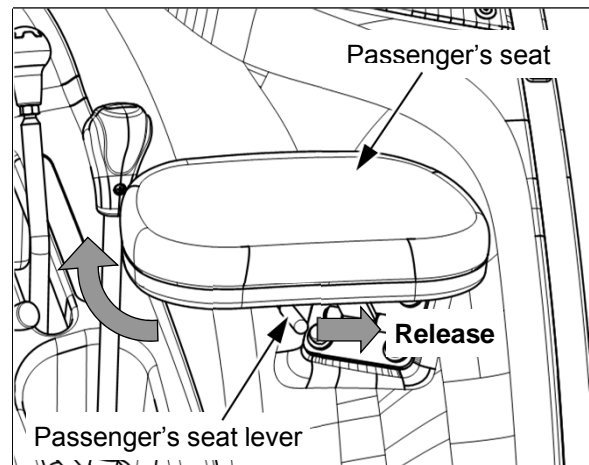

Warning

- ▶ This passenger's seat is an application for training or education about the tractor. DO NOT ride people on this seat while driving on the road.

### 3-4. Power Shuttle System (PSS) (if fitted)

#### (1) Power shuttle lever (PSS)

- Your tractor has an advanced electro-hydraulic forward and reverse system which controls the movement (Forward/Reverse/Stop) of the tractor by engaging or disengaging the multi-disk clutches.
- This system will provide you more convenient forward-reverse operation than mechanical synchro-shuttle system.
- To change the Forward/Reverse, after lifting up the power shuttle lever, just push it forward or pull it back without depressing clutch pedal.
- Before reversing the tractor, lower engine rpm and check behind you.

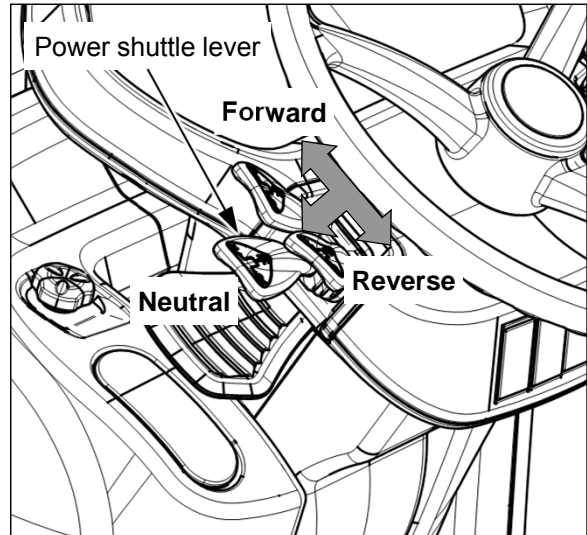

- If transmission oil temperature is below 10°C (50°F), the neutral (N) indicator on the instrument panel will blink to inform you that warm-up is needed. If the oil temperature goes higher than 10°C (50°F), the indicator will be turned off automatically.
- If the oil temperature is considerably lower than proper level, a shock due to sudden engagement of the power shuttle clutch may happen. Before operating the power shuttle lever, be sure to warm-up the engine and transmission oil sufficiently in cold weather.
- If shifting the power shuttle lever forward or reverse in the state of vacant driver's seat, the tractor does not move with alarming buzzer. Be sure to SEAT IN DRIVER'S SEAT.
- If shifting the power shuttle lever forward or reverse when the parking brake is engaged, the parking brake indicator will blink with alarming buzzer. Before shifting the shuttle lever, you must RELEASE THE PARKING BRAKE.

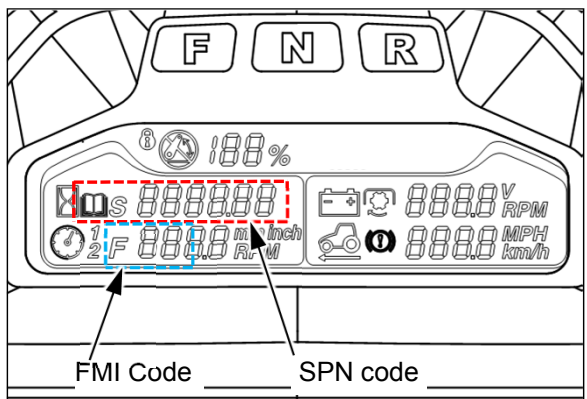
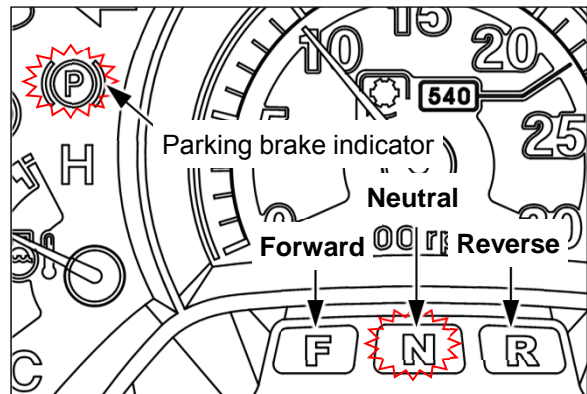

 <b>Warning</b>	<p>▶ When starting or shifting the power shuttle lever on a slope, always press down the brake pedals first, and release them at the moment when the vehicle starts. The vehicle can be moved forward or slipped backward during the engaging time of the clutch. It may cause roll-over accident. BE CAREFUL !</p>
--	---

- If the hydraulic pressure of the shuttle system goes lower than proper level during operation, corresponding error code (SPN, FMI code) will be displayed on the instrument panel with continuous alarm. At this time, move the shuttle lever to neutral position first. DO NOT try to operate the tractor any more, because the clutch engagement under a lower pressure can cause damage to the clutch plate even for a few seconds. Contact your authorized local dealer immediately to get some instructions or to check the problem. Even though the alarm sounds, the tractor can be moved restrictively for escaping from an emergency state.

 <b>Caution</b>	<ul style="list-style-type: none"> <li>▶ Before shifting the main gear shift lever or range gear shift lever, depress the clutch pedal fully to disengage the clutch completely. If not, it may cause damage to the transmission gear.</li> <li>▶ To start the engine, you have to place the power shuttle lever in neutral position and place the PTO switch in OFF position, and then depress the clutch pedal fully.</li> <li>▶ Before operating the shuttle lever, you should sit correctly in the driver's seat.</li> <li>▶ Before changing the direction of the tractor by using the shuttle lever, be sure to check the safety condition of your directions, especially in reverse.</li> <li>▶ It is dangerous to shift the power shuttle lever in high speed drive. Before changing direction, it is necessary to reduce the driving speed. If not, it may cause fatal accident and damage to the power shuttle clutch and transmission drive line.</li> <li>▶ Proper transmission oil temperature is necessary to the performance of the power shuttle system. Be sure to warm-up the tractor until the blinking of the neutral indicator is stopped and do not operate the tractor hastily, especially in cold weather.</li> <li>▶ Park the tractor on level ground and apply the parking brake. If you have to park the tractor on a slope, apply the parking brake, and apply the wheel chocks to the wheels. Engaging low speed gear is NOT useful to protect the slippage of the tractor having the power shuttle system.</li> </ul>
---	--

## (2) Clutch pedal (PSS)

- This pedal is used to engage or disengage the engine power for engine start, transmission shift and stopping tractor.
- To disengage the clutch, depress the clutch pedal fully. If PTO select switch is placed on “AUTO” and clutch pedal is fully depressed, the PTO shaft will be stopped.
- If the clutch pedal sensor has trouble or an error, the engagement or disengagement of the clutch is NOT smoothly operated and it's corresponding error code is displayed on the instrument panel with intermittent alarm. In this case, the tractor can be moved by using the power shuttle lever. After moving the tractor to safe area, contact your authorized dealer for check.
- To protect the radical wear of the clutch, if the engagement time is prolonged over 6 seconds, an alarm will happen, and if prolonged over 8 seconds, the clutch will be disengaged completely. In this case, operate the shuttle lever again from neutral position or depress the clutch pedal fully one time to recover the clutch system.
- When driving the tractor on a slope, especially with heavy loaded implements, select a suitable driving speed to start the tractor. Applying high engine rpm and long-lasting clutch engagement at a high transmission gear ratio can cause serious damage to clutch pack.

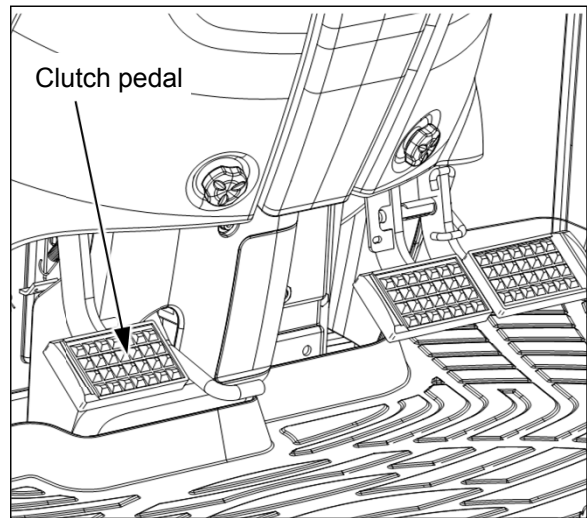



 Caution	<ul style="list-style-type: none"><li>▶ Depress the clutch pedal quickly and fully, and release it slowly.</li><li>▶ When starting the engine, depress the clutch pedal fully. If not, the engine may not start due to interlocking of the start safety switch for user's safety.</li><li>▶ Do not ride your foot on the clutch pedal while driving.</li><li>▶ If the engagement time is prolonged over 8 seconds on a slope, the engine power will be cut off by safety interlock system. It means that tractor can slip down and your special care must be taken. At this time, press the brake pedals immediately and recover the power shuttle system by depressing the clutch pedal fully or re-operating the shuttle lever from the neutral position.</li></ul>
---	---

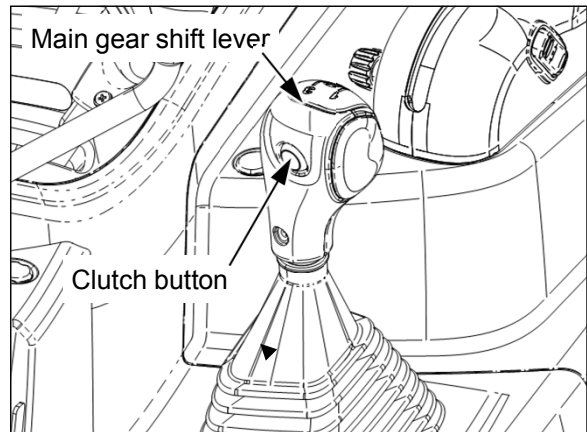

### (3) Clutch button (PSS)

- It is used to engage/disengage the main clutch before shifting the main gear shift lever instead of the clutch pedal.
- If pressing/releasing the clutch button, the engine power will be disengaged/engaged.
- When pressing this button, the neutral indicator on the instrument panel will blink.



 <b>Caution</b>	<ul style="list-style-type: none"> <li>▶ Be careful that this clutch button is NOT pressed by unintended operation.</li> <li>▶ Use this button only for shifting the main gear shift lever while driving. If using this button when starting, the engagement shock can be increased considerably.</li> </ul>
--	--

### (4) CAL/SEL switch (PSS)

- This switch is used to calibrate automatically of the power shuttle system oil pressure.
- EHL : Electric hydraulic lift models  
MHL : Mechanical hydraulic lift models
- Comply with the following instruction;
  1. Start engine and release the parking brake on a level surface.
  2. Place the power shuttle lever, main gear shift lever and range gear shift lever.
  3. Put throttle lever to the “Low” speed.
  4. Press this switch over 3-seconds with depressing clutch pedal fully to start the automatic oil pressure calibration mode.
  5. Place the power shuttle lever to the forward or reverse position. The automatic oil pressure calibration will start.
  6. After the process is finished, place the power shuttle lever in neutral position.
- To stop the calibration mode during the process, place the power shuttle lever in neutral position.

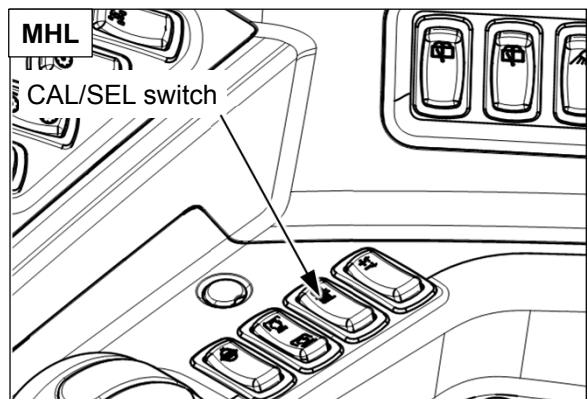
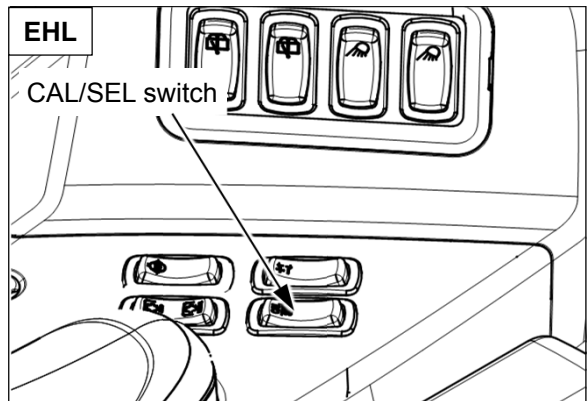

 <b>Caution</b>	<ul style="list-style-type: none"> <li>▶ Be careful that this switch is not pressed by unintended operation.</li> </ul>
--	---

## (5) Engaging speed +/- switch (PSS)

- It is used to adjust the engaging speed of the power shuttle clutch when operating clutch pedal or power shuttle lever.

- **Engaging speed adjustment of the clutch pedal;**

1. Press the upper side (symbol part) of the engaging speed +/- switch **with depressing clutch pedal fully**.
2. The engaging speed level will be displayed on the instrument panel from level 1 to level 3. The higher the number is, the faster the engaging speed is.
3. If pressing the upper side (symbol part) of this switch within 5 seconds, the engaging speed level is increased. Otherwise, the level is decreased.
4. The changed level is saved after blinking 3 times.

- **Engaging speed adjustment of the power shuttle lever;**

1. Comply with the same process of the clutch pedal engaging speed adjustment **without depressing clutch pedal**.
2. The engaging speed level will be displayed from level 1 to level 9.

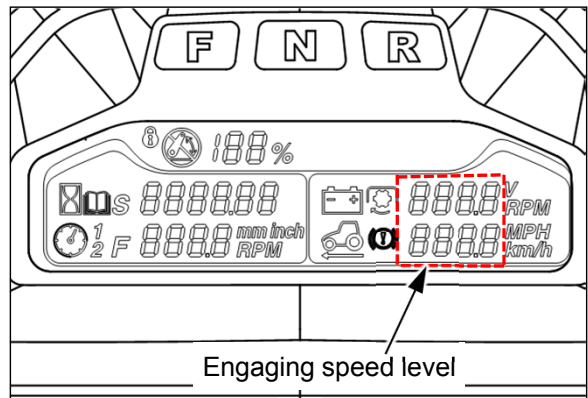
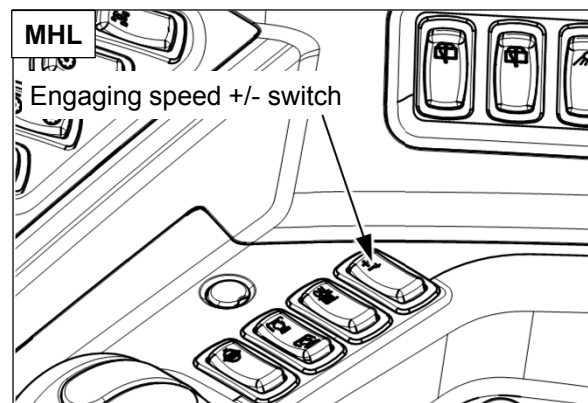
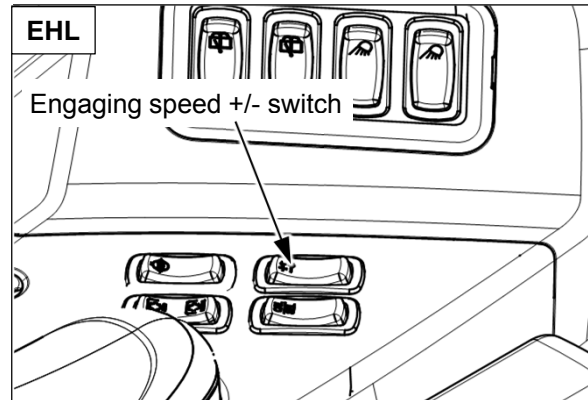

 <b>Caution</b>	<p>► If pressing this switch over 10 seconds, it will be a useless thing and it may cause malfunction. Be careful that this switch is not pressed by unintended operation.</p>
--	--

## (6) Error Diagnosis Code (PSS)

- If a sensor or a valve related to the power shuttle system has failed, the corresponding error code, SPN code and FMI code will be displayed on the instrument panel as shown in the figure. Refer to the next page for SPN code and FMI code.
- In case of several errors, the errors will be displayed by turns every 1 second. In this case, record all error codes.
- If any error code is displayed, contact your authorized dealer for check and tell the error code.

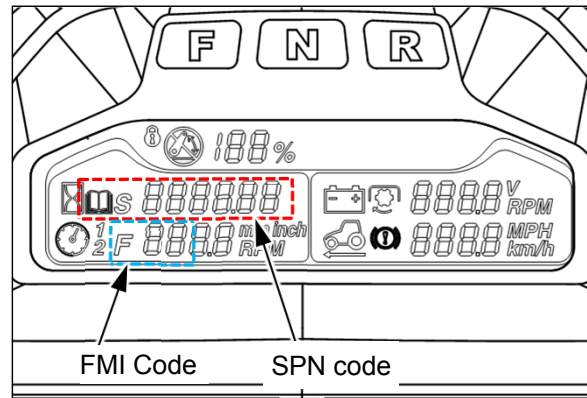



## (6) Error Diagnosis Code (PSS) - continued

SPN	FMI	Component	Description
100000	03	F/R Lever	Shuttle lever sensor Short to PWR source
	04		Shuttle lever sensor Short to Ground
	02		Shuttle lever sensor & Neutral Switch Error
100100	03	Clutch Pedal	Clutch pedal sensor Short to PWR source
	04		Clutch pedal sensor Short to Ground
100200	02	Clutch Button	Clutch Button Error
100300	02	Rangeshift SW	Rangeshift Switch Error
100400	02	Hi/Lo SW	Hi/Lo Switch Error
100500	02	Calibration SW	Calibration Switch Error
100600	02	Up/Dn SW	Up / Down Switch Error
110000	03	Signal PWR Sensor	Signal PWR sensor Short to PWR source
	04		Signal PWR sensor Short to Ground
	16		Over the normal operating region (Signal PWR)
	18		Below the normal operating region (Signal PWR)
110100	03	Controller Power Sensor	Controller Power sensor Short to PWR source
	04		Controller Power sensor Short to Ground
	01		Below the normal operating region (Controller Power)
110200	03	System Pressure Sensor	System Pressure sensor Short to PWR Source
	04		System Pressure sensor Short to Ground
	18		Below the normal operating region, least severe level (System Pressure)
	00		Below the normal operating region, most severe level (System Pressure)
110300	03	TM Oil Temp. Sensor	TM Oil temperature sensor Short to PWR source
	04		TM Oil temperature sensor Short to Ground
	-		Over the normal operating region (TM Oil temperature)
	-		Below the normal operating region (TM Oil temperature)
110400	08	TM Speed Sensor	TM speed sensor Error
120000	05	Forward Valve	Forward valve short to Ground
	06		Forward valve short to PWR source
	02		Over / Below the normal operating region (FWD valve current)
120100	05	Reverse Valve	Reverse valve short to Ground
	06		Reverse valve short to PWR source
	02		Over / Below the normal operating region (REV valve current)
120200	04	Hi/Lo Valve	Hi/Lo valve short to Ground
	03		Hi/Lo valve short to PWR source
120300	04	Lub Vavle	Lub valve short to Ground
	03		Lub valve short to PWR source
130100	19	No data from ECU	Communication error with Engine Controller

## 3-5. Hydraulic system

### (1) Safety precautions

- Hydraulic oil leaking under pressure can penetrate skin and cause infection or other injury. To prevent personal injury, comply with the instructions as below.
  - . Relieve all pressure before disconnecting hydraulic lines.
  - . Before applying pressure, make sure all connections are tight and components are in good condition.
  - . Never use your hand to check for suspected leaks under pressure.
  - . If injured by leaking fluid, get medical attention immediately.
- The hydraulic hoses and fittings on your tractor meet engineering specifications for the particular function. When replacing damaged parts, use only manufacture authorized service parts.
- Care in hydraulic hose installation is a must:
  - . Make sure pressure is relieved before starting installation procedure.
  - . DO NOT kink or twist a hose, failure may occur. Properly route the hose.
  - . Have a certified hydraulic technician install the hose.
  - . Remove air from the hydraulic system after installing any hydraulic component.
- Periodically check hydraulic system for leaks or damaged parts - kinked, crushed, flattened, hard blistered, heat cracked, charred, twisted, soft or loose covered hoses and fittings.
- DO NOT pull or apply external forces to the hose. The hose may fail and cause injury.
- Keep all persons away from the working area. If a hose fails, mechanisms controlled by fluid power can become hazardous. Lifted mechanisms can fall to the ground, steering system may fail, etc.
- Stay clear of a pressurized hose assembly that has blown apart. Hose fittings can be thrown off at high speed and a loose hose can whip around with great force.
- Hydraulic oil can reach high temperatures. *Wait for all components to cool before you perform any maintenance or adjustment operation. Do not handle any service fluid (engine coolant, engine oil, hydraulic oil, etc.) at temperatures that exceed 50 °C (122 °F). Allow fluids to cool.*
- Vibration can reduce hose service life. Make sure all retaining clamps and/or devices are secured.
- Environmental conditions can cause hose and fittings to deteriorate. *You must periodically inspect the hydraulic hoses. See the Maintenance chapter for general inspection precautions. The hoses do not require any operator-performed maintenance. Always see your authorized local dealer for hydraulic hose repair or replacement.* Replace worn or damaged hoses and fittings.
- Before checking or repairing the hydraulic system, make sure the engine is stopped, and all the transmission gears are in neutral, and lower the implements to the ground.

 <b>Warning</b>	<ul style="list-style-type: none"> <li>▶ Before removing hydraulic pipes or hoses and other parts, make sure to check that hydraulic pressure is relieved completely. The leaks of pressurized oil can cause a fatal physical injury.</li> <li>▶ Use proper protection equipment, before servicing the hydraulic system.</li> <li>▶ Before connecting or disconnecting the hydraulic quick couplers, lower the implements to the ground, and check if the hydraulic pressure is relieved.</li> </ul>
	

## (2) Steering system

- The hydraulic steering system controlled by fluid power provides you more convenience to operate the steering wheel.
- Notices when using the steering system.
  1. If there is too much of a load in front-end loader bucket, it could be difficult to operate the steering wheel. In this case, it is necessary to reduce the size of the load.
  2. Do not operate the tractor unnecessarily in a state of fully steered front wheels for a long time. As unnecessary hydraulic force is applied to the steering linkage, it may cause damage to the steering system and excessive increase of the hydraulic oil temperature which may cause reduction of the product life or a failure of the hydraulic and steering system. Especially, DO NOT operate the steering wheel excessively when a front wheel is mired in a ditch. The rim and disk of the wheel could be damaged or deformed.
  3. If an abnormal noise sounds off when operating the steering wheel, this may mean that there is some air in the steering components or lines. In this case, turn the steering wheel to the left and right direction fully about 2~3 times. It will exhaust the air and the abnormal noise will disappear. If it's not cleared, contact your authorized local dealer for check.
  4. When starting engine in cold weather, an abnormal noise may occur. In this case, warm up the tractor before using it in order to reduce the oil viscosity.

Notice	<ul style="list-style-type: none"><li>▶ When the engine is stopped, the steering wheel becomes hard to turn. But this does not mean a failure. It can be only used in an emergency state.</li><li>▶ When releasing the steering wheel after steering operation while driving, the steering wheel does not return to neutral position automatically.</li></ul>
--------	---

### (3) Hydraulic lift Control (Mechanical Hydraulic Lift, MHL)

- The hydraulic lift system is operated by the position control and draft control lever.

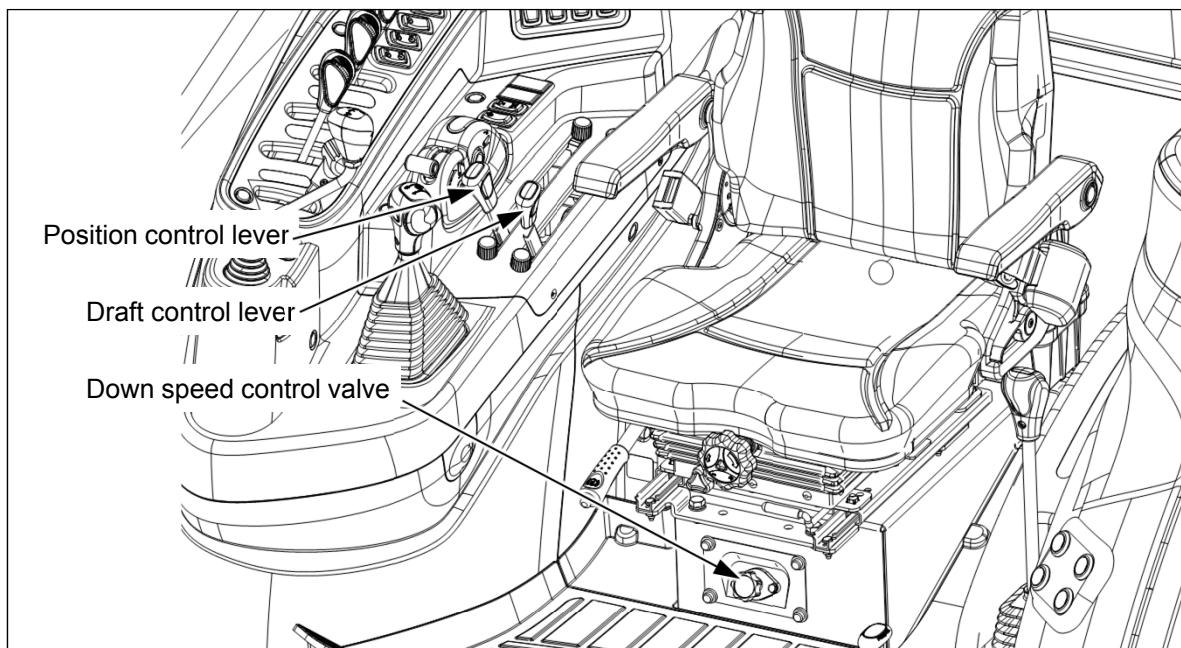

#### ① Position control

- To set the position (height) of the rear implement, move the position control lever up/down during the engine is running. Generally, this lever is used for tiller, fertilizer distributor, mower, rake and other rear implements.

1. Push the position control lever forward and let the implement down by its own weight.
2. Move up the lever to desired position, the rear implement shall be located on the position corresponding to the lever position.
3. To set the lowest position of the lever, turn stopper A counter-clockwise, move and tighten it at the desired position.

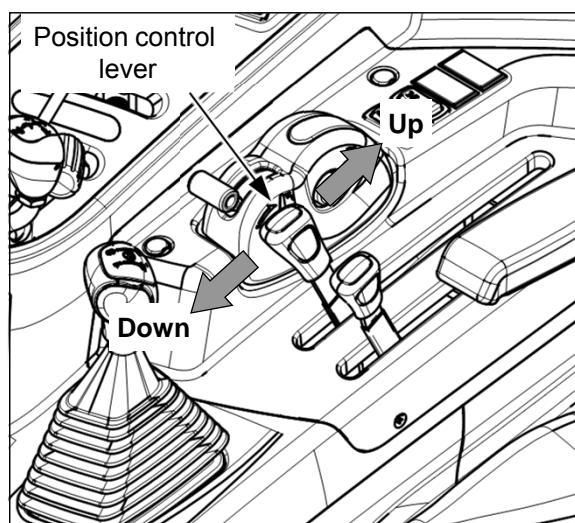

## ② Draft control

- The working depth of the implement under the draft control is controlled automatically by the draft load of the implement that detected from draft load sensor bracket and transmitted to the lift control valve. Generally, this mode is used for the implement which receives the draft load. In this case, operate the lever as follows.

1. Remove the draft sensor stopper of the upper link bracket.
2. Move the position control lever forward fully (Down) and let the implement down by its own weight.
3. The draft load delivered to the lift control valve will be determined according to the position of the draft control lever. That is, the more the lever moves back (up), the more the implement rises up by light draft load.
4. If you want to lift the rear implement, use the position control lever instead of the draft control lever.

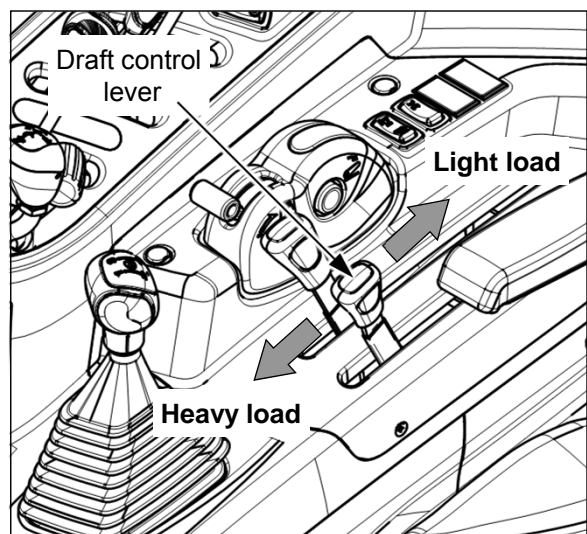
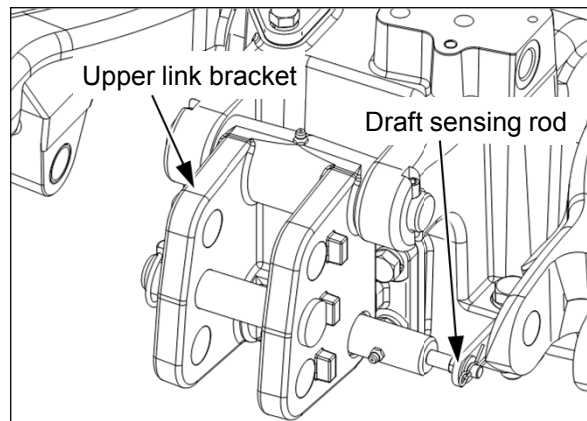

## ③ Mixed control

- If using above two levers in combination, mixed control is available. Set the position of the implement first, and set the draft control lever depending on the draft load. At this time, working depth can be controlled by the draft control lever under position control mode.



#### ④ Down speed control knob

- It is use to adjust the down speed of the 3-point linkage. Turn the down-speed control knob to the right direction for slower down-speed of the implement, and to the left direction for faster down-speed.
- If turning the knob right direction fully, the implement will be fixed and even if lowering down the position control lever, the implement does not let down.
  - Tiller: Slow in down speed
  - Plough: Fast in down speed
- When working in hard ground, slow down the down speed to avoid bounding of the implement.

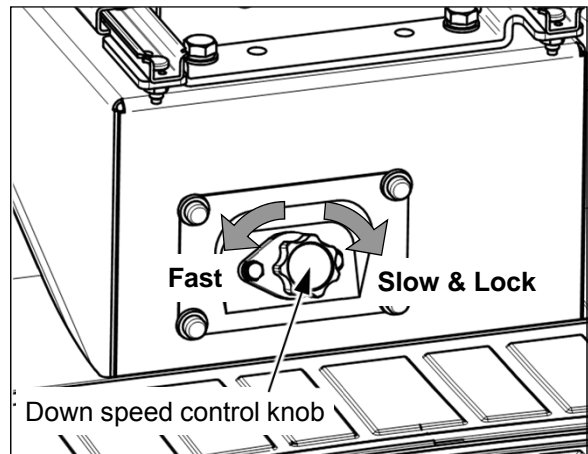

 <b>Warning</b>	<ul style="list-style-type: none"><li>▶ When driving on the road, replacing tiller blades or removing grass around the tiller blades, turn the down-speed control knob clockwise slightly to lock.</li><li>▶ The knob rotates about two revolutions. Do not over-tighten the knob. It may cause damage to the control valve and connection parts.</li></ul>
---	---

## (4) Remote control lever and Quick coupler (optional)

- These remote control levers are used to operate the hydraulic cylinder and/or motor of the implement attached to your tractor.
- If you **push** the remote control lever(s) **forward**, the hydraulic pressure works **to the left-hand coupler(s)** of the related lever(s), and **the right-hand coupler(s) is connected to the drain line**.
- Each lever of this parallel circuit remote control valve can be operated independently. But, when operating these levers at the same time, a quick coupler under less pressure may begin to work first.
- After connecting and preliminary operating the hydraulic equipment, check again the transmission oil level of the tractor.
- Depending on the type of remote control valve, a spring-return type, detent type or a combination of these types can be installed on your tractor. (optional)
  - **Spring-return type:** When releasing the lever after pushing/pulling fully, the lever returns to the neutral position automatically.
  - **Detent type:** When releasing the lever after pushing/pulling fully, the lever is fixed on that position. In this case, you must move the lever to the neutral position manually after using it. *If leaving this lever on, it may cause an over-heat and serious damage of the hydraulic system.*
  - **Detent with auto-release type:** When releasing the lever after operating fully to the float position (optional), the lever is fixed on that position. If the system pressure of the actuator line is over the designated level, the remote control lever will return to the neutral position automatically.

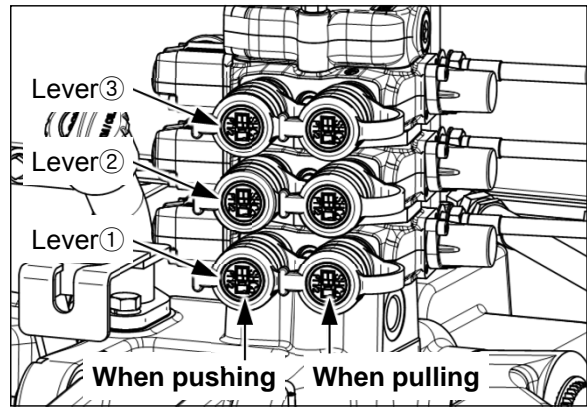
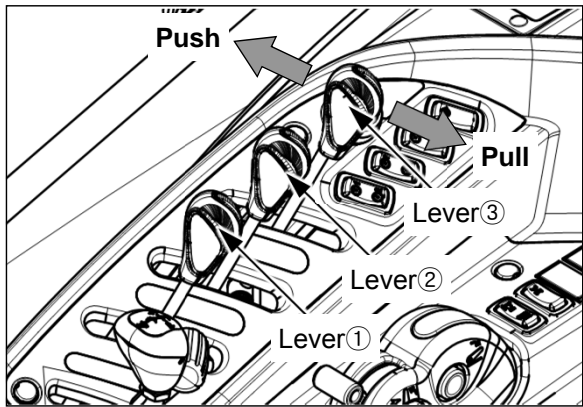

<p><b>Warning</b></p>	<ul style="list-style-type: none"> <li>▶ Before removing the hydraulic pipes, hoses or other parts, make sure to check that the hydraulic pressure in the hydraulic lines is relieved completely. The leaks of pressurized oil can cause a fatal physical injury.</li> <li>▶ Use proper personal protection equipment before servicing the hydraulic system.</li> <li>▶ Before connecting or disconnecting the hydraulic quick couplers, lower the implements to the ground, and check that the hydraulic pressure is relieved.</li> </ul>
-----------------------	--

<p><b>Caution</b></p>	<ul style="list-style-type: none"> <li>▶ When connecting a high volumetric capacity cylinder to the remote control system, lower the implement to the ground, and check if the transmission oil level is marked between "Min" and "Max" scale on the oil gauge. If necessary, add new oil.</li> </ul>
-----------------------	---

## (5) Joystick lever (optional)

- Remote control joystick lever helps to operate the front-end loader comfortably.
- The joystick lever can be operated basically in four directions as shown in the right figure.
- If you move the joystick lever diagonally, loader and bucket cylinders will be operated at the same time. In this case, the light loaded cylinder may be moved first.
- If you want to float the bucket along the ground, lower the front-end loader and push forward the joystick lever to the float position. After finishing work, pull the lever and place it in neutral position.
- Locking lever shown in the right figure is used to lock the joystick lever.
  - **Pull outside : Unlock**
  - **Push inside : Lock**
- *For further information, see chapter 4-5-(7) "Using Front-end loader" in this manual.*

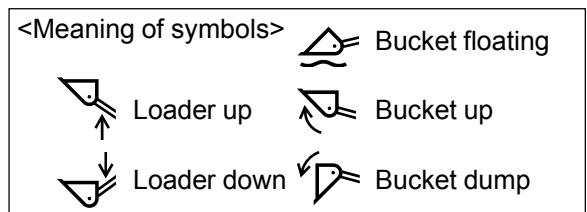
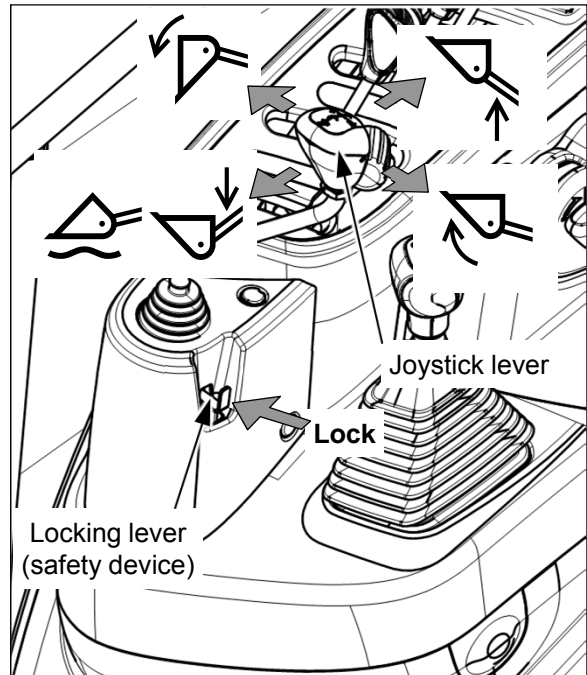

	<b>Warning</b> ▶ To prevent an accident, lock the joystick lever with the locking lever when not in use.
--	--

## (6) Auto lift control (MHL, if fitted)

- ※ It is used to lift the implement up to the highest position quickly and lower it down to the position set by position control lever without using the position control lever.
- Pull the auto-lift-up switch backward to lift up the implement.
- Press the auto-lift-down switch to lower down the implement. At this time, the auto-lift-up switch returns forward automatically.
- When the auto-lift-up switch is pulled back, the implement will NOT be moved by position control lever.
- When lifting up the implement, the PTO shaft will be stopped in case that the PTO mode switch is placed in “**AUTO**” position. (optional)

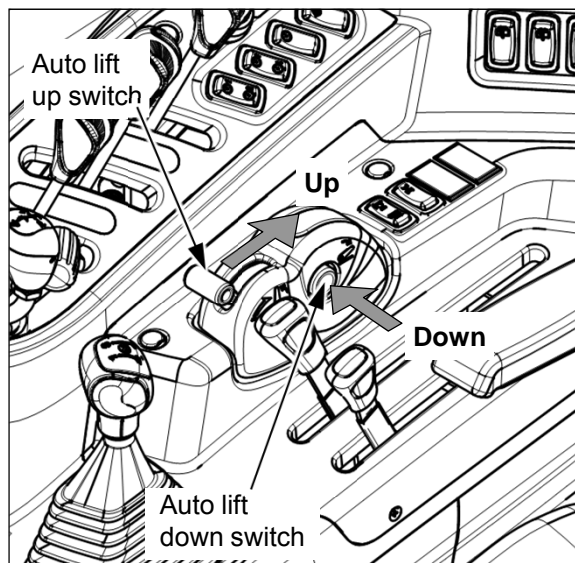

 <b>Warning</b>	<ul style="list-style-type: none"><li>▶ When driving on the road, lift up the implement with the position control lever and lock the down speed control knob slightly.</li><li>▶ When lifting up or down the implement with auto-lift control switches, do not approach the implement. And before using the switches, you have to check the safety conditions of the working area.</li></ul>
--	--

## (7) Hydraulic System Diagram

### Mechanical Hydraulic Lift (MHL)

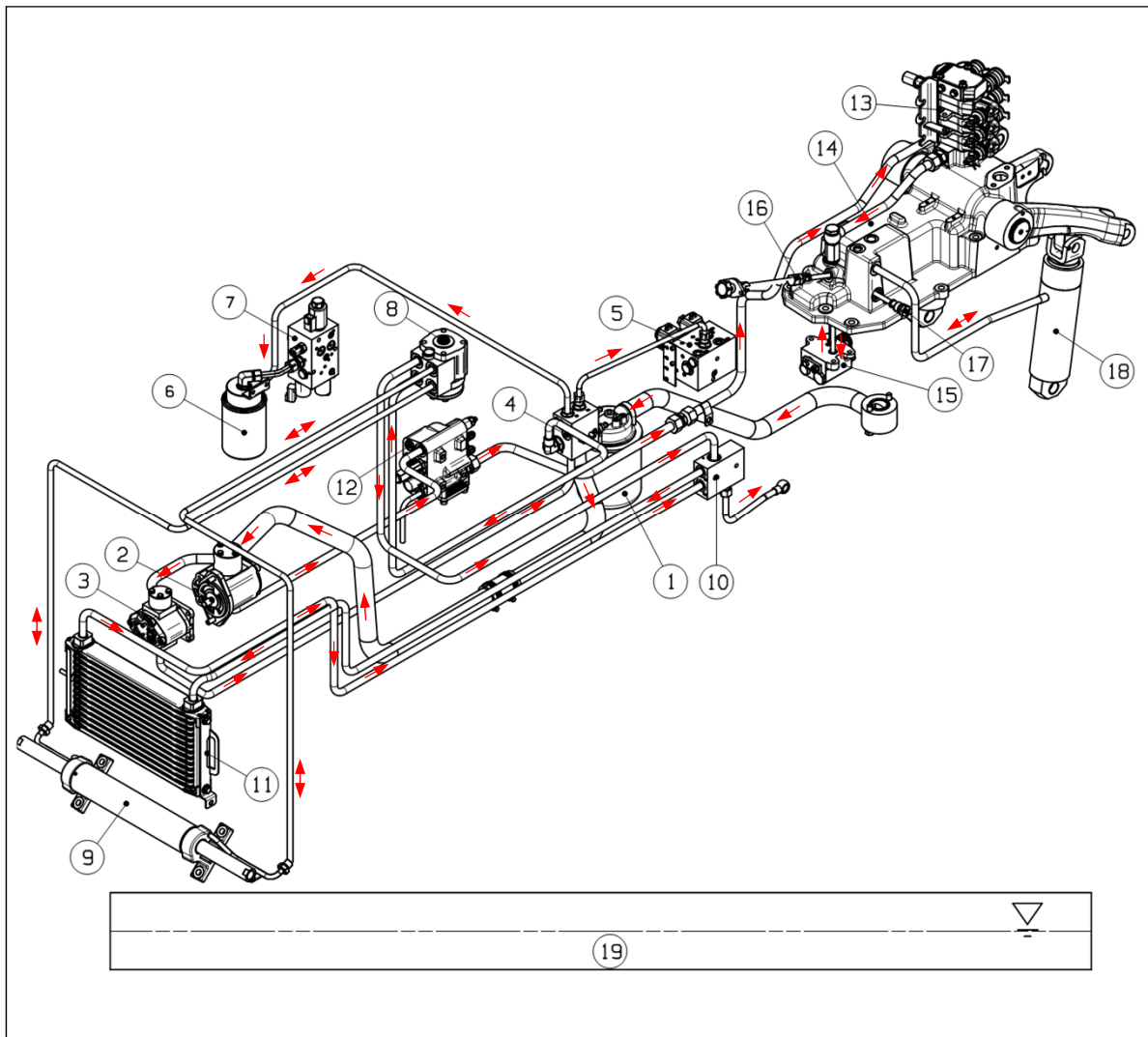

- |                                    |   |                                  |
|------------------------------------|---|----------------------------------|
| 1. Hydraulic oil filter            | 8. Steering unit  | 14. Hydraulic lift housing       |
| 2. Hydraulic lift pump             | 9. Steering cylinder                                      | 15. Hydraulic lift control valve |
| 3. Steering pump                   | 10. Oil cooler valve                                      | 16. Down speed control valve     |
| 4. Sequence valve                  | 11. Oil cooler  | 17. Safety valve                 |
| 5. TM control valve                | 12. Front loader valve /<br>Front outlet block (optional) | 18. Hydraulic lift cylinder      |
| 6. Power shuttle filter (optional) | 13. Remote control valve<br>(optional)                    | 19. Oil tank (TM case)           |
| 7. Power shuttle valve (optional)  |   |                                  |

## Electro-Hydraulic Lift (EHL, Optional)

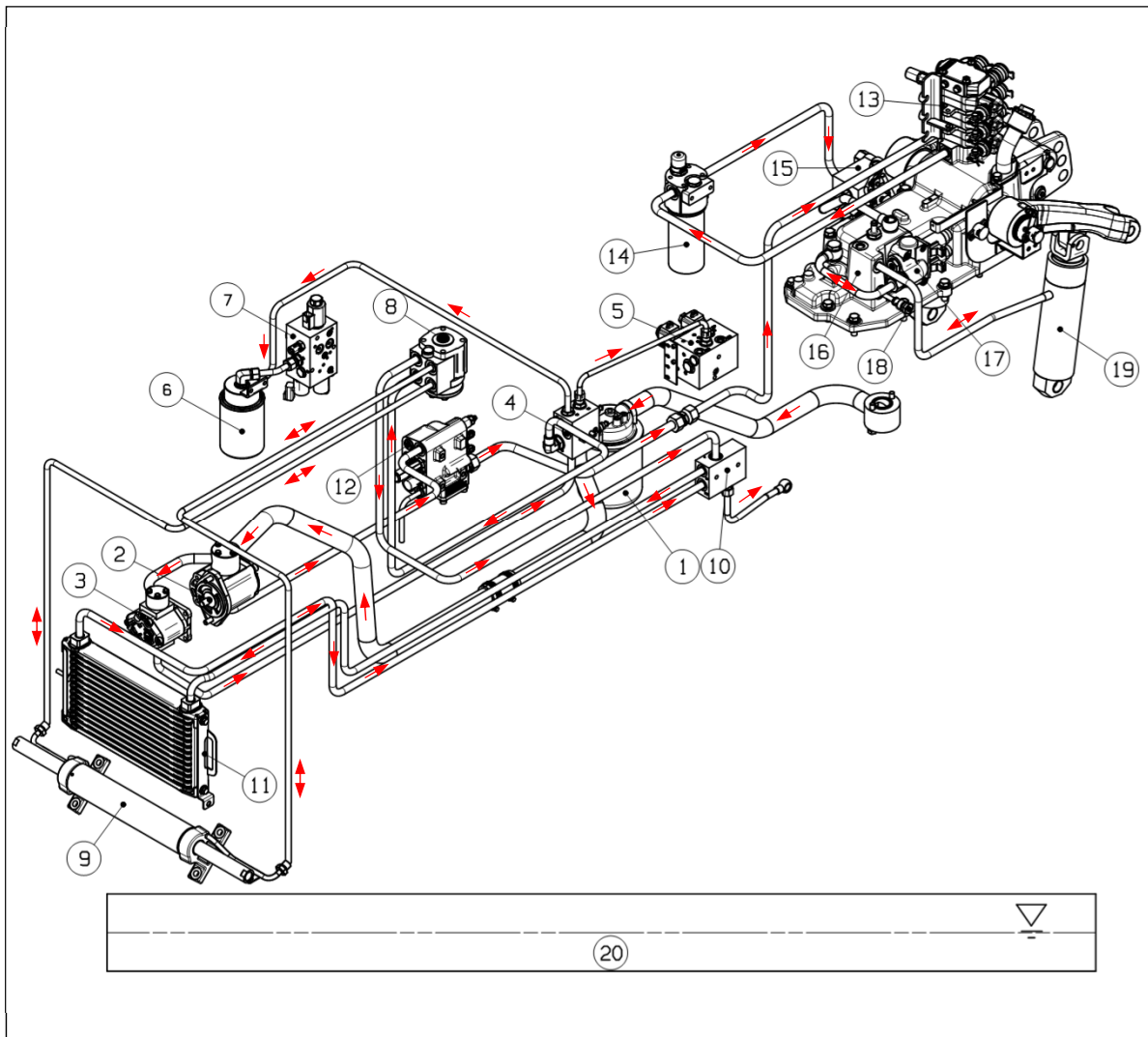

- |                                    |  |  |
|------------------------------------|--|--|
| 1. Hydraulic oil filter            | 8. Steering unit                                       | 14. In-line pressure filter (optional) |
| 2. Hydraulic lift pump             | 9. Steering cylinder                                   | 15. Leveling control valve (optional)  |
| 3. Steering pump                   | 10. Oil cooler valve                                   | 16. Hydraulic lift housing             |
| 4. Sequence valve                  | 11. Oil cooler   | 17. EHL valve                          |
| 5. TM control valve                | 12. Front loader valve / Front outlet block (optional) | 18. Safety valve                       |
| 6. Power shuttle filter (optional) | 13. Remote control valve (optional)                    | 19. Hydraulic lift cylinder            |
| 7. Power shuttle valve (optional)  |  | 20. Oil tank (TM case)                 |

## 4. Operation and Work

### 4-1. How to handle new tractor

#### (1) Check points

※ For new tractor, the followings must be checked once again even though there was sufficient quality management, inspection, regulating of each part in the factory.

- Appearance check
  - Is there any damage while transporting?
- Engine cooling system check
  - Is there anti-freeze solution in the radiator? And any leakage?
- Fuel system check
  - Is there any leakage of fuel in the fuel system?
- Oil level check
  - Is there optimal oil amount in each part ?
- Electric system check
  - Is there any cut-off or any other problem in the wiring?
  - Is there any problem to operate the instruments?
  - Is the state of battery charging sufficient?

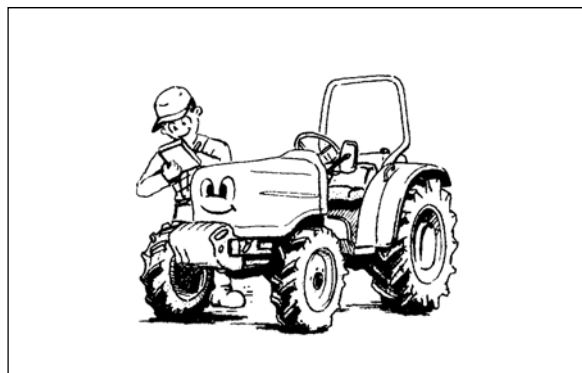

#### (2) Notices in handling new tractor (Engine brake-in procedure)





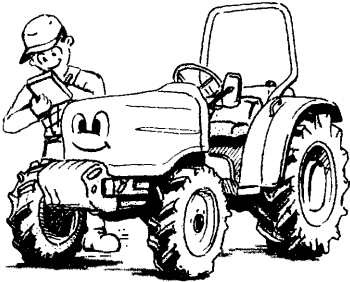

- To get the best performance, comply with the followings.
  - DO NOT start or stop the tractor suddenly.
  - DO NOT operate heavy loaded work and do not increase the engine rpm to high speed suddenly.
  - Despite warm ambient temperature, warm up the engine for about 5 minutes at low idle rpm.
  - Use the lower gear ratios when pulling heavy loads and avoid continuous operation at constant engine speeds. You will save fuel and minimize engine wear by selecting the correct gear ratio for a particular operation
  - Avoid prolonged operation at either high or low engine speeds without a load on the engine.
  - Check the instruments frequently and keep the radiator and oil reservoirs filled to recommended levels. Daily checks include the engine oil level, radiator coolant, and air cleaner.
  - After using the first 50 hours, be sure to perform the maintenance items listed in the maintenance schedule. Refer to the chapter 5-4, "First 50 hour check" in this manual. If possible, contact your authorized local dealer for "First 50 hour check".





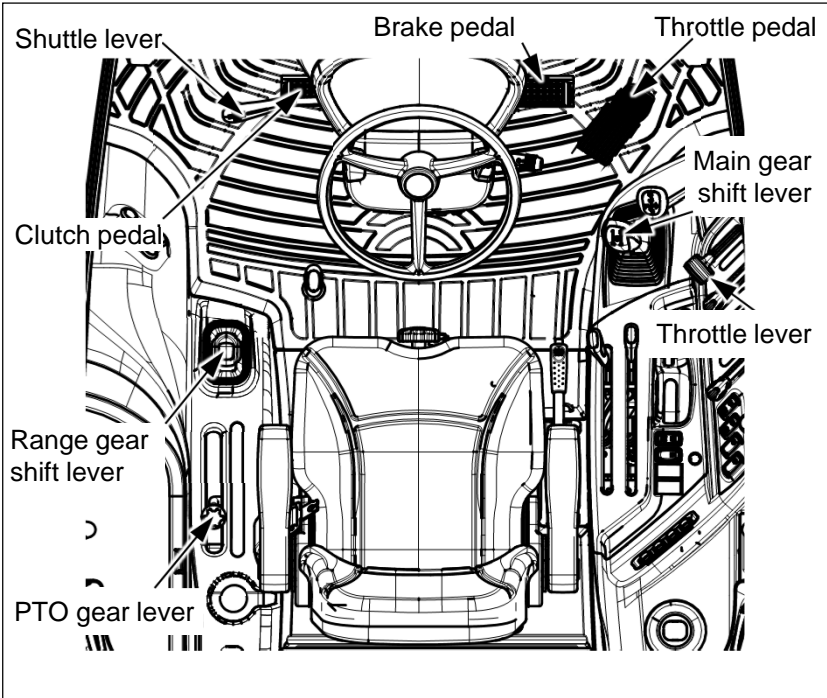
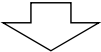
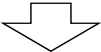

## 4-2. Engine Start and Stop

 <b>Caution</b>	<ul style="list-style-type: none"> <li>▶ Check each part before starting the engine.</li> <li>▶ Check if there is some other people around before starting.</li> <li>▶ Place all the levers and switches in NEUTRAL or OFF position.</li> </ul>	
---	---	--

### (1) Engine start

<p>1. Sit in the driver's seat and check if the parking brake is applied.</p>		<p>2. Place the main gear shift, range gear shift lever, shuttle lever in <b>NEUTRAL</b> and PTO switch in "OFF" position.</p>		<p>3. Pull the throttle lever to the low speed position.</p>
				
				
<p>4. Turn key switch to "ON" position and check if the engine oil pressure indicator, battery charging indicator and cold start aid indicator are turned on.</p>				
				
<p>5. Wait until the cold start aid indicator is turned off. (about 10 seconds)</p>				
				
<p>8. Run the engine for a few minutes to allow the engine oil and transmission oil to warm up.</p>				<p>7. Check if the engine oil pressure indicator and battery charging indicator are OFF. If any of these indicators are ON, stop the engine immediately and check the problem.</p>
<p>6. Depress clutch pedal fully and turn key switch to "START" position. As soon as the engine has been started, release the key switch to "ON" position.</p>				<p>7. Check if the engine oil pressure indicator and battery charging indicator are OFF. If any of these indicators are ON, stop the engine immediately and check the problem.</p>



 <b>Warning</b>	<ul style="list-style-type: none"> <li>▶ Only start engine outdoors or in a well ventilated place, as the engine exhaust fumes may cause sickness or death.</li> </ul>
 	<ul style="list-style-type: none"> <li>▶ To avoid an explosion, never use starting fluid to start the engine.</li> <li>▶ Start the engine ONLY from the driver's seat with depressing clutch pedal fully and placing all the transmission gear levers in neutral position.</li> <li>▶ DO NOT start the engine by shorting across the terminals of the starter motor. If the engine starts, the tractor can be moved suddenly.</li> </ul>
 <b>Caution</b>	<ul style="list-style-type: none"> <li>▶ To start the engine, be sure to depress the clutch pedal fully, place the shuttle lever in neutral position, and put PTO switch in "OFF" position. If not, the engine can not start even if turning the key switch to "START" position.</li> <li>▶ DO NOT operate the starter motor more than 10 seconds. If the engine does not start, wait for 1~2 minutes before restarting.</li> <li>▶ When the engine is running, DO NOT turn the key switch to "START" position. It may cause a failure of the starter motor.</li> <li>▶ In cold weather, be sure to warm up the engine sufficiently. If using the tractor suddenly in cold weather, the engine life can be reduced.</li> </ul> <p><b>Especially for power shuttle model, sudden start without warming-up the engine can cause damage to the power shuttle clutch and reduce it's reliability. Be sure to warm up the engine until the blink of the neutral indicator disappears on the instrument panel.</b></p>

## (2) Start in cold weather

- Pull the throttle lever to the low idle position.
- Start the engine after the cold start aid indicator is turned off according to the right table.
- If the engine runs smoothly, carry out warm-up for about 5~10 minutes at low idle position. **Especially for power shuttle model, be sure to warm up the engine until blink of the neutral indicator has disappeared on the instrument panel.**
- Use the engine oil for winter in cold weather. Refer to “Lubricants and Capacity” at the end of this manual.
- Use the diesel for winter when it is very cold weather. It is much easier to start the engine.

Coolant Temp.	Preheat time(s)
60°C (140°F)	0
40°C (104°F)	0
30°C (86°F)	0
20°C (68°F)	8
10°C (50°F)	15
0°C (32°F)	18
-10°C (14°F)	25
-20°C (-4°F)	30
-30°C (-13°F)	40

 Caution	<p>▶ <b>Safety Interlock !</b></p> <p>When the ambient temperature is lower than <b>20°C</b>, the engine speed will not be increased over 1400 rpm for about maximum 1 minute. But, it is normal operation to prevent an engine failure in cold weather.</p>
--	--

Notice	<p>▶ When storing the tractor in cold weather, the battery must be removed and stored in a cool, dry place that is not frozen away from children.</p> <p>▶ Allowing engine to idle for a long time will waste fuel and cause a build up of carbon.</p>
--------	--

## (3) Engine stop

- Place all the transmission gear levers or switches in the “NEUTRAL” or “OFF” position.
- Pull the throttle lever backward to reduce the engine speed and turn the key switch to the “OFF” position. The engine will be stopped.
- Remove the ignition key after stopping engine.

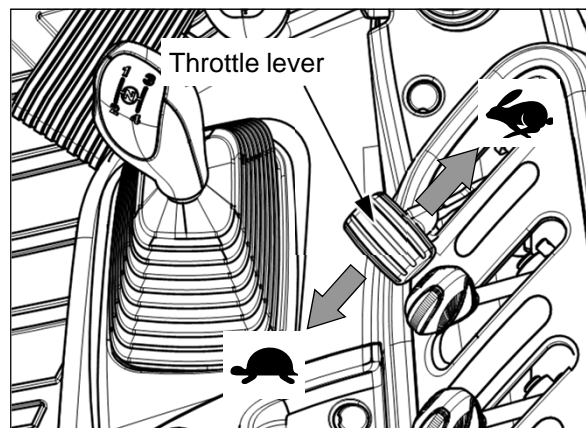

Notice	<p>▶ To stop the engine after finishing heavy work, run the engine for about 2 minutes at low idle position. If you stop the engine suddenly, the engine life could be reduced.</p>
--------	---

## 4-3. How to drive and stop

### (1) Transmission Warm-up in cold weather

The tractor hydraulic oil also serves as the tractor transmission fluid. During cold weather operation, the hydraulic oil viscosity increases. This increase in oil viscosity restricts the oil's ability to flow and lubricate in the transmission and hydraulic circuits. The cold oil can result in abnormal noises and slower operation times due to the increased oil viscosity.

**NOTE:** A warm up time at **50%** rated engine speed is recommended to assure proper vehicle functionality, transmission lubrication and operation.

**NOTE:** Do not operate the tractor under full load condition until the hydraulic oil is sufficiently warmed up.

Ambient Temperature	Recommended Warm-Up Time
Above 0 °C (32 °F)	Minimum of 5 minutes
0 – -10 °C (32 – 14 °F)	5 to 10 minutes
-10 – -20 °C (14 – -4 °F)	10 to 15 minutes
Below -20 °C (-4 °F)	More than 15 minutes

 Warning	<p>► <b>Unexpected movement!</b></p> <p><b>During the warm-up operation, do the following: Engage the parking brake, set all shift levers to their NEUTRAL positions, and place the Power Take-Off (PTO) switch in the OFF position.</b></p> <p><b>Failure to comply could result in death or serious injury.</b></p>
---	---

## (2) How to drive

### ① Synchro-shuttle model

1. Lift up all the implements (front/middle/rear) from the ground after starting engine.

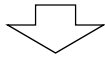

2. Pull the throttle lever to the low speed position.

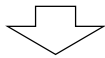

3. Depress clutch pedal fully.

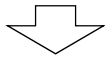

4. Place the transmission gear levers (Main, Range, Creeper, Shuttle lever) on a suitable position.

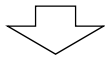

5. Press down the brake pedals and release the parking brake lever.

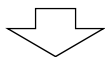

6. Release the clutch pedal slowly with pressing down the throttle pedal slowly.

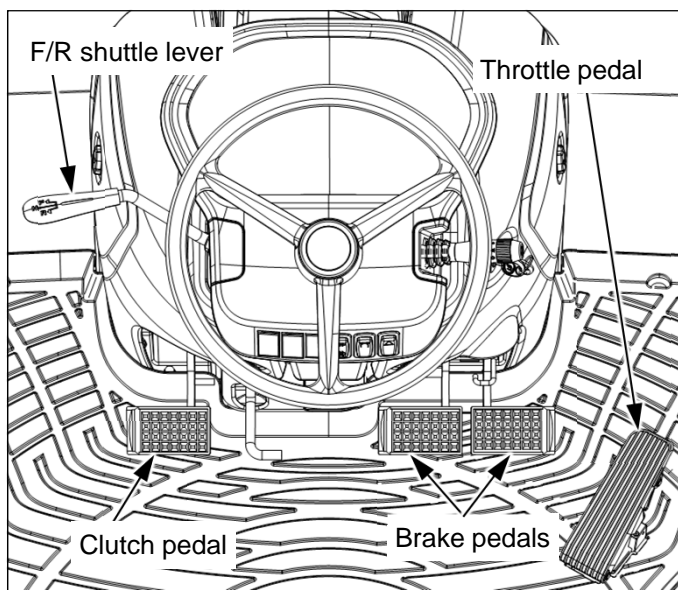
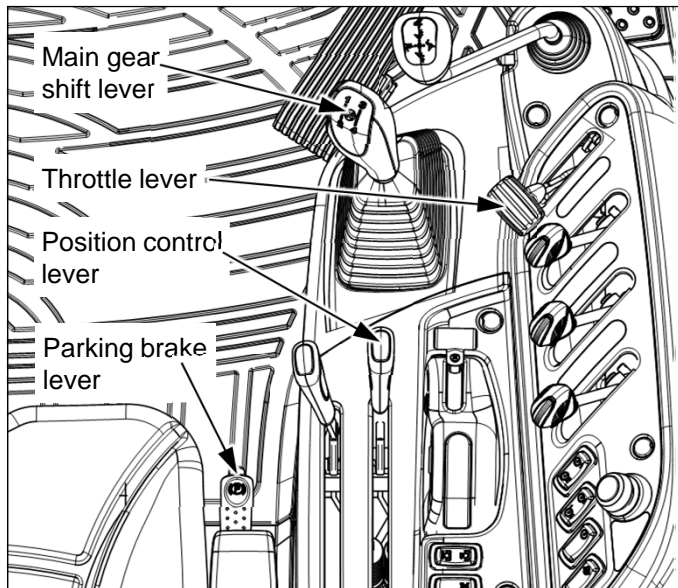

#### Notice

► Release the clutch pedal slowly. If not, the transmission gear life shall be reduced and it may cause a sudden start.

## ② Power-shuttle model

1. Lift up all the implements (front/middle/rear) from the ground after starting engine.

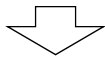

2. Pull the throttle lever to the low speed position.

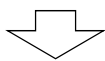

3. Place the power-shuttle lever in neutral position.

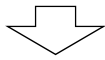

4. Place the transmission gear levers (Main, Range, Creeper gear lever) on a suitable position.

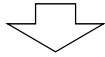

5. Press down the brake pedals and release the parking brake lever.

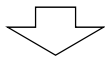

6. Place the power-shuttle lever to forward/reverse position, and press down the throttle pedal slowly when the vehicle begins to start.

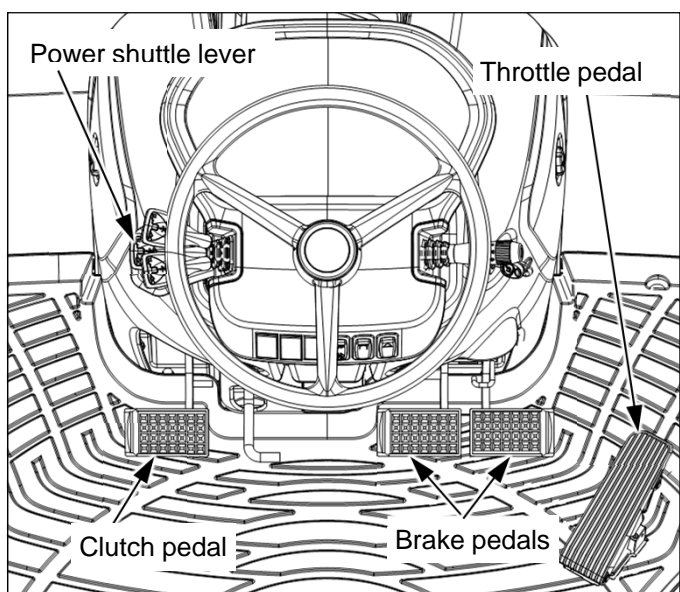
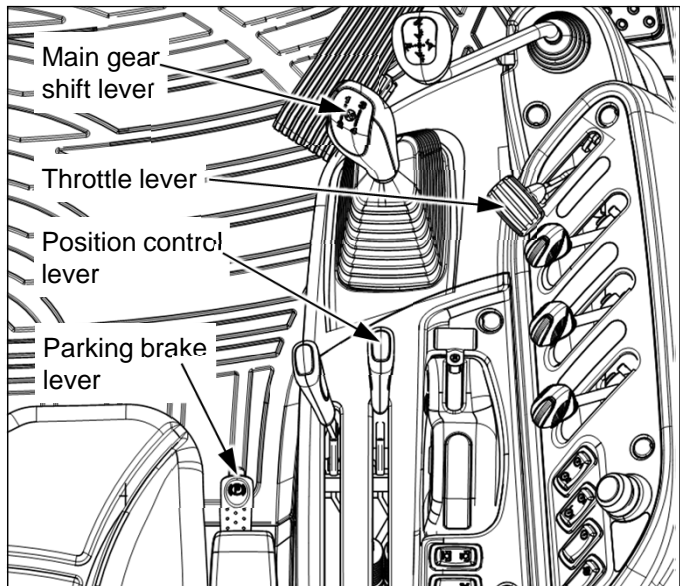

### Notice

► When starting power-shuttle model normally, use the power-shuttle lever without depressing clutch pedal.

### (3) Changing speed

- Depress the clutch pedal fully and operate all the shift levers correctly.
- Before shifting F/R Shuttle lever, range gear lever and creeper gear (if fitted), press down the brake pedals and stop the tractor completely.
- Set an appropriate driving speed according to the road conditions.

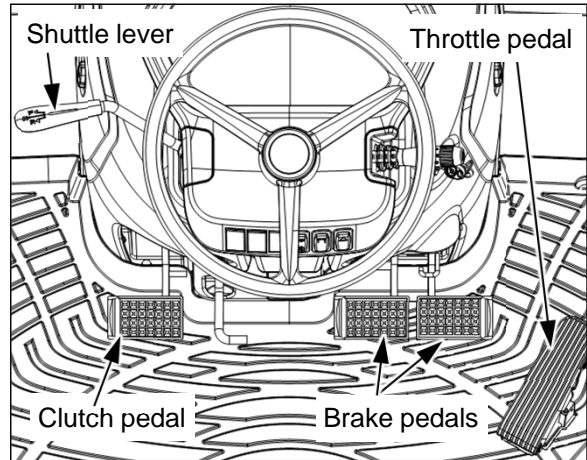

### (4) Emergency Stop

1. Press the clutch pedal and brake pedals at the same time to stop the tractor. Turn OFF the key switch.

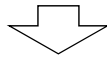

2. DO NOT release the clutch pedal until all moving parts have been stopped.

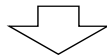

3. Apply parking brake.

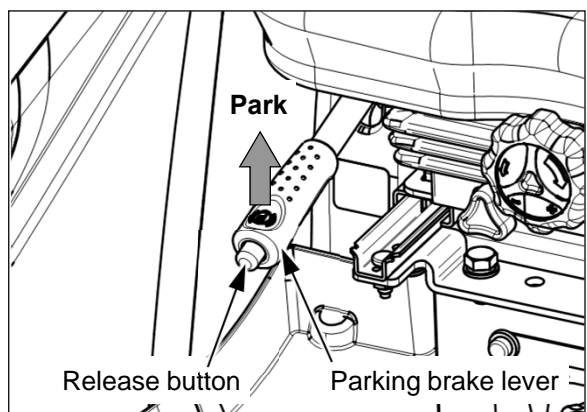
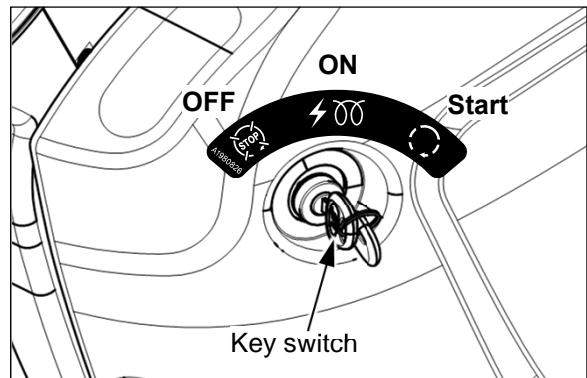

Caution

▶ DO NOT depart from the tractor with the transmission gear placed in neutral position and the parking brake is not applied. The tractor may roll down. Apply the parking brake at all times before leaving the tractor.

▶ Remove the ignition key always after stopping engine.

## (5) Stopping tractor

1. Press down the clutch pedal and brake pedals. Pull the throttle lever to "Low" speed position. Place the shuttle lever, main gear shift lever in neutral position and PTO switch to "OFF" position.

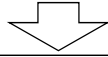

2. Lower the implements to the ground. Turn key switch to "OFF" position.

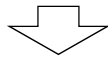

3. Apply parking brake and release the brake pedals and clutch pedal slowly.

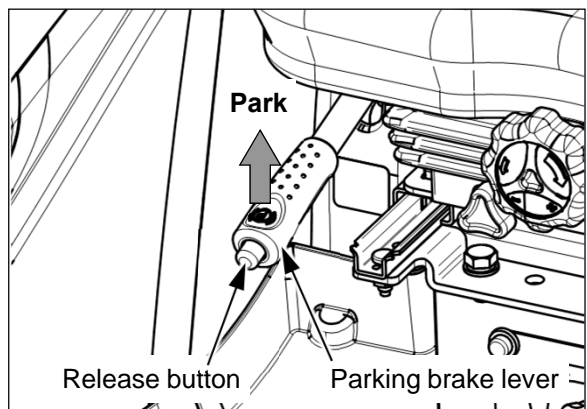
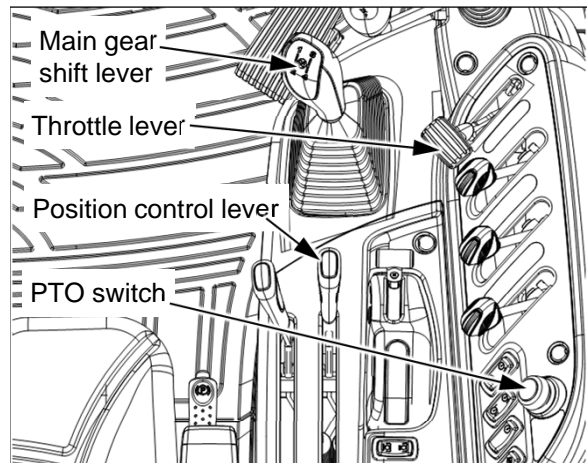
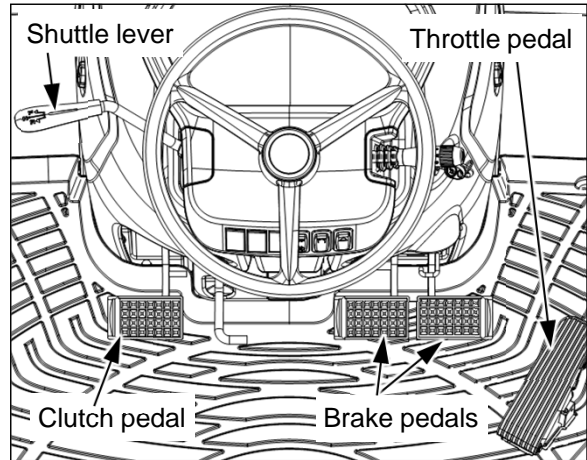



▶ DO NOT depart from the tractor with the transmission gear placed in neutral position and the parking brake is not applied. The tractor may roll down. Apply the parking brake at all times before leaving the tractor.

▶ Remove the ignition key always after stopping engine.

## (6) Parking

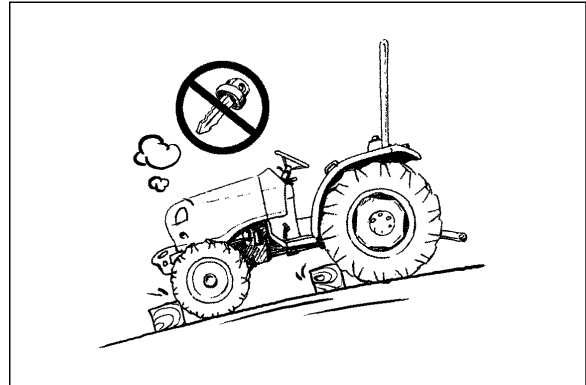
- Stop the tractor on a level surface, not on a slope.
- Disengage PTO and place all the transmission shift lever in NEUTRAL position.
- Lower the mounted implements on the ground.
- Apply the parking brake.
- Stop engine and remove ignition key.
- Before you leave the operator's station, wait for engine and all moving parts to stop.
- Apply wheel chocks to the wheels when parking the tractor on a slope unavoidably.
- **In case of the power shuttle version, to engage the low gear after the engine is stopped is NOT useful for engine brake. When parking the tractor on a hill, be sure to apply the parking brake and wheel chocks to the wheel.**



 Caution	<p>► If it is necessary to park your tractor on a slope, furthermore with a loaded trailer, the tractor may roll down, even though the parking brake is applied. In this case, apply the gear in low speed and apply wheel chocks or blocks to the all tires.</p> <ul style="list-style-type: none"><li>- <b>Mechanical:</b> downhill ⇒ reverse 1<sup>st</sup> gear / uphill ⇒ forward 1<sup>st</sup> gear.</li><li>- <b>Power shuttle:</b> Engine brakes with low speed gear is NOT available.</li></ul>
---	---

## (7) Handling Turbocharger (if fitted)

- The turbine of the turbocharger is a highly precise part that rotates at high speed.
- Before accelerating or working the tractor fitted with the turbocharger, allow the engine to idle at 1000 rpm for about 1 minute to ensure that the turbocharger is correctly lubricated.
- Before stopping engine fitted with the turbocharger, allow the engine to idle at 1000 rpm for about 2 minutes. This allows the turbocharger and manifold to cool, preventing deformation of the components.

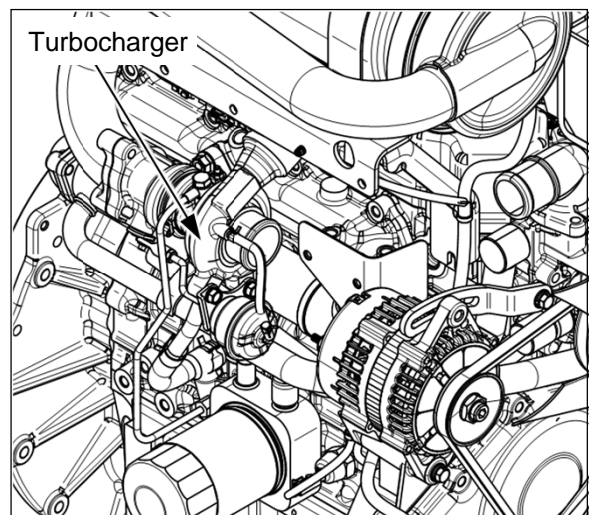



## 4-4. Transport on public roads

### (1) Safety rules when driving tractor on the roads

- When facing downhill, DO NOT place the transmission gear lever in neutral position.
- When driving the tractor on an unpaved road with a heavy rear implement on the 3-point linkage, do not drive fast and do not lift up the implement to the highest position. The hydraulic lift system may be damaged by vibration and impact. In this case, place the position control lever on the 3/4 rising position of the full stroke and select an appropriate driving speed before entering the unpaved road.

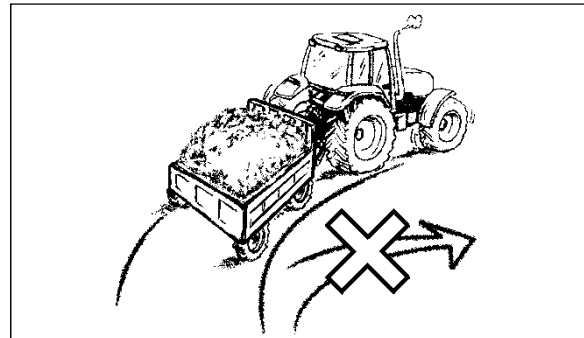
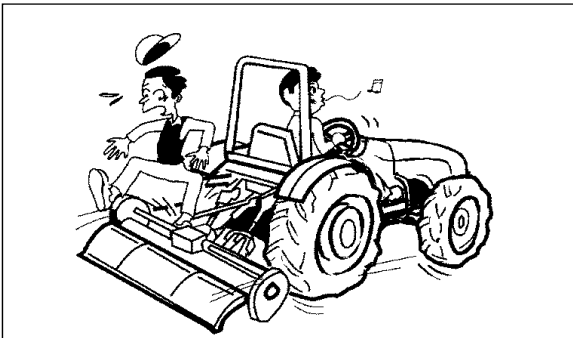
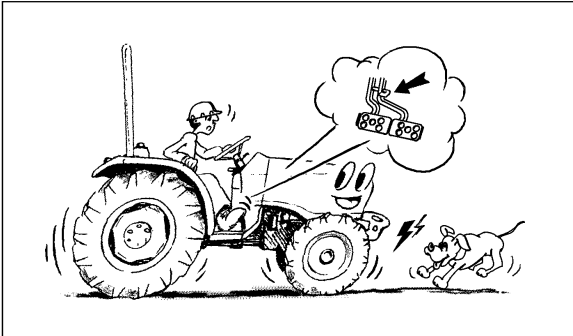

- ▶ Connect the left/right brake pedals with brake pedal latch before driving.
- ▶ Avoid a sudden start, sudden brake and sharp turning.
- ▶ DO NOT allow people on the tractor or implement.
- ▶ DO NOT place baggage on the tractor or implement.
- ▶ Place PTO gear lever in neutral position and put the PTO switch in "OFF" position.
- ▶ DO NOT use the differential lock pedal and front wheel drive(4WD) on the road.
- ▶ When traveling with an implement on the rear 3-point linkage, tighten the stabilizer to avoid lateral movement and turn the vehicle slowly with a wide turning radius.
- ▶ While traveling on public roads, do not ride your foot on the clutch pedal or brake pedals and do not operate any implement such as tiller, loader and etc.
- ▶ When starting or traveling on a slope, select a suitable main gear and range gear combination. **Specially for power shuttle models, reliability of the power shuttle clutch may be reduced rapidly due to the long engagement time.**

## (2) Light operation

### ① Cabin model

- Your tractor is equipped with the following lights.

- ① Headlights
- ② Side lights, Front turn signal lights and Hazard warning lights
- ③ Rear turn signal lights and Hazard warning lights
- ④ Tail lights and Brake lights
- ⑤ Rear work lights
- ⑥ Front work lights
- ⑦ Grille work lights

- Use the hazard warning lights and headlights (low beam) when you are traveling on public roads day or night. (North America only)
- Do not modify the lamps or change the bulb capacity arbitrarily.
- When driving the tractor on public roads, operate the lights according to your local traffic regulations.
- *For the details about light operation, refer to the chapter 3 in this manual.*

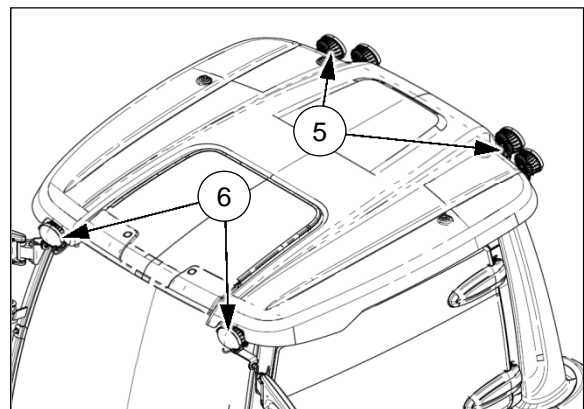
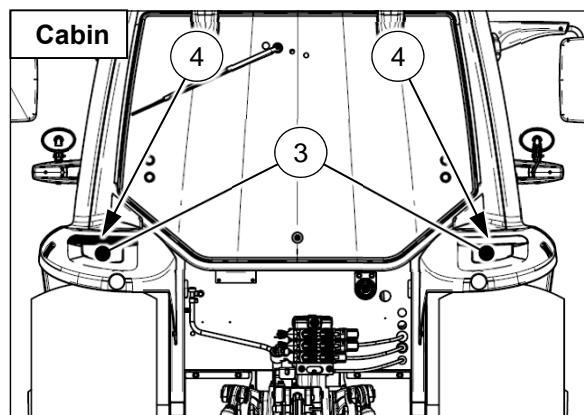
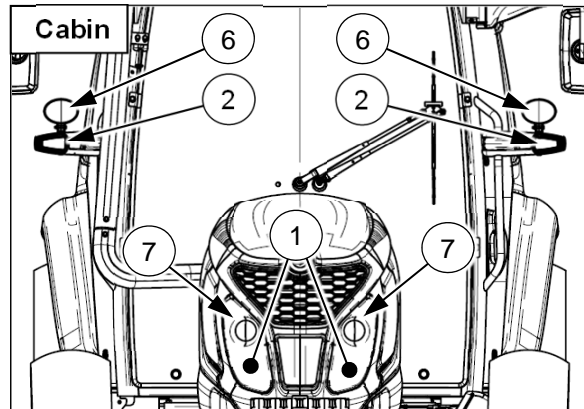

 <b>Warning</b>	<ul style="list-style-type: none"> <li>▶ Modified lamps or change bulb capacity may cause a traffic accident by disturbing approaching driver's views.</li> <li>▶ If the lamp is blown out, replace it immediately with a genuine part. In case of driving at night, it may cause a traffic accident.</li> </ul>
--	--

 <b>Caution</b>	<ul style="list-style-type: none"> <li>▶ If using the hazard warning lights for a long time while the engine is stopped, the battery can be discharged completely due to high electrical power consumption.</li> </ul>
--	--

### (3) 7-Pole connector (optional)

- One of the standard 7-pole trailer connectors is provided and is mounted at the rear of the tractor. The connections of the 7-pole connector (viewed from the rear of the tractor) are as follows;

- **ASAE Version**

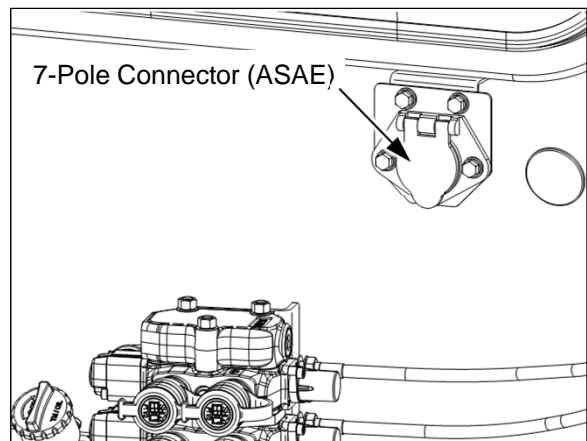
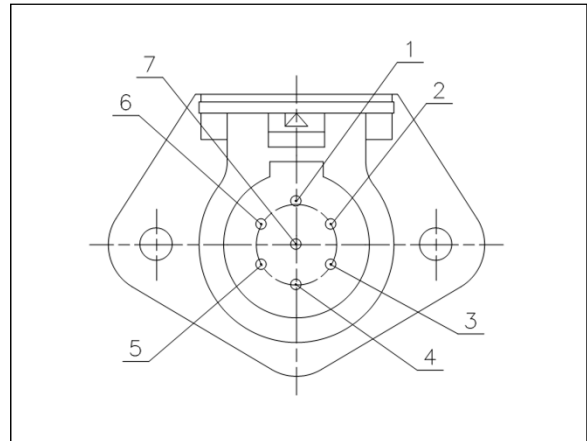

Pin No.	Function
1	Ground (Earth)
2	Working light
3	Left turn signal light
4	Brake light
5	Right turn signal light
6	License number plate light
7	Auxiliary

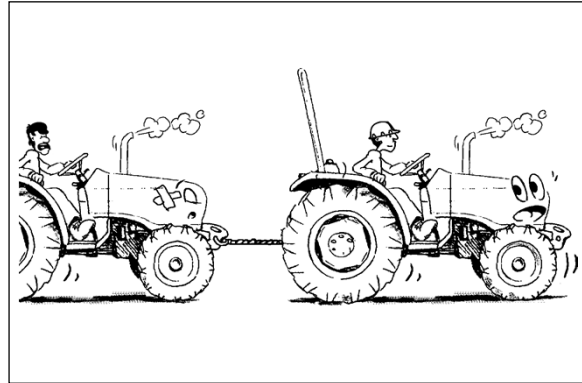

#### (4) Notices when towing the tractor

- If your tractor needs to be towed for a short distance, use the hitch (or drawbar) or front towing hook. Do not connect to other structures such as rear axle, ROPS, front axle, steering components for towing. These components could be damaged by the chain or by excessive strain.
- Your tractor can be steered for a short distance without engine running, but it will be hard to turn the steering wheel. If possible, run the engine for steering and lubrication.
- When being towed, disengage the 4WD, differential lock, parking brake and place all gear shift levers in neutral position.
- Check the horizontal and vertical permissible load of the hitch (or drawbar) before towing. The load is different with trailer brake, and stopping distance increases with speed and weight of towed loads and slope. Make sure you consider the total weight of the equipment and its load. (See chapter 4-5-(3). "Hitch and Drawbar" in this manual. )
- Drive slowly when towing extremely heavy loads.
- Do not tow trailers that are not fitted with an independent braking system.



 Warning	<p>▶ <b>Unexpected machine movement!</b></p> <p>Never attempt to start the machine by towing. The machine could start unexpectedly.</p> <p>Failure to comply could result in death or serious injury.</p>
 Warning	<p>▶ <b>Transport hazard!</b></p> <p>Do not tow the machine on public roads. Towing could cause a safety hazard for other vehicles using the roadway.</p> <p>Failure to comply could result in death or serious injury.</p>
 Warning	<p>▶ <b>Hazard to bystanders!</b></p> <p>Do not use cables or rope to tow the machine. If the cable or rope breaks or slips, it may whip back with enough force to cause serious injury. When using a chain, attach the chain with the hook's open side facing UP. If the hook slips, it will drop down instead of flying up.</p> <p>Failure to comply could result in death or serious injury.</p>
<p>Notice</p>	<p>▶ If it is necessary to tow the tractor, all gear levers must be moved to the neutral position before stopping the engine otherwise damage to transmission components may occur during towing.</p>

- Use a strong chain when towing the tractor. Tow the tractor from the rear using only the drawbar. Tow the tractor from the front using the tow pin in the front weights or front support. Have an operator steer and brake the tractor. If possible, run the engine to provide lubrication to the transmission and power steering.
- Place the transmission gearshift levers in neutral, disengaged the front wheel drive, differential lock and park brake to tow the tractor. Do not exceed 20 km/h (12 mph).

NOTE: The tractor should only be towed a short distance, such as out of a building. Do not tow on roadways or as a method of transport.

## (5) Notices when transporting the tractor

- When transporting the tractor by truck, trailer, etc., use suitable equipment or facilities to load or unload the tractor.
- Fix the tractor tightly to the vehicle with heavy-duty straps or chains.
- When fixing the rear of the tractor, use the hitch or hitch support.
- When fixing the front of the tractor, use the towing hook.
- When driving on public roads, the transporting vehicle must have signs and lights required by local regulation to avoid collision with a vehicle.

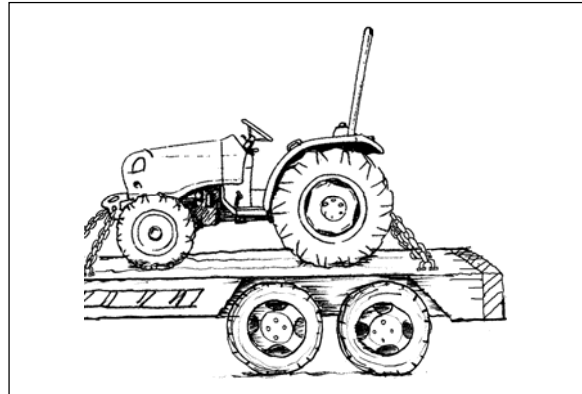

 Caution	<ul style="list-style-type: none"><li>▶ When fixing the tractor, do not hook or connect chains to the 4WD shaft, steering cylinder, tie-rod or front axle. These can be damaged by the chain or excessive strain.</li><li>▶ In case of turbocharger engine (where fitted), cover the exhaust outlet to protect that the turbocharger does not rotate by air without lubrication.</li></ul>
---	--

- Transport the tractor with all four wheels on a flatbed trailer or truck. Secure the tractor as follows:
  - Secure the front of the tractor at the front towing hook① of the front ballast weights or bumper. (optional)
  - Secure the rear of the tractor at the rear drawbar or hitch②. (optional)

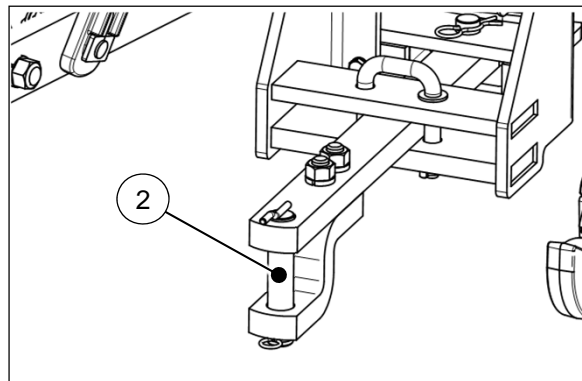
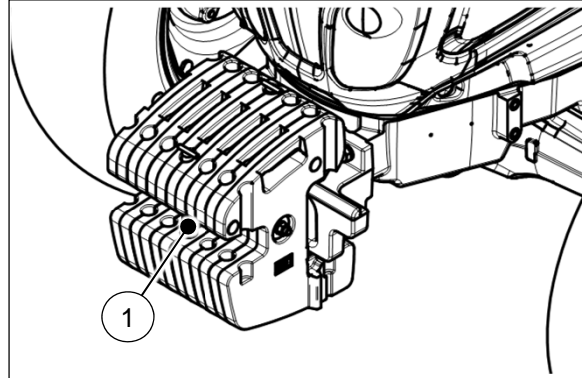

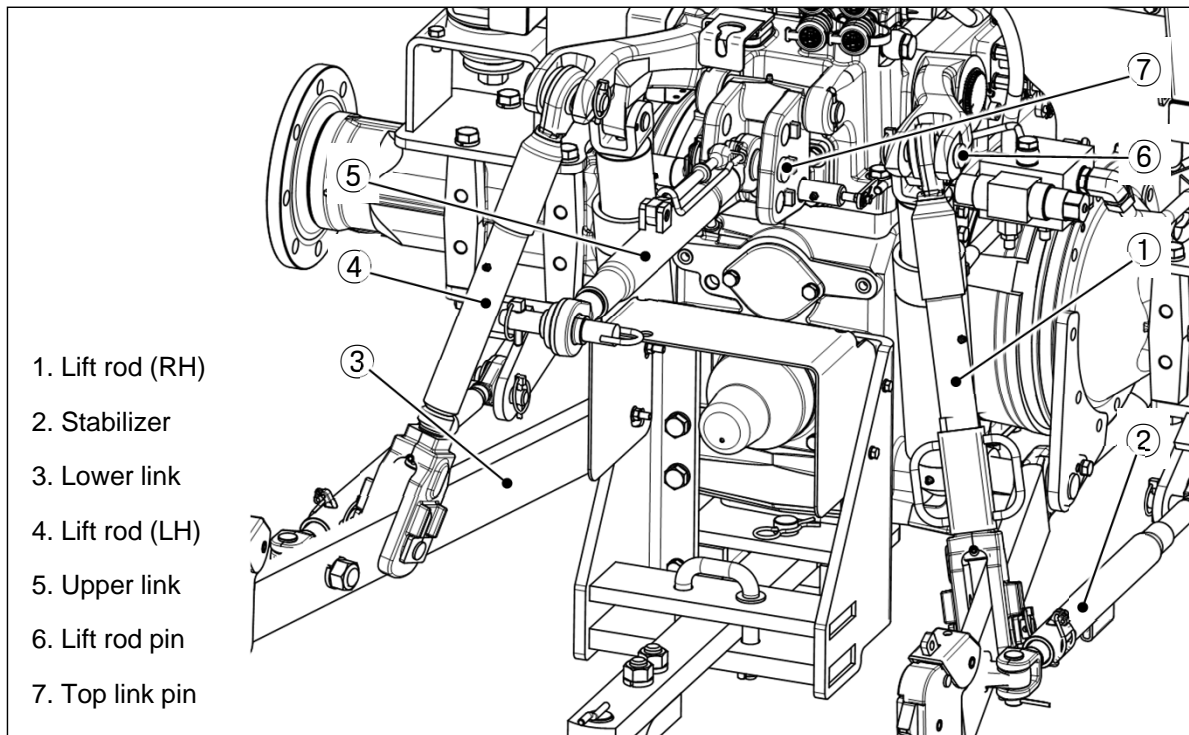

## 4-5. Field Operations

### (1) Rear 3-point linkage



- When attaching a rear implement, comply with the followings.
  1. Set the implement upright on a level surface and approach the implement in reverse.
  2. Stop the tractor on a adaptable attaching position and apply the parking brake.
  3. Connect lower link(3) to the implement and insert the lock pin firmly. (left, right)
  4. Connect upper link(5) to the implement and insert the lock pin firmly. Wide adjustable range of the upper link provides you easier attachment.
  5. Fix the implement firmly with stabilizer(2).(left, right).
  6. When detaching the implement, comply with the same procedure in reverse.

<p> <b>Warning</b></p> <p></p> <p></p>	<ul style="list-style-type: none"><li>▶ Before attaching/detaching an implement, place the PTO switch in “OFF” position and the PTO gear lever (if fitted) in neutral position, and apply the parking brake.</li><li>▶ When attaching/detaching an implement, be sure to assemble and tighten the connecting parts correctly.</li><li>▶ If your tractor is used to tow heavy loads, always use an approved drawbar or hitch to avoid a tipping, turnover and personal injury. Never connect the loads to the 3-point linkage, rear axle, or other parts.</li><li>▶ Never connect an implement that requires more power than capacity of your tractor.</li><li>▶ Never stand between implement and tractor when connecting implement.</li><li>▶ Do not change the pressure set of the relief valve arbitrarily to increase the lift capacity of the 3-point linkage. It can cause fatal damage to the hydraulic system.</li></ul>
---	--

### ① Upper link installation and adjustment

- Select a suitable attaching hole(2) depending on the implement.
- To adjust the length of the upper link, release the locking spring(3) and turn the sleeve(4) with handle(6).
- Fix the handle(6) with locking spring(3) after adjusting.
- Adjustment range : 550~855mm (21.7~33.7 in)

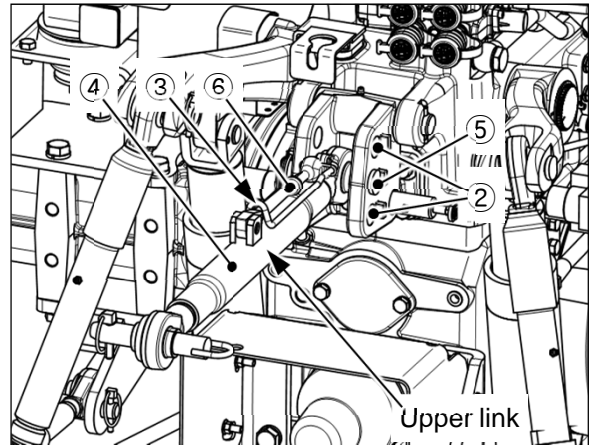

	<p><b>Caution</b> ▶ Do not adjust the length of the upper link or lift-rod over the maximum limit. It may cause fatal injury or death by falling object.</p>
--	--

### ② Adjustment of lift-rod (LH/RH)

- For lift-rod (LH), remove the upper lift-rod pin and turn the upper part of the lift rod.
- For lift-rod (RH),
  - Lift up the handle(4) and turn it to the left or right to adjust the length.
  - Lock the lift rod handle to the lower part after adjusting.

Lift rod (LH)	Lift rod (RH)
521~635 mm ( 20.5 ~ 25.0 in. )	495~635 mm ( 19.5 ~ 25.0 in. )

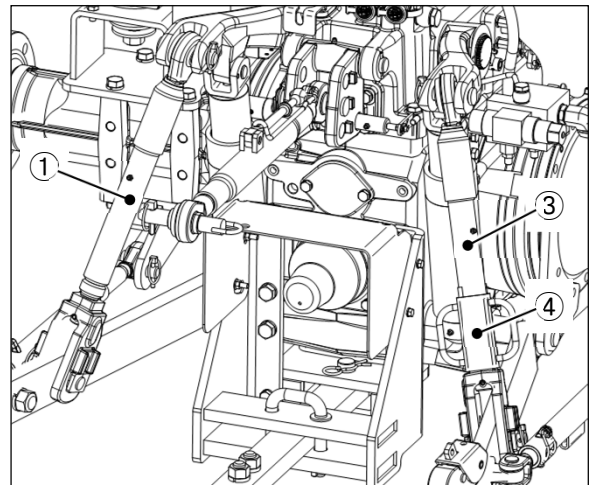

### ③ Adjustment of stabilizer (optional)

#### - Check link type

- Pull up the link pin(1) and turn the grip of the stabilizer clockwise/counter-clockwise.
- Insert the link pin(1) into the hole and let it tightened firmly by locking spring.

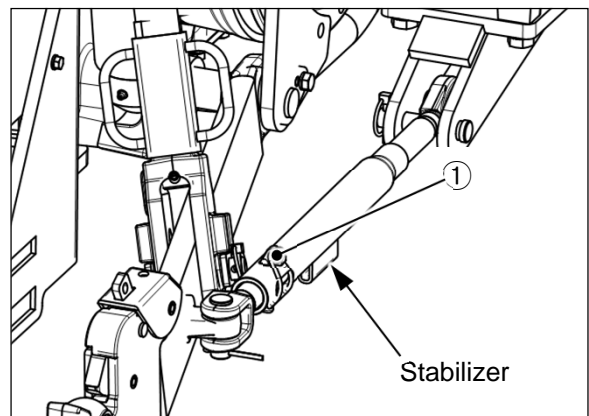

<p><b>Notice</b></p>	<p>▶ When adjusting the stabilizer's length, set the implement's lateral swinging clearance to be <b>20~40mm. (0.8~1.6 in.)</b></p>
----------------------	---



### - Telescopic link type

- Pull up the link pin(1) and turn the sleeve (2) of the check link.
- Insert the link pin(1) into the hole and let it tightened firmly by locking spring.

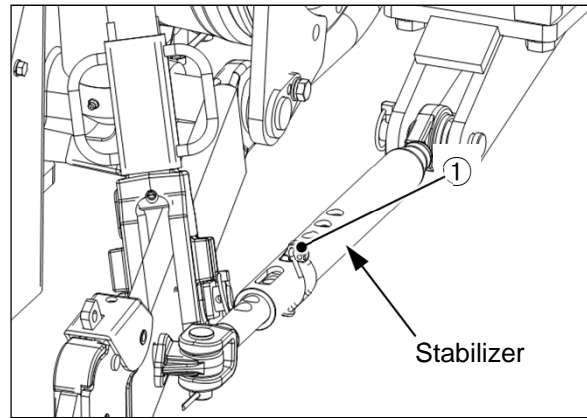

Notice	▶ When adjusting the stabilizer's length, set the implement's lateral swinging clearance to be <b>20~40mm. (0.8~1.6 in.)</b>
--------	--

### ④ Reference of implement installation part

	A	B	C (MAX)	D (MIN)	E (MAX)	F (MIN)	G	H	J	K	L	N
CAT.1	19 (0.74)	19.3 (0.75)	44 (1.73)	76 (2.99)	69 (2.71)	44.5 (1.75)	22 (0.86)	22.4 (0.88)	35 (1.38)	39 (1.53)	12 (0.47)	683 (26.8)
CAT.2	25.4 (1.00)	25.7 (1.01)	51 (2.00)	93 (3.66)	86 (3.38)	52 (2.04)	28 (1.10)	28.7 (1.12)	45 (1.77)	49 (1.92)	12 (0.47)	825 (32.4)

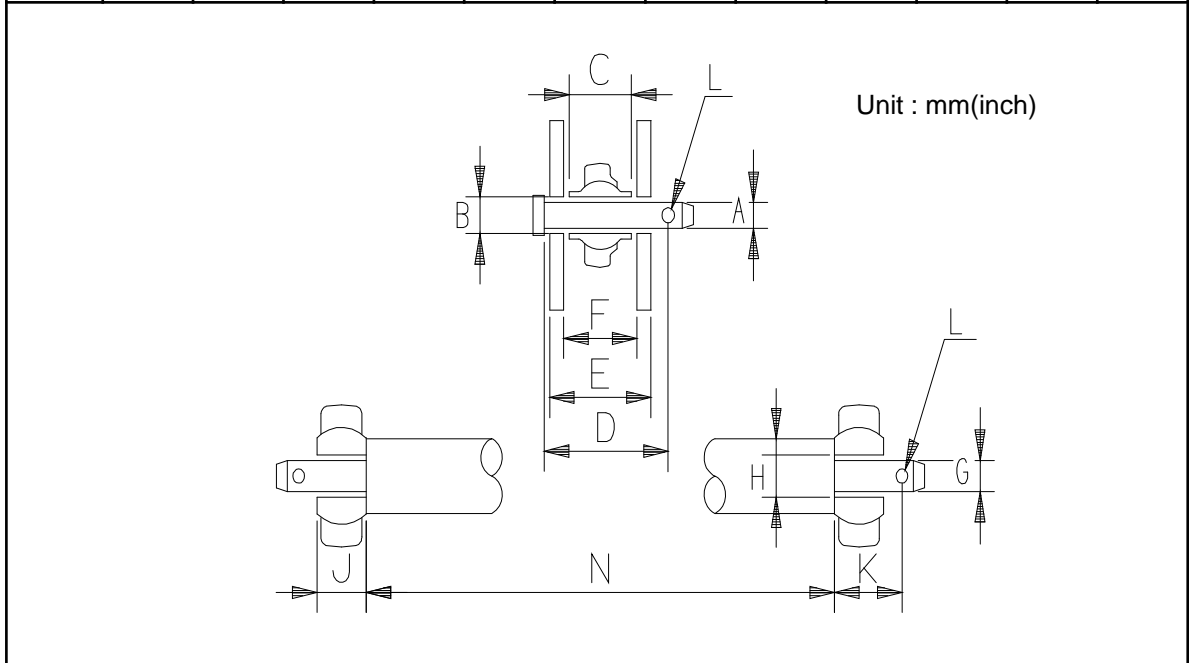

## ⑤ Handling of the 3-point linkage

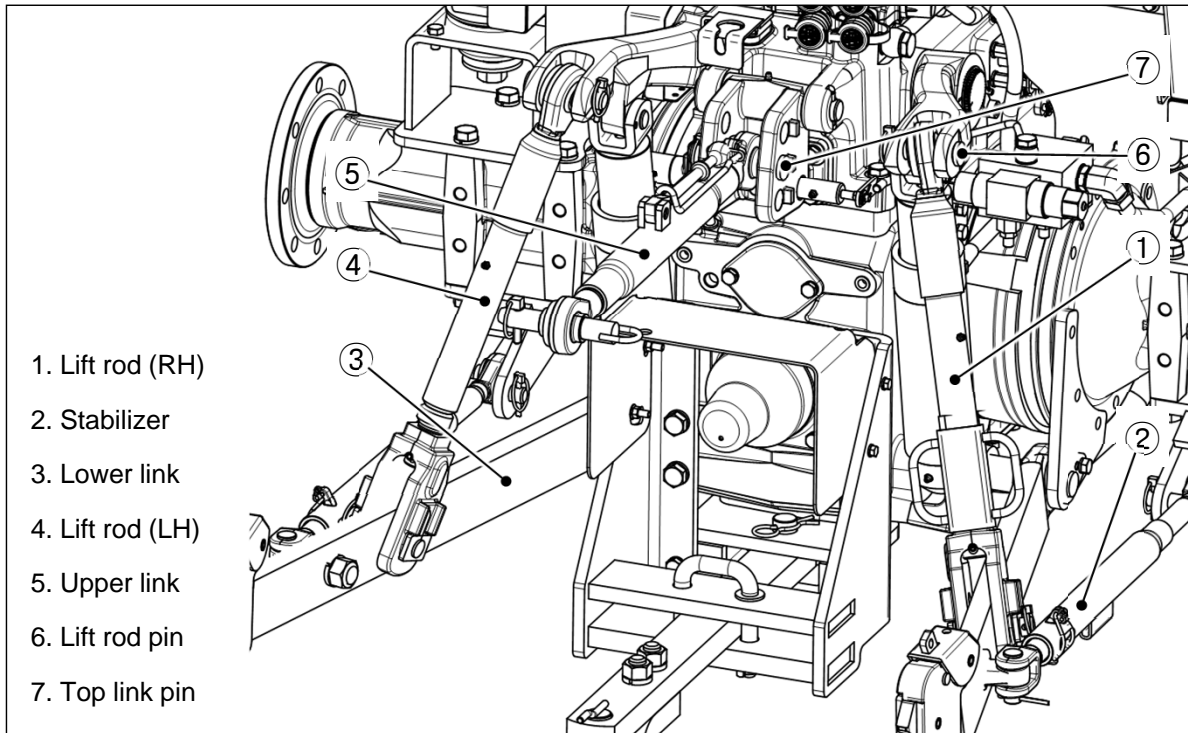

- When driving the tractor without attached implement, comply with the followings.
  1. Connect upper link(5) to the fixing hook installed in front of the upper link.
  2. Connect stabilizer(2) to the lower link(3) to avoid the lateral movement of the lower link.
- If the 3-point linkage is not necessary, remove it as follow.
  1. Remove upper link pin(7) and upper link(5).
  2. Detach rear side of the stabilizer(2) from the lower link(3) while holding lower link tightly not to fall down.
  3. Remove lift rod (LH), lift rod (RH) and stabilizer(2) step by step.
  4. Remove lower link(3) carefully not to get hurt due to its own weight.
- When using hitch/drawbar, or driving on the road, lift up the 3-point linkage and fix it by turning the down speed control knob to the locking position.

 <b>Caution</b>	<p>▶ The parts of 3-point linkage are very heavy. When handling them, take care not to get injury. PLEASE BE CAREFULL !</p>
--	---

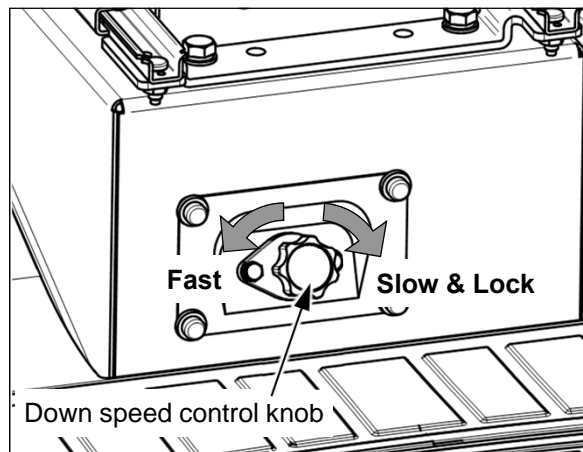



## (2) Power take-off (PTO) operation

### ① Safety precautions

- When PTO shaft is rotating, NEVER APPROACH the shaft.
- Check if PTO shield is attached correctly. If the shield is removed or damaged, replace it with a new one.
- **Suitable Clothes & Protect Entanglement :**  
When checking or attaching implement to the PTO shaft, wear tight fitting clothes and safety equipment instead of loose or long clothes. Also, slippers, high heel shoes are not suitable. Wear the suitable clothes.



 <b>Warning</b>	<p>▶ Do not approach the rotating shaft such as PTO shaft or cooling fan, especially, with loose and long clothes. The entanglement in rotating shaft can cause serious injury or death. Stop the engine and be sure to check that the PTO shaft has been stopped completely before getting near it.</p>
	

### ② Specification and Dimension of Rear PTO shaft

- Check the specification of the rear PTO shaft before attaching an implement. The spline teeth may be different depending on the market.

#### - Spline Teeth : 6T (Where fitted)

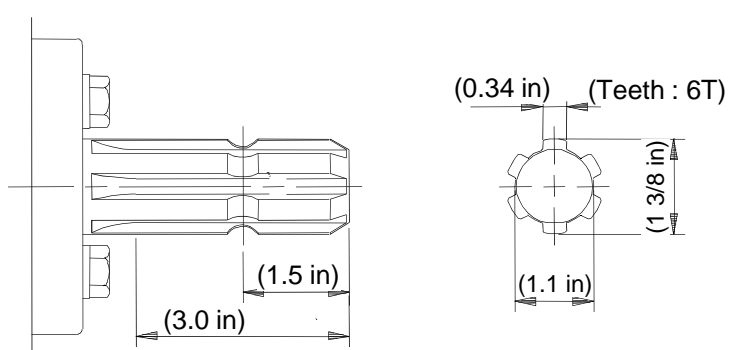
PTO gear(s)	1	2	3
PTO / Engine speed	540 / 2237 rpm	750 / 2471 rpm	1000 / 2318 rpm
Rotation direction	Clockwise (When looking at PTO shaft end)		
Shaft dimension (Unit : inch)			

### ③ Attaching power take-off(PTO) drive shaft

- When connecting PTO drive shaft to the PTO shaft and implement, make sure to check that the locking pin of the PTO drive shaft is locked in place.
- When attaching PTO drive shaft, refer to the drawings as below for safety clearance zone.
- After installing implement(s), check the followings according to the position of the 3-point linkage.
  - check the articulation angle of the PTO drive shaft and rotating noise is suitable.
  - check the interference with PTO safety cover and other structure.
  - check the effective engaging length of the PTO drive shaft.
  - check the working position of the automatic PTO ON/OFF device. (if fitted)

 Caution	<p>► The steep inclination of the PTO drive shaft makes a loud noise and cause a failure of the PTO driveline. When working in the field, do not lift up the rear implement over the manufacturer's limitation <b><i>that the maximum articulation angle of the PTO drive shaft is 18 degree when the PTO drive shaft is rotating.</i></b></p>
---	--

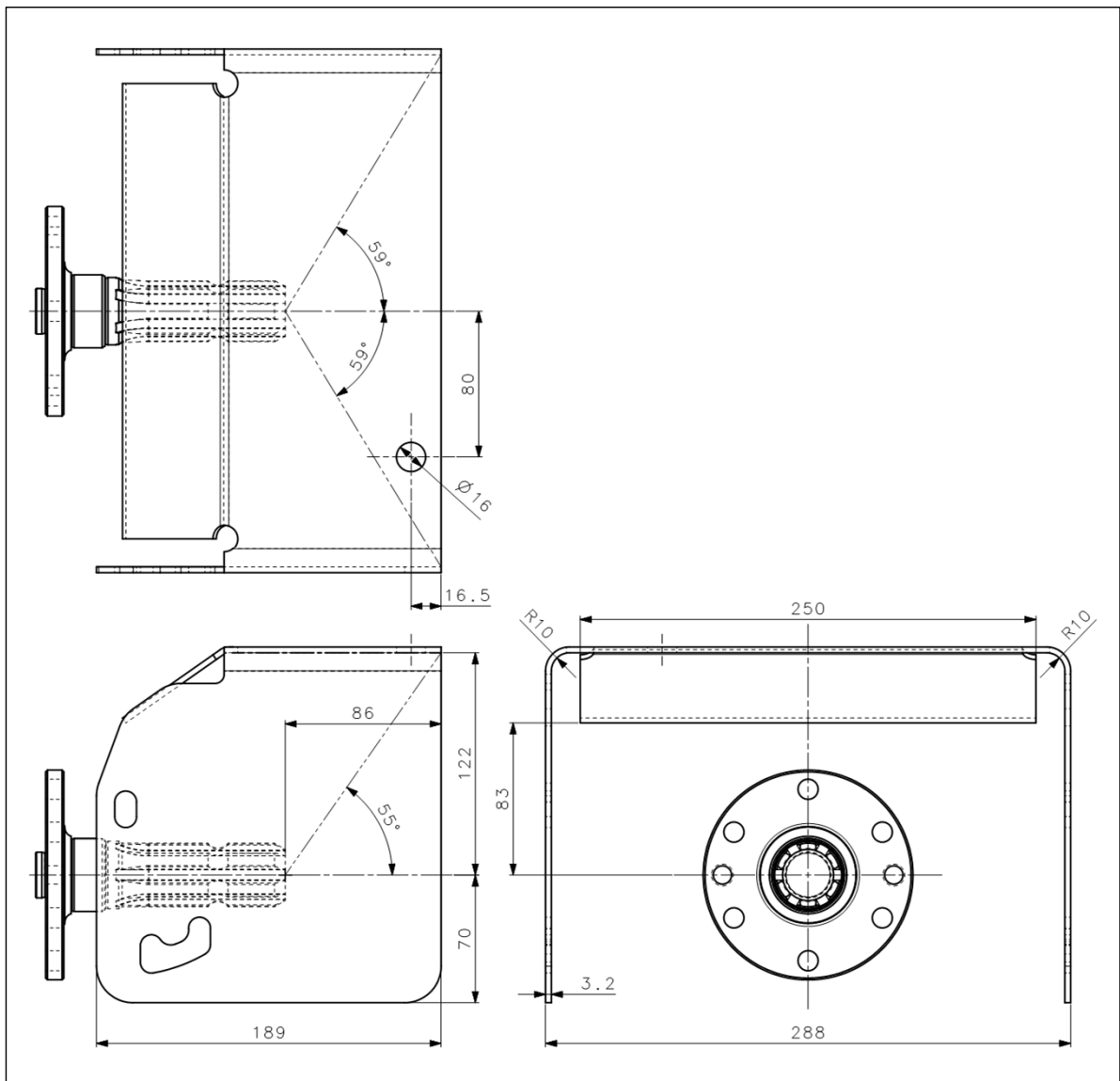



- Implements with a high power requirement should be operated with the 1000 rev/min PTO (21-spline shaft). (optional)
- When using the PTO output shaft to operate implements, it is recommended if possible that the implement is fitted with a slip clutch to avoid damage to the PTO output shaft and other tractor components.

Example of PTO drive shaft



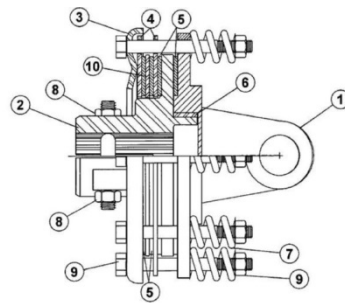

Example of slip clutch



 Caution	<p>▶ Do not engage the PTO clutch at high engine speed. Sudden engagement can cause damage to the implements, PTO clutch and drive line. Engage the PTO at low idle rpm, and then raise the engine speed up.</p>
---	--

#### ④ Changing the power take-off(PTO) shaft (optional, if provided)

 Warning	<p>Entanglement hazard !</p>
	<p>► Before attaching or detaching equipment or changing the PTO shaft:</p> <ol style="list-style-type: none"> <li>1. Apply the parking brake.</li> <li>2. Move all controls to neutral and PTO switch to “OFF” position.</li> <li>3. Stop the engine and remove the key.</li> <li>4. Wait for the PTO shaft to stop turning before leaving the driver’s station.</li> </ol> <p>Failure to comply could result in death or serious injury.</p>

 Warning	<p>► Personal Protective Equipment (PPE) required.</p> <p>When assembling, operating, or servicing the machine, wear protective clothing and PPE necessary for the particular procedure. Some PPE that may be necessary includes protective shoes, eye and/or face protection, hard hat, heavy gloves, filter mask, and hearing protection.</p> <p>Failure to comply could result in death or serious injury.</p>
---	---

- Remove the plastic protection cap.
- Using a suitable tool, unscrew the 6-M10 bolts(1) and remove the PTO shaft.
- Make sure that the 2-parallel pins are in place.
- Assemble the new PTO shaft and tighten the 6-M10 bolts(1).
- Assemble the plastic protection cap when not using the PTO shaft.
- Two splined PTO shafts are available (optional):
  1. PTO shaft with 21 splines for 1000 RPM PTO.
  2. PTO shaft with 6 splines for 540, 540E or 750 RPM PTO.

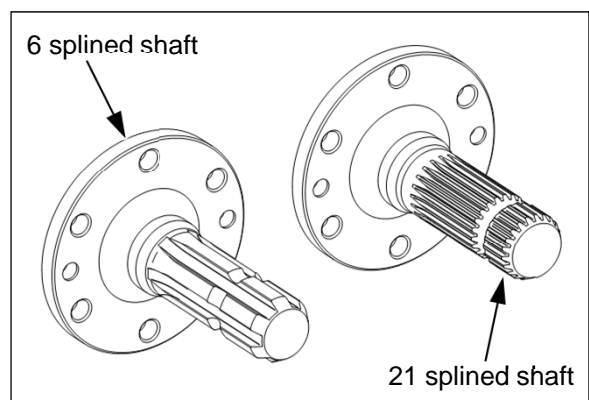
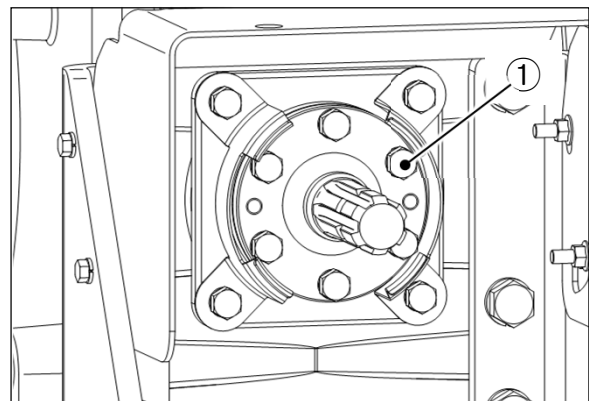

 Caution	<p>► Implements with a high power requirement should be operated with the 1000 rev/min PTO and it is obligatory to fit the PTO with 21 splines.</p>
---	---

### (3) Hitch and Drawbar (optional)

- When attaching towed equipment, use the hitch or drawbar. DO NOT use the 3-point linkage or other parts. If so, the tractor could turnover.
- When attaching/detaching towed equipment, be sure to check the pins locked in place correctly.
- DO NOT exceed the maximum permissible vertical and horizontal load of the couplings

#### ① Hitch

- Not applicable.

#### ② Drawbar (with clevis)

- It is used to tow the 2-axle equipment.
- It is available to adjust the position of the drawbar after removing lock-pin in the right figure. After adjusting, assemble the pins firmly.
- Type & EC component type-approval mark : TU-DBT / e13-00021
- Vertical load : 650kg (1433 lb)
- Horizontal load : 6000kg (13228 lb)

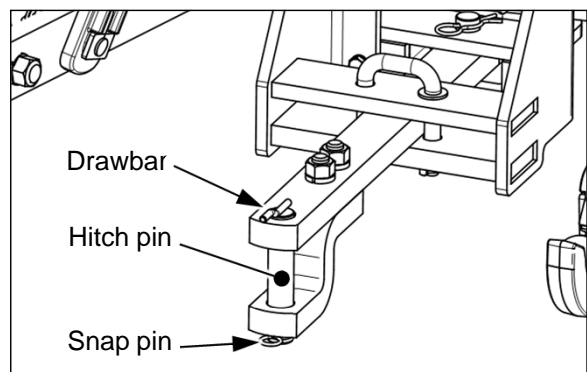

#### ③ Technically permissible maximum towable mass(es)

- The maximum permissible towable mass is depending on the brake system type on the towed equipment as below. Check the brake system of your towed equipment.

	Hitch	Drawbar
Unbraked towable mass	N/A	N/A
Inertia-braked towable mass	N/A	6000kg (13228 lb)
Hydraulic & Pneumatic braked towable mass	N/A	6000kg (13228 lb)

 <b>Caution</b>	<ul style="list-style-type: none"> <li>▶ Use always the drawbar or hitch for pulling work. DO NOT use the 3-point linkage, rear axle or other parts. If so, the tractor could be overturned.</li> <li>▶ When attaching/detaching towed equipment, apply the parking brake and stop the engine before applying the locking pins manually.</li> <li>▶ Before transporting equipment on public roads, make sure you comply with your local traffic regulation.</li> </ul>
--	--

#### (4) Technically maximum permissible mass

- When working with a front-end loader or a rear heavy loaded attachment installed to the 3-point linkage, install the ballast weights on the counter-part axle to maintain front and rear weight balance of the tractor. If not, the front or rear axle can be strained and damaged by the overloaded weight.
- When working with a front-end loader, place the attached rear weight to the highest position and turn the down speed control knob to the “**Lock**” position.
- **DO NOT exceed the total maximum permissible mass and/or permissible maximum mass on each axle** declared by manufacturer as below, even if the load capacity of the tire is sufficient.
- **If the load capacity of the tires is lower than maximum permissible mass on each axle**, the maximum mass on each axle must be loaded **under the load capacity of the tire. Check the load capacity of the tires.**

	All models	Remarks
Technically total maximum permissible mass	5400kg (11905 lb)	It may depend on the load capacity of the tires. (See next chapter)
Front axle (*)	2200kg (4850 lb)	
Rear axle	3300kg (7275 lb)	

\* includes front mounted equipment or loader in the raised position but without load in the bucket.

- **Restrict operation:** In case that driving speed of the tractor does not exceed 8km/h (5 mph) and standard front/rear wheel tracks (*refer to the chapter 4-5-(6), “Adjusting wheel track and tire replacement” in this manual*) are applied, the intermittent maximum permissible load of the front axle can be **3300kg (7275 lb)** for all models. But, it is restricted by the load capacity of the tires.

 <b>Caution</b>	<ul style="list-style-type: none"> <li>▶ Maximum permissible mass is measured with only the front or rear wheels on the scales inclusive of ballasts and with mounted equipment in the raised position.</li> <li>▶ <b>Do not exceed the maximum permissible mass above and/or the load capacity of the tires.</b> Overloaded operation may invalidate the warranty.</li> <li>▶ <b>DO NOT</b> change the setting pressure of the relief valve arbitrarily to increase the lift capacity of the front loader or 3-point linkage. It can cause fatal damage to the hydraulic system and front axle.</li> </ul>
--	---



## (5) Tires and Load capacity

- For safe operation and secure the reliability of the driveline, use only approved tire combination and manage the specified tire air pressure regularly as below table. If using an unapproved tire combination or unsuitable tire air pressure, it may cause failure of the front/rear axle and reduce the reliability of the driveline.

Axle No. (*)	Tires	Standard air pressure (kg/cm <sup>2</sup> )	Load rating per tire (kg)	Max. mass per axle (kg)	Maximum mass (kg)
1	11.2-24 8PR 115 A6	2.4 (240 KPa, 34 psi)	1215 (2679 lb)	1940 (4277 lb)	5240 (11552 lb)
2	16.9-30 8PR 136 A6	1.6 (160 KPa, 23 psi)	2240 (4938 lb)	3300 (7275 lb)	
1	9.5-24 6PR 105 A6	2.2 (220 KPa, 32 psi)	925 (2039 lb)	1480 (3263 lb)	4520 (9965 lb)
2	14.9-30 8PR 130 A6	1.8 (180 KPa, 25 psi)	1900 (4189 lb)	3040 (6702 lb)	
1	420/65R20 125 A8	1.4 (140 KPa, 20 psi)	1650 (3638 lb)	2200 (4850 lb)	5400 (11905 lb)
2	16.9 R30 137 A8	2.4 (240 KPa, 35 psi)	2300 (5071 lb)	3300 (7275 lb)	
1	420/65R20 125 A8	1.4 (140 KPa, 20 psi)	1650 (3638 lb)	2200 (4850 lb)	5400 (11905 lb)
2	540/65R30 143 D	1.6 (160 KPa, 23 psi)	2725 (6008 lb)	3300 (7275 lb)	
1	320/70R20 123 B	2.4 (240 KPa, 35 psi)	1550 (3417 lb)	2200 (4850 lb)	5400 (11905 lb)
2	420/70R30 134 B	1.6 (160 KPa, 23 psi)	2120 (4674 lb)	3300 (7275 lb)	
1	320/85R20 119 B	1.6 (160 KPa, 23 psi)	1360 (2998 lb)	2200 (4850 lb)	5400 (11905 lb)
2	420/85R30 140 B	1.6 (160 KPa, 23 psi)	2500 (5512 lb)	3300 (7275 lb)	
1	320/85R20 119 A8	1.6 (160 KPa, 23 psi)	1360 (2998 lb)	2200 (4850 lb)	5400 (11905 lb)
2	380/85R30 135 A8	1.6 (160 KPa, 23 psi)	2180 (4806 lb)	3300 (7275 lb)	
1	360/70R20 129 A8	2.4 (240 KPa, 35 psi)	1850 (4079 lb)	2200 (4850 lb)	5400 (11905 lb)
2	420/70R30 134 A8	1.6 (160 KPa, 23 psi)	2120 (4674 lb)	3300 (7275 lb)	
1	420/65R20 125 A8	1.4 (140 KPa, 20 psi)	1650(3637 lb)	2200 (4850 lb)	5400 (11905 lb)
2	VF 540/65R30 158 D	2.0 (200 KPa, 29 psi)	4250(6369 lb)	3300 (7275 lb)	
1	320/70R20 113 A8	1.6 (160 KPa, 23 psi)	1150(2535 lb)	2200 (4850 lb)	5400 (11905 lb)
2	420/70R28 133 A8	1.6 (160 KPa, 23 psi)	2060(4541 lb)	3300 (7275 lb)	
1	320/70R24 116 A8	1.6 (160 KPa, 23 psi)	1250(2755 lb)	2200 (4850 lb)	5400 (11905 lb)
2	480/70R30 141 A8	1.6 (160 KPa, 23 psi)	2575(5676 lb)	3300 (7275 lb)	

(\*) 1 : Front axle, 2 : Rear axle

 <b>Caution</b>	<ul style="list-style-type: none"> <li>▶ <b>Do not exceed the maximum permissible mass(Total/Front/Rear) declared by manufacturer.</b> Overloaded operation may invalidate the warranty. For further information, refer to the chapter 4-5-(4) in this manual.</li> <li>▶ If the front/rear tires have enough load capacity, the permissible mass on each axle can be restricted by the maximum permissible mass of the front/rear axle.</li> </ul>
--	---

## (6) Adjusting wheel track and tire replacement

- If the front wheel track is adjusted, check the clearances between tires and tractor body case by case. If necessary, the steering angle must be adjusted.  
(refer to the chapter 4-5-(8) "Adjusting steering angle" in this manual.)
- When adjusting rear wheel track, check the radial and lateral clearance between rear tire and tractor chassis as below.
  - **A : 60mm (2.4 in) (Minimum)**
  - **B : 40mm (1.6 in) (Minimum)**
- Depending on rim or disk type, the front and rear wheel tracks may vary. For the details, contact your authorized local dealer.

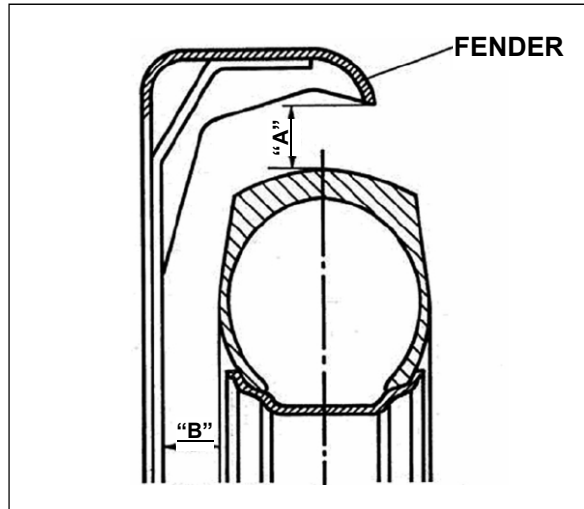

### ① Front wheel track

- 9.5-24 6PR with rim & disk (W8x24)
- 11.2-24 8PR with rim & disk (W10x24)

### ② Rear wheel track

- 14.9-30 8PR with rim & disk (W12x30)
- 16.9-30 8PR with rim & disk (W15x30)

 <p>Warning</p>	<ul style="list-style-type: none"> <li>▶ The tractor wheels are very heavy. PLEASE BE CAREFUL.</li> <li>▶ When removing the wheels, proceed with extreme caution, use a suitable hoist and specific equipment to move the heavy parts.</li> </ul>
<p>Notice</p>	<ul style="list-style-type: none"> <li>▶ When adjusting the wheel track, pay attention to the direction of tire lugs. For agricultural tires, if it shows "Λ" shape when looked behind, it is correct.</li> <li>▶ <b>Actual settings may vary depending on the brand of the rim and type of tire.</b></li> </ul>

① Front wheel track – 9.5-24 6PR with rim & disk (W8x24)

Unit : mm (inch)

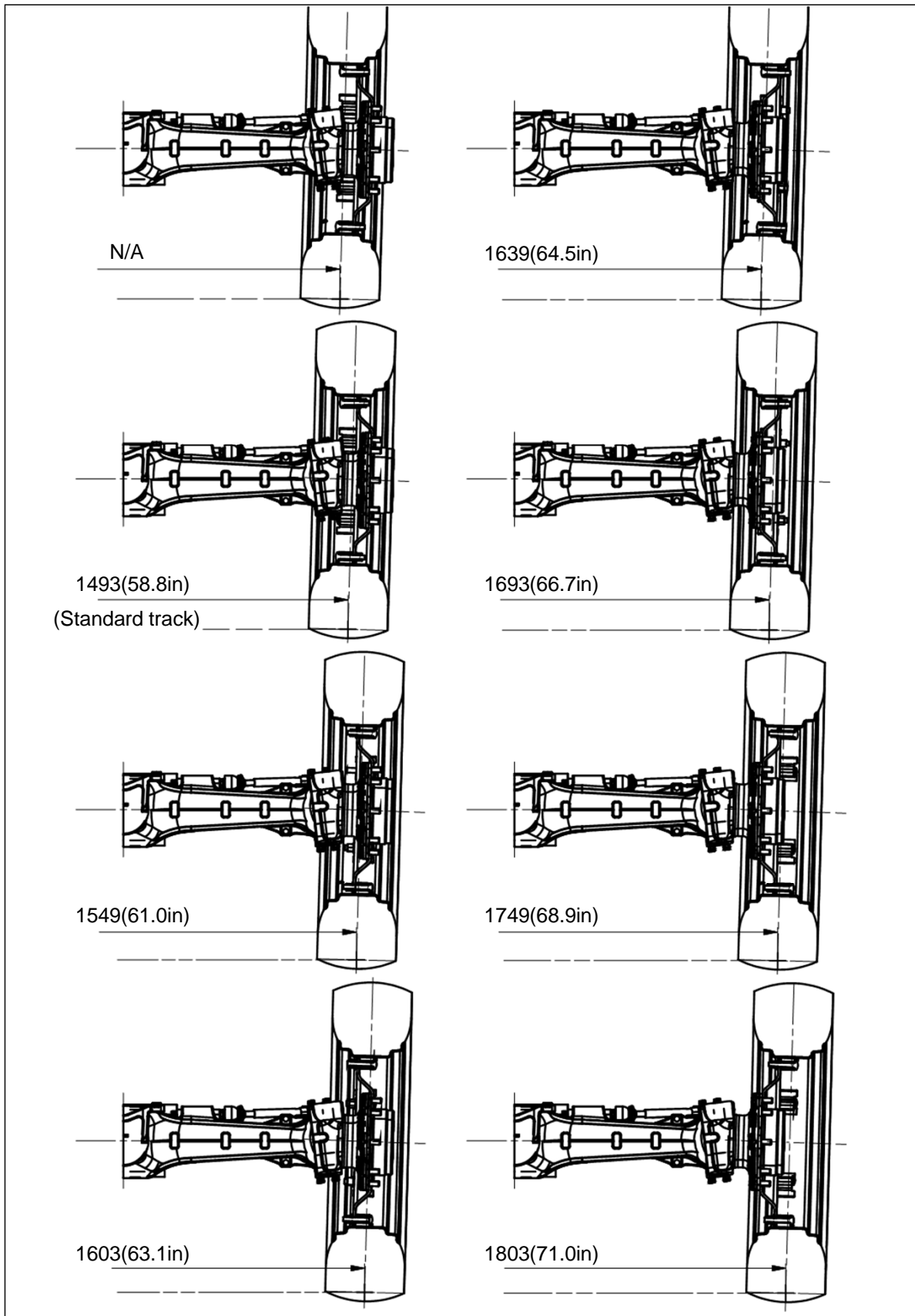

② Front wheel track – 11.2-24 8PR with rim & disk (W10x24)

Unit : mm (inch)

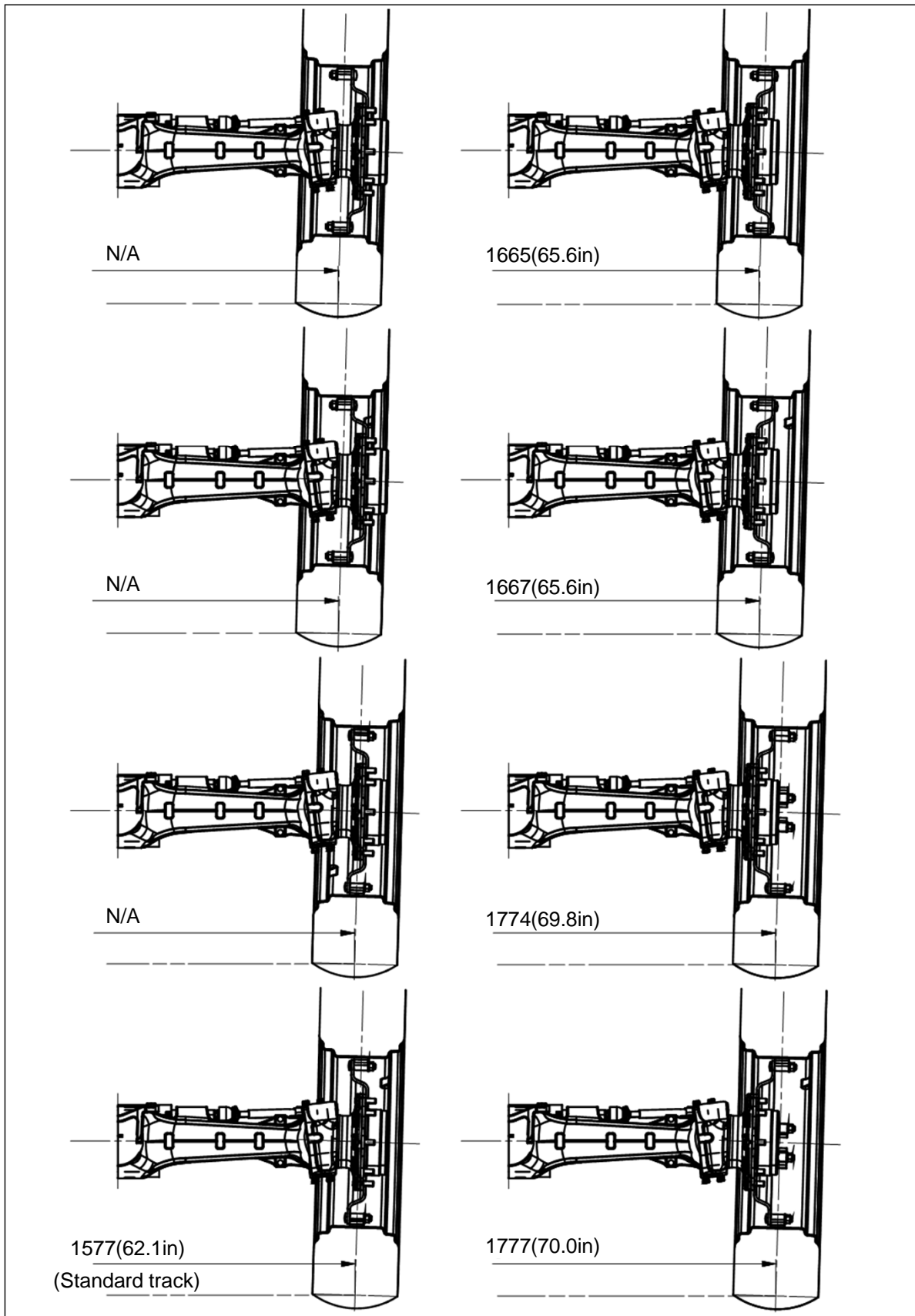

③ Rear wheel track – 14.9-30 8PR with rim & disk(W12x30)

Unit : mm (inch)

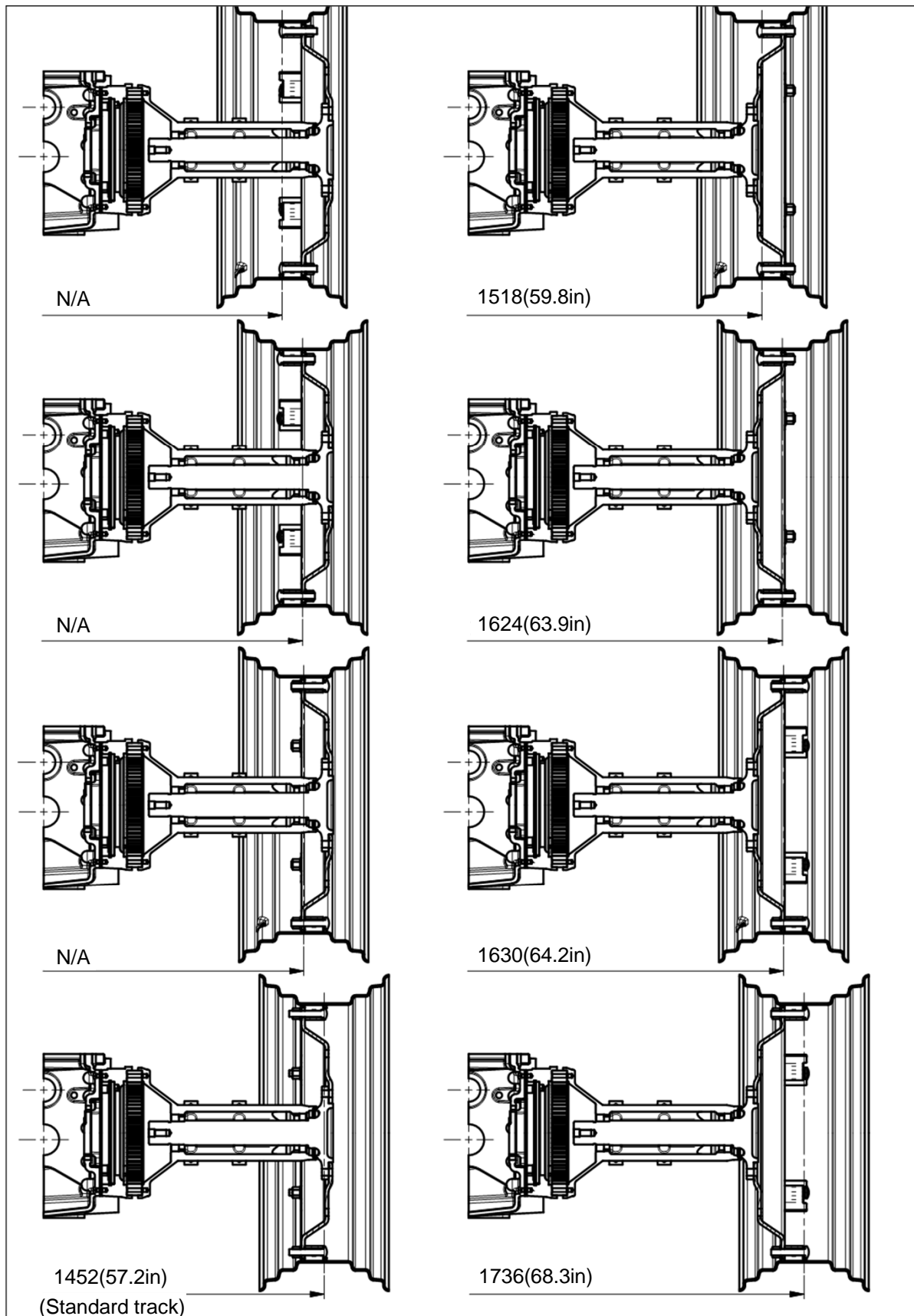

④ Rear wheel track – 16.9-30 8PR with rim & disk(W15x30)

Unit : mm (inch)

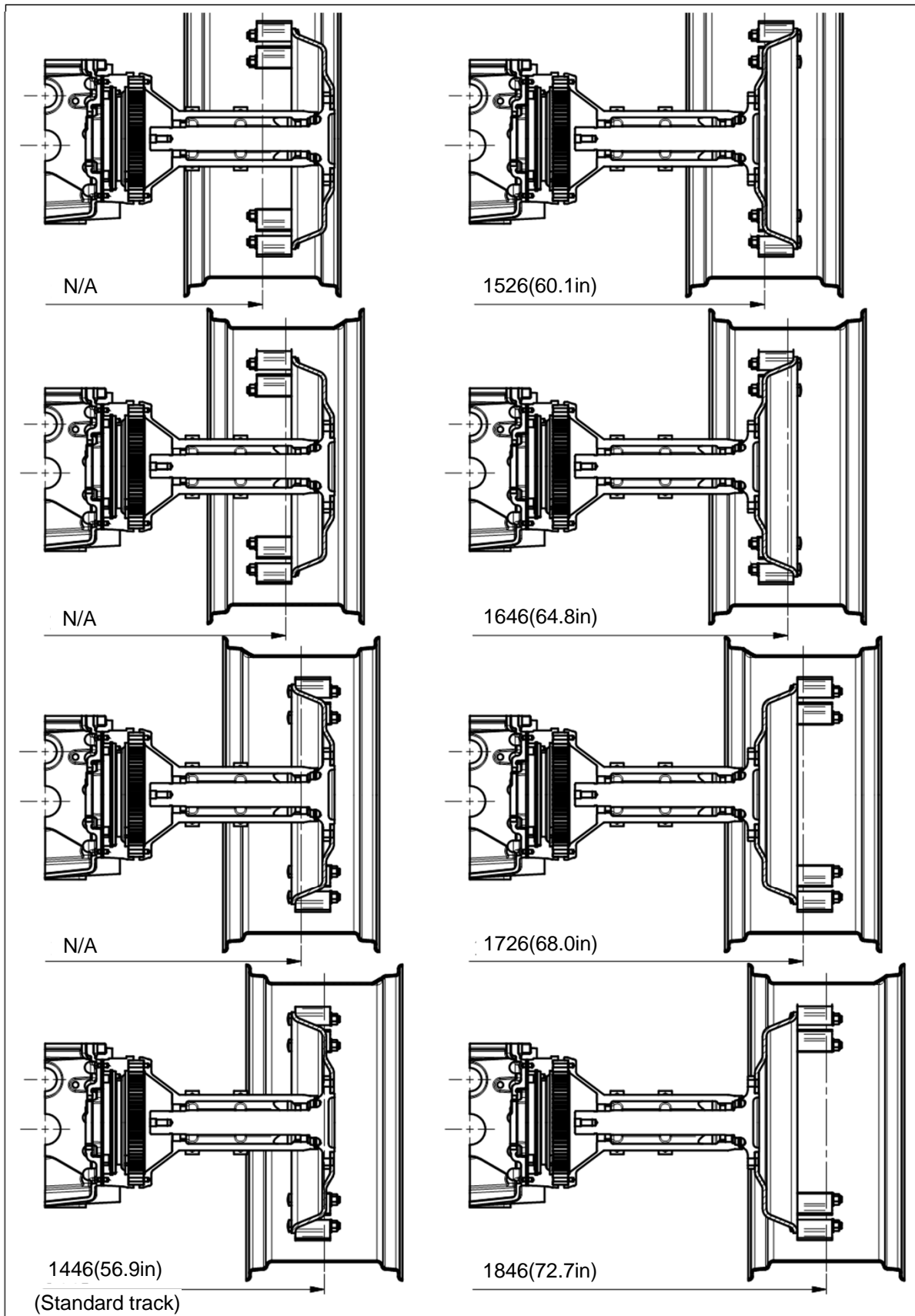

## (7) Using Front-end loader (if fitted)

### ① Safety precautions

- If attaching a non-approved front-end loader or heavy front-mounted implement, engine block or front axle can be damaged or broken. Contact your authorized local dealer.
- DO NOT attach any non-approved front-mounted implement by manufacturer. If it is ignored, and any warranty is not effective no longer.
- If an approved front-end loader is attached, multi-functional joystick lever in the right figure can provide you more convenient operation.
- When operating the tractor with front-end loader, The center of gravity of the tractor may be higher, and the stability of the vehicle may be worse than unattached vehicle.
  - DO NOT drive fast on a traffic load. The rolling or tipping of the tractor can be happened easily.
  - When loading/unloading the bucket on a slope, move the tractor straight against the slope.
  - DO NOT try to approach a stiff slope.
  - Attach the rear ballast on the 3-point linkage or rear wheels(if applicable) to prevent overload of the front axle and to improve the stability of the vehicle.
- When working with front-end loader, the front visibility of the tractor may be worse than unattached vehicle. Have to observe people and other vehicles around the tractor.
- DO NOT allow people under the front-end loader while lifted.
- DO NOT allow people on the bucket.

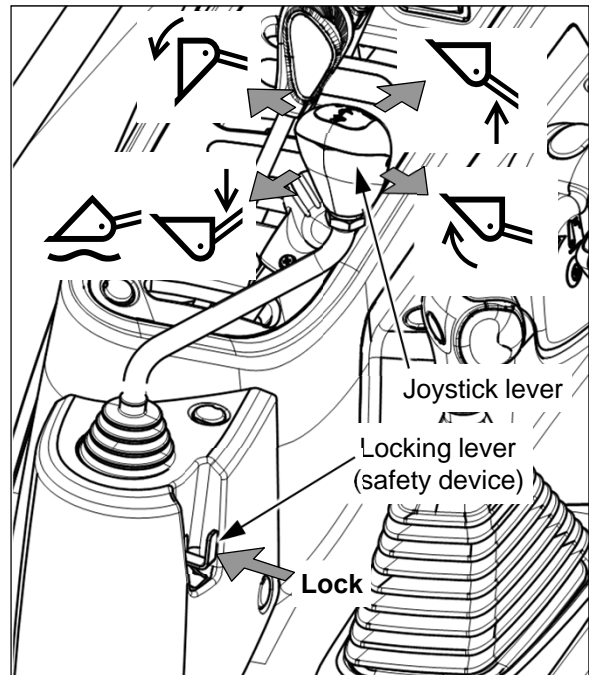

#### <Meaning of Symbols>

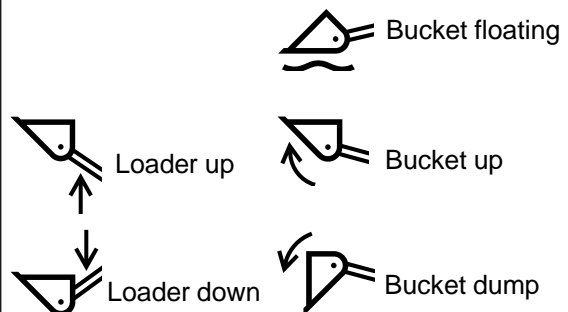

 <b>Warning</b>	<p><b>TO AVOID PERSONAL INJURY !</b></p> <ul style="list-style-type: none"> <li>▶ After using the front-end loader, push the locking lever to the lock position.</li> <li>▶ When leaving the tractor, lower down the front-end loader on the ground.</li> <li>▶ Do not lift the front-end loader to a height from which objects may fall or roll onto the driver.</li> <li>▶ Use always the correct attachment (grab forks, buckets.. etc.) for the specific task to perform and ensure that the load is securely kept in place.</li> </ul>
--	---

 <b>Caution</b>	<p><b>PRE-OPERATION CHECK, REAR BALLAST !</b></p> <p>► For tractor stability and operator's safety, rear ballast should be added to the rear of the tractor in the form of implements as counter weight like Back Hoe, Rotary Tiller, etc. The amount of rear ballast will be depend on the application.</p>
--	--

**② Connection of hydraulic hoses**

- Refer to the following instruction for connections of hydraulic hoses.
- For basic joystick lever;
  - Boom down ----- outlet ①
  - Boom up ----- outlet ②
  - Bucket up ----- outlet ③
  - Bucket dump ----- outlet ④
- The thread specification of outlet ports is PF 3/8. Use suitable quick couplers for hose connection. If possible, contact your authorized local dealer.

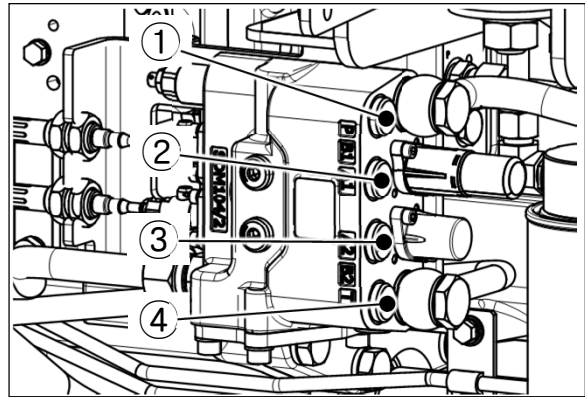

- The electric switches(if fitted) installed on the joystick lever are used to operate the solenoid valve having outlet ports ⑤,⑥ as below. When pressing these switches;

**Left-hand switch: Oil flows to outlet port ⑤**

**Right-hand switch: Oil flows to outlet port ⑥**

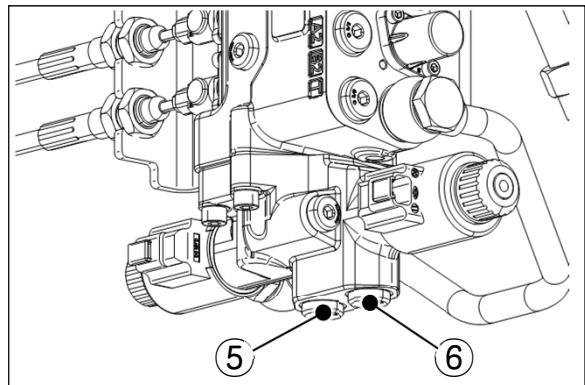
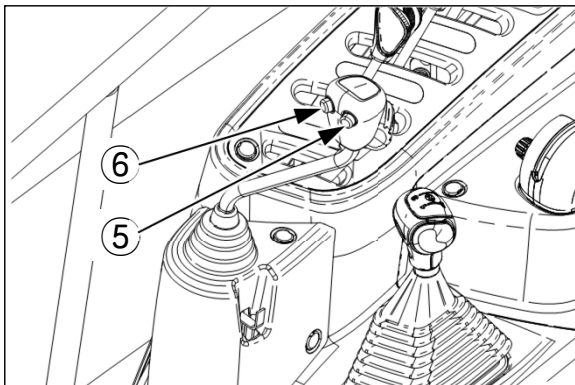

- After connecting the hoses, start the engine and check the leakage of the hydraulic lines.
- After lowering the front implement, check if the transmission oil level is marked between "Min" and "Max" scale on the oil gauge. If necessary, add new oil.

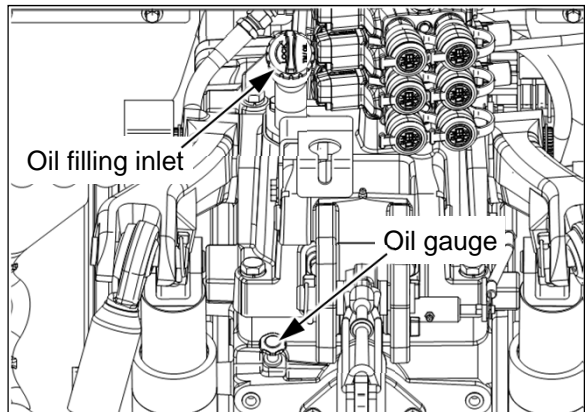
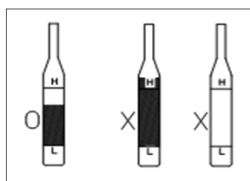



### ③ Attaching points for Front-end loader

- When attaching the front-end loader, refer to the drawings as below.

(Unit : mm)

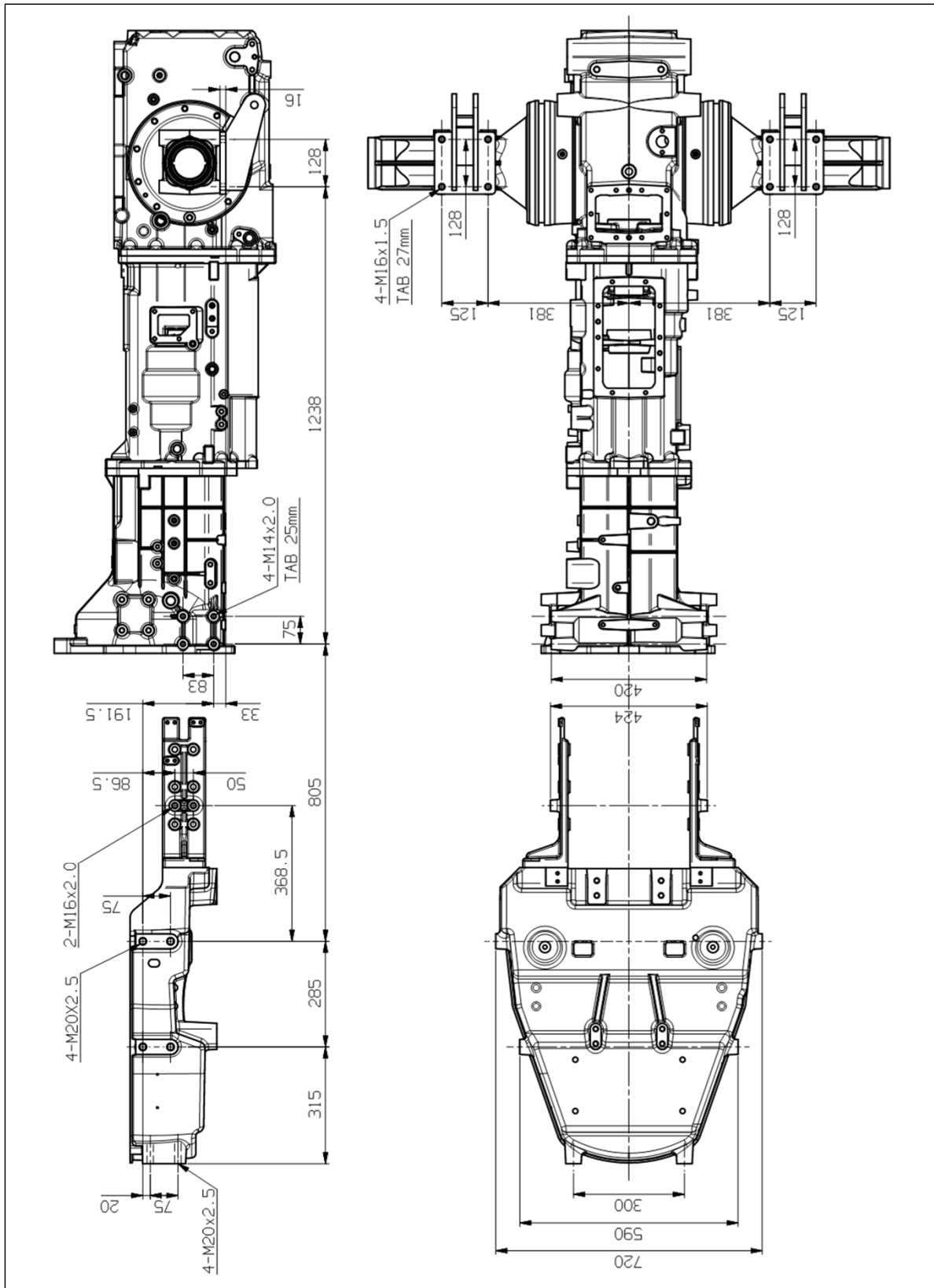

## (8) Adjusting Steering Angle

- The steering angle must be checked or adjusted in case of;
  - If the front wheel track is adjusted.
  - When the front tires are replaced with new one having bigger diameter or width.
  - When installing a front implement such as front-end loader.
- Comply with the following instructions.

- 1) Loosen the locking nuts on both sides.
- 2) Connect the front hook of the tractor to the suitable hoist by using a specified wire. And, lift up the front axle off the ground sufficiently.
- 3) Lift up one side of the front axle fully and turn the steering wheel to the left and right with checking that the clearances between tires and other parts are **over 20mm (0.8 in.) at least.**
- 4) At this time, set each steering stopper of the both sides to be contacted with the cast. Check all the possible interferences by combinations of the steering and oscillation of the front axle.
- 5) Tighten the locking nuts of the both sides.

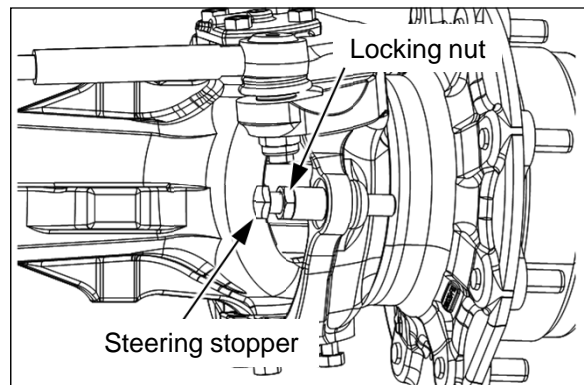

Notice	▶ DO NOT shorten the length of the steering stopper rather than factory condition. If the stopper does not contact to the cast at maximum steering condition, it can cause damage to the steering cylinders and linkage.
--------	--

## (9) Recommended maximum Specification of Implements

- When attaching implements to the tractor, refer to the following specifications recommended as maximum capacity of each implement. DO NOT attach a bigger implement than these specifications. For other implements, contact your authorized local dealer.

No.	Implements	Specification	MT563	MT568	MT573
1	Trailer	Max. vertical load (kg)	See chapter 4-5-(3) in this manual		
2	Mid mower	Max. cutting width (mm)	-	-	-
3	Rear mounted mower	Max. cutting width (mm)	2134 (84 in)	2134 (84 in)	2134 (84 in)
4	Flail Mower	Max. cutting width (mm)	2032 (80 in)	2032 (80 in)	2032 (80 in)
5	Sickle Bar	Max. cutting width (mm)	2438 (96 in)	2438 (96 in)	2438 (96 in)
6	Rear mounted Sprayer	Total weight (kg)	1000 (2205 lb)	1000 (2205 lb)	1000 (2205 lb)
7	Pull type Sprayer	Max. weight (kg)	See chapter 4-5-(3) in this manual		
8	Rotary Tiller	Max. tilling width (mm)	2050 (81 in)	2050 (81 in)	2100 (83 in)
9	Furrow Plow	Max. tilling width (mm)	2050 (81 in)	2050 (81 in)	2100 (83 in)
10	Bottom Plow	Max. size (mm)	1600 (63 in)	1600 (63 in)	1600 (63 in)
11	Disk harrow (pull type)	Max. working width (mm)	2050 (81 in)	2050 (81 in)	2100 (83 in)
12	Chisel Plow	Maximum width (mm)	2050 (81 in)	2050 (81 in)	2100 (83 in)
13	Front grader	Max. working width (mm)	2200 (86 in)	2200 (86 in)	2200 (86 in)
14	Rear blade	Max. working width (mm)	2134 (84 in)	2134 (84 in)	2134 (84 in)
15	Front loader	Max. lift capacity (kg) (@ bucket pivot)	1648 (3633 lb)	1648 (3633 lb)	1648 (3633 lb)
16	Landscape Rake	Max. working width (mm)	2134 (84 in)	2134 (84 in)	2134 (84 in)
17	Box blade	Max. working width (mm)	2100 (83 in)	2100 (83 in)	2100 (83 in)
18	Backhoe	Max. weight (kg) (W/O Bucket)	-	-	-
19	Snow Blade	Max. working width (mm)	2100 (83 in)	2100 (83 in)	2100 (83 in)
20	Snow Blower	Max. working width (mm)	2100 (83 in)	2100 (83 in)	2100 (83 in)

## (10) Ballasting weights (optional)

### Tractor ballasting

For sufficient traction and maximum performance in heavy draft operations, and to counterbalance rear-mounted equipment, weight should be added to the tractor in the form of liquid ballast, cast iron weights, or a combination of both. Only enough weight should be added to provide good traction and stability. Adding more weight than is needed results in unnecessary soil compaction, increased rolling resistance, and higher fuel consumption.

**NOTE:** *When adding weight to the tractor, verify the tire pressure is correct. See chapter 4-5-(5), "Tires and Load capacity" in this manual for tire pressures and permissible loads.*

Front end ballast may be required for stability and steering control when weight is transferred from the front wheels to the rear wheels as an implement is raised by the tractor three-point hitch.

Use the following as a general guide:

- Ballast the tractor (less implement) so that approximately one-third of the tractor weight is on the front wheels. For optimum traction, tractors equipped with 4WD should be ballasted so that **40 – 45%** of machine weight is on the front wheels.
- When a rear mounted implement is raised to the transport position, the front wheel reaction should be at least **20%** of tractor weight.
- Add additional front end ballast as required for stability during operation and transport. Tractor front end ballast may not always maintain satisfactory stability if the tractor is operated at high speed on rough terrain. Reduce tractor speed and exercise caution under these conditions.
- When using front-mounted equipment, add weight to the rear axle to maintain good traction and stability. Front-mounted equipment varies in weight. Refer to equipment manual for ballasting.

### Weighting limitations

**The weighting limitations that follow are limitations only. They do not imply that the tractor should be weighted to attain the weights given. Use only enough weight to obtain good performance.**

## ① Front ballasting weights (optional)

- It is used to balance the front/rear weight of the tractor.
- To remove the front ballast weights, unscrew the locking nut of the front ballast weights and disassemble the weight plates one by one.

Front ballast weight (kg) :

40kg x 4ea = 160kg or

40kg x 6ea = 240kg

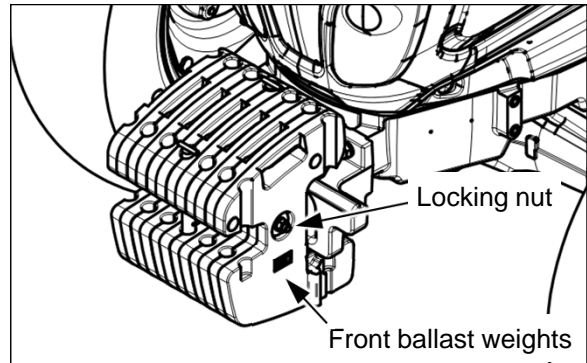

- To remove the bumper, connect the bumper to the suitable hoist and unscrew the bolts in the right figure.

Bumper weight (kg) : 42kg

- When assembling the ballast weights, comply with the reverse procedure of the disassembly.
- For additional ballast weights and adjustment methods, contact your authorized local dealer.

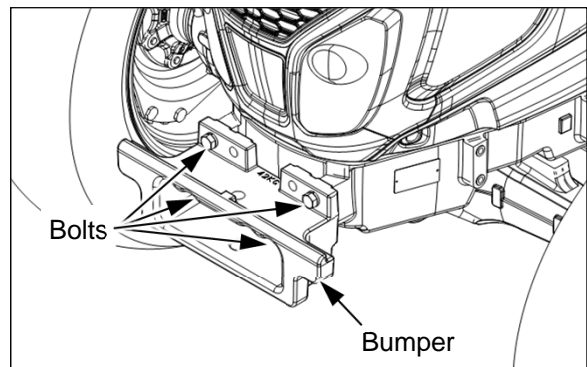

Warning

### Heavy parts!

- ▶ The ballast weights are very heavy. When removing/attaching the ballast weights, please be careful and use a suitable hoist and specific equipment to move the heavy parts. Failure to comply could result in death or serious injury.

## ② Rear ballasting weights (optional)

### - Rear wheel weights (Optional)

- To remove the rear ballast weights, connect the bumper to the suitable hoist, and unscrew the bolts in the right figure and disassemble the weight plates one by one if necessary.  
Rear weight (kg) : 45kg x 2ea = 90kg or  
45kg x 4ea = 180kg
- When assembling the ballast weights, comply with the reverse procedure of the disassembly.
- For additional ballast weights and adjustment methods, contact your authorized local dealer.

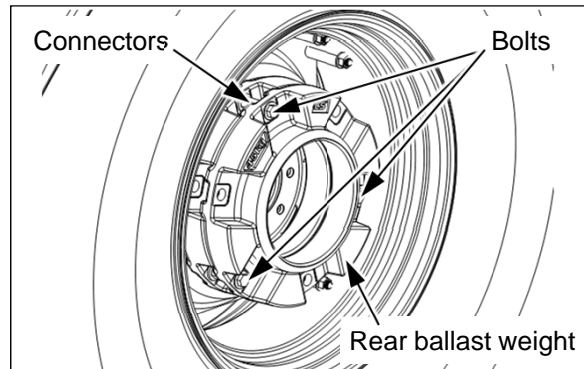

### - Rear ballast weights on the 3-point linkage

- To mount the ballast weights on the rear of the tractor, an additional weight bracket must be installed on the rear three-point hitch.
- Contact your authorized local dealer for the bracket.
- If you hard to get the bracket, you can use a equivalent weight rear implement as the ballasting weight.



Warning

#### Heavy parts!

- ▶ The ballast weights are very heavy. When removing/attaching the ballast weights, please be careful and use a suitable hoist and specific equipment to move the heavy parts. Failure to comply could result in death or serious injury.

## (11) Working in hazardous area

**Level of protection against hazardous substances: For cabin model**, it provides protection against hazardous substances **according to EN15695-1:2009 (Category 2)**. But it can provide only dust protection level by pressurizing air in the cabin with air filters. Do not use the tractor with crop sprayers in hazardous area. If unavoidable, comply with the following instructions.

### ① Cabin air filters (LH/RH)

- When operating with pesticides, cabin air filters should be replaced with specific charcoal filters. Contact your authorized local dealer.
- In additional, you should wear the protective clothing, globes, mask, etc. before operating in such a hazardous spraying area.
- These filters must only be fitted when working with pesticides and replaced with the normal paper filters at the end of work.

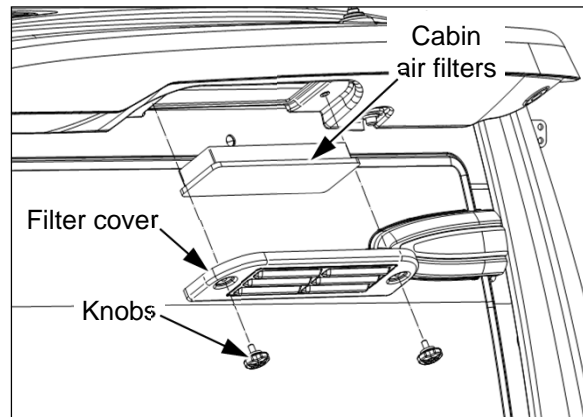

 Caution	<ul style="list-style-type: none"> <li>▶ Do not use these filters during other work, as they will quickly become clogged with dust. When replacing the charcoal filters at the end of spraying work, return them to the original packaging and make sure that they are carefully sealed.</li> <li>▶ The charcoal filters last for approximately 50 hours of work. They must, however, be replaced each year. If, when working with pesticides, toxic odors are noted, stop the work immediately and replace the filters with new one.</li> <li>▶ These filters must never be washed or cleaned with compressed air. Discarded filters must not be thrown away. Take disposed filters to authorized collection points.</li> </ul>
---	--

 Warning	<ul style="list-style-type: none"> <li>▶ The charcoal filters do not guarantee full protection against all pesticides.</li> <li>▶ These specific filters only reduce the harmful effects of these products. As a result, operator has to comply with the safety rules recommended for using each single product. Wear the protection clothing, globes, mask, etc. before operating in that area.</li> <li>▶ DO NOT operate the tractor in heavy pesticides or other hazardous spraying area.</li> </ul>
---	---

Notice	<ul style="list-style-type: none"> <li>▶ The filters are made of specially treated media with a rubber sealing strip bonded around the sides. Take care not to damage the element during installation.</li> </ul>
--------	---

### ② Cleaning the cabin inside

- Protective clothing worn when handling the sprayer with pesticides or when carrying out external works, must be removed and stored away carefully before re-entering the cabin.
- After working with pesticides, ventilate the cabin and clean the inside parts (interior trim, panels, step, etc.) of the cabin with clean damp cloth to remove the chemical residue.

## 4-6. Driving speed

- Driving speed of the tractor or revolution speed of the PTO shaft must be selected appropriately depending on the type of work, tires or ground conditions. For safety, operate the tractor at a suitable speed. (Unit: Km/h → Mile/h)

### ① Synchro-shuttle models (Global market)

#### ● Standard transmission (F12xR12)

Main gear		1				2				3				
Range gear		1	2	3	4	1	2	3	4	1	2	3	4	
14.9 -30	F	km/h	1.52	2.14	2.87	3.70	4.44	6.26	8.40	10.84	12.30	17.35	23.27	30.02
		mph	0.94	1.33	1.78	2.30	2.76	3.89	5.22	6.74	7.64	10.78	14.46	18.66
	R	km/h	1.69	2.38	3.19	4.12	4.95	6.98	9.36	12.07	13.70	19.32	25.91	33.43
		mph	1.05	1.48	1.99	2.56	3.07	4.33	5.81	7.50	8.51	12.00	16.10	20.77
16.9 -30	F	km/h	1.58	2.23	2.99	3.86	4.63	6.52	8.75	11.29	12.81	18.07	24.23	31.27
		mph	0.98	1.38	1.86	2.40	2.87	4.05	5.44	7.02	7.96	11.23	15.06	19.43
	R	km/h	1.76	2.48	3.33	4.29	5.15	7.26	9.74	12.57	14.27	20.12	26.98	34.82
		mph	1.09	1.54	2.07	2.67	3.20	4.51	6.05	7.81	8.87	12.50	16.77	21.63

Note) Engine rated speed : 2500rev/min, 14.9-30: Rc=683mm, 16.9-30: Rc=712mm

#### ● Creeper transmission (F20xR20, optional)

Main gear		1				2				
Range gear		1	2	3	4	1	2	3	4	
14.9-30	F	km/h	0.16	0.23	0.31	0.40	0.47	0.67	0.90	1.16
		mph	0.10	0.14	0.19	0.25	0.30	0.42	0.56	0.72
	R	km/h	0.18	0.25	0.34	0.44	0.53	0.75	1.00	1.29
		mph	0.11	0.16	0.21	0.27	0.33	0.46	0.62	0.80
16.9-30	F	km/h	0.17	0.24	0.32	0.41	0.49	0.70	0.94	1.21
		mph	0.10	0.15	0.20	0.26	0.31	0.43	0.58	0.75
	R	km/h	0.19	0.27	0.36	0.46	0.55	0.78	1.04	1.34
		mph	0.12	0.16	0.22	0.29	0.34	0.48	0.65	0.83

Note) Engine rated speed : 2500rev/min, 14.9-30: Rc=683mm, 16.9-30: Rc=712mm



## ② Power shuttle models (optional, Global market)

### ● Standard transmission (F12xR12)

Main gear		1				2				3				
Range gear		1	2	3	4	1	2	3	4	1	2	3	4	
14.9 -30	F	km/h	1.52	2.14	2.87	3.70	4.44	6.26	8.40	10.84	12.30	17.35	23.27	30.02
		mph	0.94	1.33	1.78	2.30	2.76	3.89	5.22	6.74	7.64	10.78	14.46	18.66
	R	km/h	1.63	2.30	3.09	3.99	4.78	6.74	9.05	11.67	13.25	18.68	25.05	32.33
		mph	1.01	1.43	1.92	2.48	2.97	4.19	5.62	7.25	8.23	11.61	15.57	20.09
16.9 -30	F	km/h	1.58	2.23	2.99	3.86	4.63	6.52	8.75	11.29	12.81	18.07	24.23	31.27
		mph	0.98	1.38	1.86	2.40	2.87	4.05	5.44	7.02	7.96	11.23	15.06	19.43
	R	km/h	1.70	2.40	3.22	4.15	4.98	7.02	9.42	12.16	13.80	19.45	26.09	33.67
		mph	1.06	1.49	2.00	2.58	3.10	4.36	5.85	7.55	8.57	12.09	16.21	20.92

Note) Engine rated speed : 2500rev/min, 14.9-30: Rc=683mm, 16.9-30: Rc=712mm

### ● Creeper transmission (F20xR20, optional)

Main gear		1				2				
Range gear		1	2	3	4	1	2	3	4	
14.9-30	F	km/h	0.16	0.23	0.31	0.40	0.47	0.67	0.90	1.16
		mph	0.10	0.14	0.19	0.25	0.29	0.42	0.56	0.72
	R	km/h	0.17	0.25	0.33	0.43	0.51	0.72	0.97	1.25
		mph	0.11	0.15	0.21	0.26	0.32	0.45	0.60	0.78
16.9-30	F	km/h	0.17	0.24	0.32	0.41	0.49	0.70	0.94	1.21
		mph	0.10	0.15	0.20	0.26	0.31	0.43	0.58	0.75
	R	km/h	0.18	0.26	0.34	0.44	0.53	0.75	1.01	1.30
		mph	0.11	0.16	0.21	0.28	0.33	0.47	0.63	0.81

Note) Engine rated speed : 2500rev/min, 14.9-30: Rc=683mm, 16.9-30: Rc=712mm



# 5. Lubrication and Maintenance

## 5-1. General information



- Adequate lubrication and maintenance on a regular schedule is vital to maintaining your equipment. To ensure long service and efficient operation, follow the lubrication and maintenance schedules outlined in this manual. The use of proper fuels, oils, grease and filters, as well as keeping the systems clean, will also extend tractor and component life.

**NOTICE:** While any company can perform necessary maintenance or repairs on your equipment, we strongly recommends that you use only authorized local dealers and products that meet the given specifications. Improperly or incorrectly performed maintenance and repair voids the equipment warranty and may affect service intervals.

**NOTICE:** Always use genuine replacement parts, oils and filters to ensure proper operation, filtration of engine and hydraulic systems. See your authorized local dealer for additional oil quantities. Regular lubrication is the best insurance against delays and repairs. Proper lubrication will extend tractor life. Refer to the following charts for lubricants and service intervals.

**NOTICE:** Failure to complete the required maintenance at the recommended intervals can cause unnecessary downtime.



- The intervals listed in the Lubrication Chart are guidelines to be used when operating in normal conditions. Adjust the intervals for operating in adverse environmental and working conditions. The intervals should be shortened for sandy, dusty and extremely hot operating conditions.

 Warning	<p>▶ <b>Avoid injury!</b></p> <ol style="list-style-type: none"> <li>1. Disengage all drives.</li> <li>2. Engage parking brake.</li> <li>3. Lower all attachments to the ground, or raise and engage all safety locks.</li> <li>4. Shut off engine.</li> <li>5. Remove key from key switch.</li> <li>6. Wait for all tractor movement to stop.</li> </ol> <p>Failure to comply could result in death or serious injury.</p>
 Warning	<p>▶ <b>Entanglement hazard!</b></p> <p>Disengage the Power Take-Off (PTO), turn off the engine, and remove the key. Wait for all movement to stop before leaving the operator's position. Never adjust, lubricate, clean, or unplug tractor with the engine running.</p> <p>Failure to comply could result in death or serious injury.</p>
 Warning	<p>▶ <b>Illustrations in this manual may show protective shielding open or removed to better illustrate a particular feature or adjustment.</b></p> <p>Replace all shields before operating the tractor.</p> <p>Failure to comply could result in death or serious injury.</p>

- Always clean the area around dipsticks, fill caps, and check plugs when checking fluid levels. Failure to clean these areas may allow contamination to enter the system. Drain, flush and refill the system any time you suspect it is contaminated.

## (1) Tightening Torque for normal assembly

- Check if the bolts or nuts of each part are loosened. If necessary, tighten it again as referring to the following table. For additional hardware, contact your authorized local dealer.

Strength class marks		
4T	8T	10.9T
		

Spec.	Tool (mm)	Strength	Hardware tightening torque (kg.cm)		
			Re-use	Permanent	Maximum
M8 X 1.25	12	8.8	202	243	268
		10.9	290	348	394
		12.9	339	407	460
M10 X 1.25	17	8.8	434	521	576
		10.9	621	746	845
		12.9	727	872	987
M12 X 1.25	19	8.8	769	922	1019
		10.9	1100	1320	1496
		12.9	1286	1543	1748
M12 X 1.75	19	8.8	695	835	922
		10.9	996	1195	1354
		12.9	1164	1397	1582
M14 X 1.5	24	8.8	1209	1451	1603
		10.9	1731	2077	2354
		12.9	2023	2428	2749
M16 X 1.5	24	8.8	1832	2198	2429
		10.9	2622	3147	3567
		12.9	3065	3679	4166
M18 X 1.5	27	8.8	2764	3317	3648
		10.9	3821	4585	5198
		12.9	4467	5360	6070
M20 X 1.5	30	8.8	3861	4633	5095
		10.9	5337	6405	7260
		12.9	6240	7488	8479
M22 X 1.5	32	8.8	5163	6195	6812
		10.9	7136	8564	9708
		12.9	8343	10011	11337
M24 X 2	36	8.8	6552	7862	8646
		10.9	9057	10869	12320
		12.9	10588	12706	14389
M30 X 2	46	8.8	13365	16038	17636
		10.9	18475	22170	25131
		12.9	21598	25917	29350

## Identification markings

### Metric hex bolt head

1. Manufacturer's identification
2. Property class

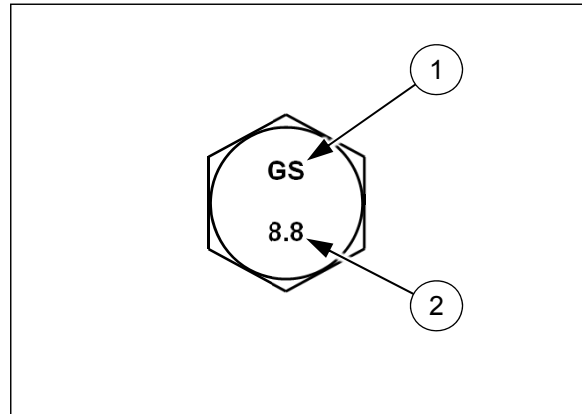

## (2) Standard torque data for hydraulics

### Installation of adjustable fittings in straight thread O-ring bosses

1. Lubricate the O-ring by coating it with a light oil or petroleum.
2. Install the O-ring in the groove adjacent to the metal backup washer which is assembled at the extreme end of the groove.
3. Install the fitting into the straight thread boss until the metal backup washer contacts the face of the boss.

**NOTICE:** Do not over tighten and distort the metal backup washer.

4. Position the fitting by turning out (counterclockwise) up to a maximum of one turn.
5. Holding the pad of the fitting with a wrench, tighten the locknut and washer against the face of the boss.

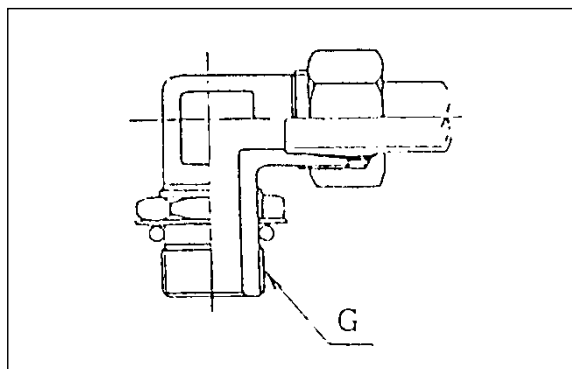

### Standard torque data for hydraulic tubes and fittings

**NOTICE:** These torques are recommended for hydraulic tubes of your tractor. When assemble the hydraulic lines, refer to the following torques on each application. Before installing and torquing pipe fittings, Clean the threads and faces.

Thread	Torque		Figure	Remarks
	N · m	{kgf · m}		
G 1/4	49~69	5~6		1. Materials of threaded hole:  Cast or steel.
G 3/8	59~69	6~7		
G 1/2	78~88	8~9		

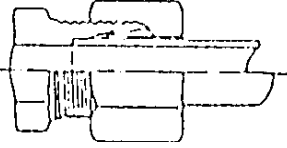
Pipe spec.		Pre-torque		Tightening torque		Figure	Remarks
Outer dia.	Thickness	N · m	{kgf · m}	N · m	{kgf · m}		
8	1~1.5	29~34	3~3.5	29~34	3~3.5		Pipe material: OST
10	1~1.5	29~39	3~4	34~49	3~3.5		
12	1~2.5	44~59	4.5~6	49~69	5~7		
15	1~2.5	69~98	7~10	88~118	9~12		
18	1.5~2	118~147	12~15	146~167	15~17		
20	2~3	147~177	15~18	167~206	17~21		
22	2	177~206	18~21	196~235	20~24		
27.2	2.8	323~343	33~35	343~373	35~38		SGP

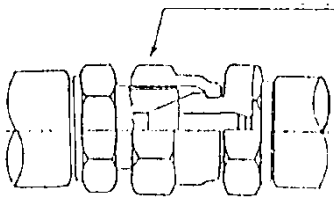
Thread	Torque		Figure	Remarks
	N · m	{kgf · m}		
G 1/8	15	1.5		
G 1/4	25	2.6		
G 3/8	49	5		
G 1/2	59	6		
G 3/4	118	12		

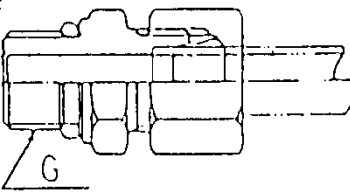
Thread	Torque		Figure	Remarks
	N · m	{kgf · m}		
G 1/8	20~25	2~2.5		1. Materials of threaded hole: Cast or steel.
G 1/4	39~49	4~5		
G 3/8	49~59	5~6		
G 1/2	59~69	6~7		
G 3/4	118~127	12~13		

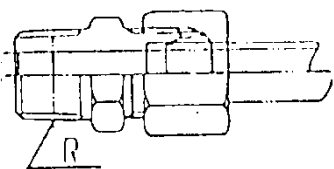
Thread	Torque		Figure	Remarks
	N · m	{kgf · m}		
G 1/8	15	1.5		1. Apply seal tape before assembling 2. Threaded hole: Taper or parallel steel or cast
G 1/4	25	2.6		
G 3/8	49	5		
G 1/2	59	6		

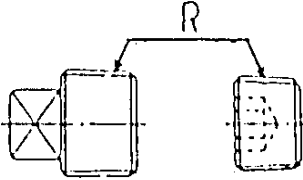
Thread	Torque		Figure	Remarks
	N · m	{kgf · m}		
G 1/8	15	1.5		1. Apply seal tape before assembling 2. Threaded hole: Taper or parallel steel or cast
G 1/4	25	2.6		
G 3/8	49	5		
G 1/2	59	6		
G 3/4	118	12		

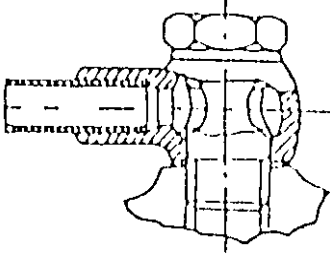
Thread	Holes	Torque		Figure	Remarks
		N · m	{kgf · m}		
G 1/4	2	39~44	4.0~4.5		1. Materials of threaded hole: Cast or steel. 2. Assemble with packing washers. 3. Holes: Number of holes on the same section plane.
G 3/8	2	47~54	4.8~5.5		
	4	39~44	4.0~4.5		
G 1/2	4	47~54	4.8~5.5		
G 3/4	4	59~69	6.0~7.0		
M 12	2	20~27	2.0~2.8		
M 14	2	34~39	3.5~4.0		
	4	29~34	3.0~3.5		
M 16	2	49~59	5.0~6.0		
	4	39~44	4.0~4.5		



### **(3) General specification - Diesel fuel**

- Only use diesel fuel that conforms to “**Lubricants and Capacity**” in this manual or equivalent in your engine. Do not use any other low grade diesel fuel.

**NOTICE:** *Use of other low grade diesel fuels will result in loss of engine power, high fuel consumption, and damage to the exhaust after-treatment system (if equipped).*

**NOTE:** *When operating the tractor in very cold climates, the use of winter blended fuel is permitted for a short period of time. See your fuel supplier for winter fuel requirements in your area.*

#### **Fuel conditioner**

- Diesel fuel conditioner is available from your authorized local dealer. Instructions for the use of the fuel conditioner is on the container.
- The use of diesel fuel conditioner will:
  - Clean fuel injectors, valves, and manifolds for increased service life.
  - Disperse insoluble gummy deposits that form in the fuel system.
  - Separate moisture from the fuel.
  - Stabilize fuel in storage.

**NOTICE:** *Use only manufacturer approved biocide additives to prevent damage to the exhaust after-treatment system (if equipped).*

## (4) Biodiesel fuel

Fatty Acid Methyl Ester Biodiesel (Biodiesel Fuel) consists of a family of fuels derived from vegetable oils treated with methyl esters.

**NOTICE:** Biodiesel Fuel blends are approved for your engine only if they comply with **EN14214** Specification Standards or **ASTM D6751**.

**NOTICE:** It is imperative that you check which blend is approved for your engine with your authorized local dealer. Be aware that the use of Biodiesel Fuel that does not comply with the Standards mentioned above could lead to severe damage to the engine and fuel system of your tractor. The use of fuels that are not approved may void manufacturer warranty coverage.

### Biodiesel approved blend

The use of biodiesel blends meeting Specification Standards ASTM 6751 or EN14214 are approved for your engine **up to B7 (7% blend ratio)**. It is highly recommended to use biodiesel fuel from accredited suppliers to maintain quality and consistency of the fuel.

### Biodiesel Fuel Usage Conditions

**NOTICE:** The Biodiesel Fuel must meet the fuel Specification mentioned above.

Biodiesel Fuel must be purchased from a trusted supplier that understands the product and maintains good fuel quality. Biodiesel Fuel must be pre-blended by the supplier. Mixing Biodiesel Fuels on-site can result incorrect mixture that can lead to problems with both engine and fuel system.

Engine performance is affected by the use of Biodiesel Fuel. There may be up to **12%** reduction in power or torque depending on the blend used.

**NOTICE:** DO NOT modify the engine and/or injection pump settings to recover the reduced performance.

The reduced power must be accepted if using any Biodiesel Fuel blend.

Some modification may be required to allow your engine to run Biodiesel Fuel. Consult your dealer for complete information on these modifications.

Biodiesel Fuel has a higher cloud point than Diesel Fuel.

**NOTICE:** The use of high Biodiesel Fuel blends are not recommended in cold weather conditions.

With Biodiesel Fuels, it may be necessary to change the engine oil, engine oil filter and fuel filter elements more frequently than with Diesel Fuels. For maintenance interval of the fuel filter, refer to the following table.

Biodiesel Fuel	Maintenance Interval of the fuel filter
≤ BD 7	500 hours
≤ BD 12	400 hours
≤ BD 20	250 hours

Biodiesel Fuel can remove rust and particles from the inside of on-site fuel storage tanks that would normally adhere to the sides of the tank. Like particle deposits that commonly occur with Diesel Fuel, these particles can become trapped by the tractor fuel filters, causing blockage and shortening filter life. In cold weather, this is more likely to happen. Consult your authorized local dealer for information on cold weather operation and proper maintenance intervals when using any Biodiesel Fuel blend.

When handling Biodiesel Fuel, care must be taken not to allow water into the fuel supply. Biodiesel Fuel will actually attract moisture from the atmosphere.

Fuel tanks must be kept as full as possible to limit the amount of air and water vapors in them. It may be necessary to drain the fuel filter water tap more frequently.

Potential oxidation and stability could be a problem with the fuel stored in the tractor.

***NOTICE:*** *Tractor must not be stored for more than three months with Biodiesel Fuel blends in the fuel system.*

If long storage periods are necessary, the engine must run on Diesel Fuel for 20 hours to flush the Biodiesel Fuel out of the engine fuel system prior to storage.



***NOTICE:*** *Biodiesel Fuel must not be stored in on-site storage tanks for more than three months.*

Any spillage of Biodiesel Fuel must be cleaned up immediately before it can cause damage to the environment and the paint finish of the tractor.

Before using Biodiesel Fuel blends you should consult with your dealer to receive full information about the approved blend for your tractor and any detailed conditions of its usage.

***NOTICE:*** *Be aware that not fulfilling the requirements and conditions of Biodiesel Fuel usage will void your tractor's Warranty coverage.*

## (5) Refueling the tractor

 Warning	<b>Fire hazard!</b>
	<p>▶ When handling diesel fuel, observe the following precautions:</p> <ol style="list-style-type: none"><li>1. Do not smoke. Keep any type of flame away.</li><li>2. Never fill the tank when the engine is running.</li><li>3. Wipe up spilled fuel immediately. Always tighten the fuel tank cap securely. Failure to comply could result in death or serious injury.</li></ol>

- The fuel tank filler cap ① is installed as shown in the right-hand figure. Observe the following:
  1. Before removing the cap, wipe all dust and dirt from around the cap to prevent debris from falling into the tank while filling.
  2. Use an approved fuel container and check the inside of the container periodically for cleanliness.  
*For fuel tank capacity, see chapter 5-3, "Lubricants and Capacity" or the last page in this manual.*
  3. If there is no filter on the storage tank or fuel container, filter the fuel through a 100-mesh or finer screen when filling the tractor fuel tank.
  4. Keep the tractor tank as full as possible (without filling to capacity) to minimize condensation. Fill to the bottom of the filler neck to allow room for expansion.

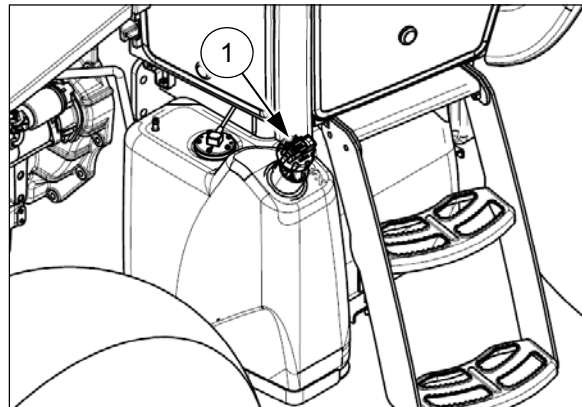

**NOTE:** It is a good practice to fill the fuel tank at the end of each day, as this will reduce overnight condensation.

**NOTE:** The fuel cap is a vented-type. Use only an approved replacement cap to prevent fuel system-related problems.

- Do not mix gasoline, alcohol or blended fuels to diesel fuel. These mixtures are explosive in fuel tank.
- Never remove the fuel cap or refuel with the engine running or hot.
- Maintain control of the fuel filler nozzle when filling the fuel tank.
- Never use fuel for cleaning purposes.
- Arrange fuel purchases so that summer grade fuels are not held over and used in the winter.
- Before handling Bio-diesel, refer to the chapter 5-1-(4) in this manual.

## (6) Change engine coolant to Organic Acid Technology (OAT) coolant

- Depending on the date of manufacture, your cooling system may be equipped with conventional ethylene glycol coolant or an Organic Acid Technology (OAT) coolant solution. You can easily identify **OAT coolant solution** by its yellow color. You should never mix the coolant types.
- The coolant solution used must meet the manufacturer's material specifications for either coolant type. Refer to the chapter 5-3, "Lubricants and Capacity" in this manual.

**NOTICE:** NEVER mix OAT coolant with conventional coolant. Under no circumstances should you top off a cooling system with only water. You can use a refractometer to check the concentration level. You should not use Supplemental Coolant Additives (SCA) when using **OAT coolant solution**. Change the coolant solution at the recommended change interval.

If you need to change a tractor from conventional coolant to OAT coolant or vice versa, you should follow the "Changing coolant types" procedure below to attain the full benefit of the coolant.

### Changing coolant types

To change coolant from OAT coolant to conventional coolant (or vice versa):

1. Empty the engine cooling system by draining the coolant into a suitable container.
2. Fill the system with clean water.
3. Start the engine and run the engine for at least **30 min**.

**NOTE:** Make sure that you activate the heating system (if equipped) to circulate fluid through the heater core.

4. Repeat Steps 1 to 3 for a total of two washes.
5. Fill the system with conventional coolant (or OAT coolant).
6. Operate the engine until it is warm. Inspect the tractor for leaks.
7. If you are changing to OAT coolant, then attach the decal to indicate the use of OAT coolant in the cooling system.

### Definitions

#### Conventional coolant:

A coolant that relies on inorganic inhibitors such as silicates, nitrites, and phosphates for corrosion and cavitation protection.

#### Organic Acid Technology (OAT) coolant:

A coolant that relies on inhibitors such as organic acid salts for corrosion and cavitation protection.

## (7) Access for maintenance

### ① Opening Hood

- For safety, the hood must be closed and correctly latched before operating the tractor.
- The hood is hinged at the rear and a gas cylinder is attached to provide easy access to the engine for check and maintenance.
- To open the hood, push the hood opening button and lift the hood upward.
- To close the hood, pull the hood and push it down to the locking position slightly.

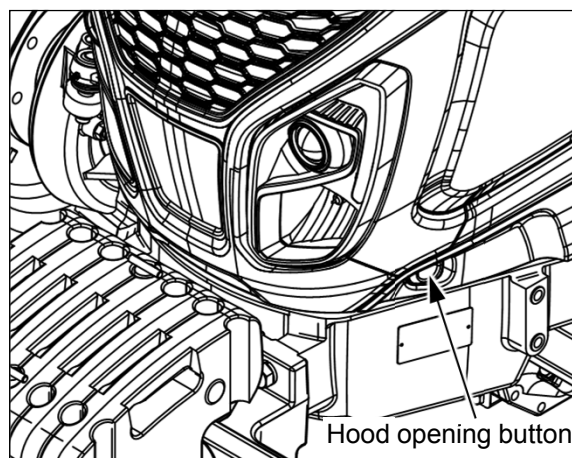

 <b>Caution</b>	<ul style="list-style-type: none"> <li>▶ After the engine has stopped completely, you have to open the hood for checking.</li> <li>▶ If you open the hood while the engine is running, it can cause serious damage by intended or unintended access to the rotating shaft, pulley, V-belt, cooling fan of the engine or engine application parts. PLEASE BE CAREFUL.</li> </ul>
--	---

### ② Jacking points

- The jacking points for maintenance is depending on serviced parts case by case. Do not hesitate to contact your authorized dealer for asking.
- Do not use the front axle assembly or steering linkage and cylinder for jacking point. These components have some rotating pivots and/or does not have enough structural strength.
- For general maintenance, use a flat surface under the engine frame end or bumper for jacking point, and additionally connect the front towing hook to the hoist for safety.
- For rear jacking points, two flat surfaces under the rear axle housing is recommended, and additionally use the top-link bracket and its pin for lifting point after removing the top-link.

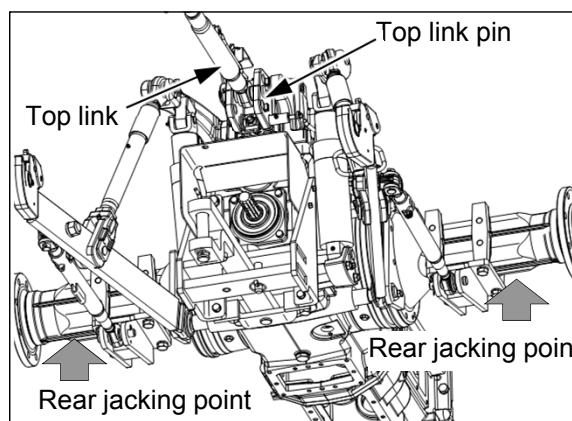
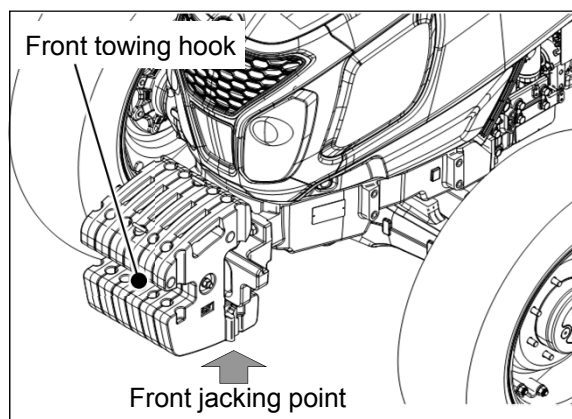

 <b>Caution</b>	<ul style="list-style-type: none"> <li>▶ When lifting the rear of the tractor, apply chocks to the slots between front axle and engine frame symmetrically to prevent the tractor from rolling.</li> </ul>
--	--

## 5-2. Maintenance chart

- Periodic maintenance not only extends the service life of the tractor but also serves to ensure safe operation. **The maintenance chart shows the standard service intervals. If you notice any abnormal symptoms, make sure to carry out the inspection and maintenance work, regardless of recommended service intervals in this maintenance chart.**
- Appropriate service intervals vary depending on the usage and operating conditions. In extreme dusty/dirty environments, the service intervals have to be shorter than normal condition.

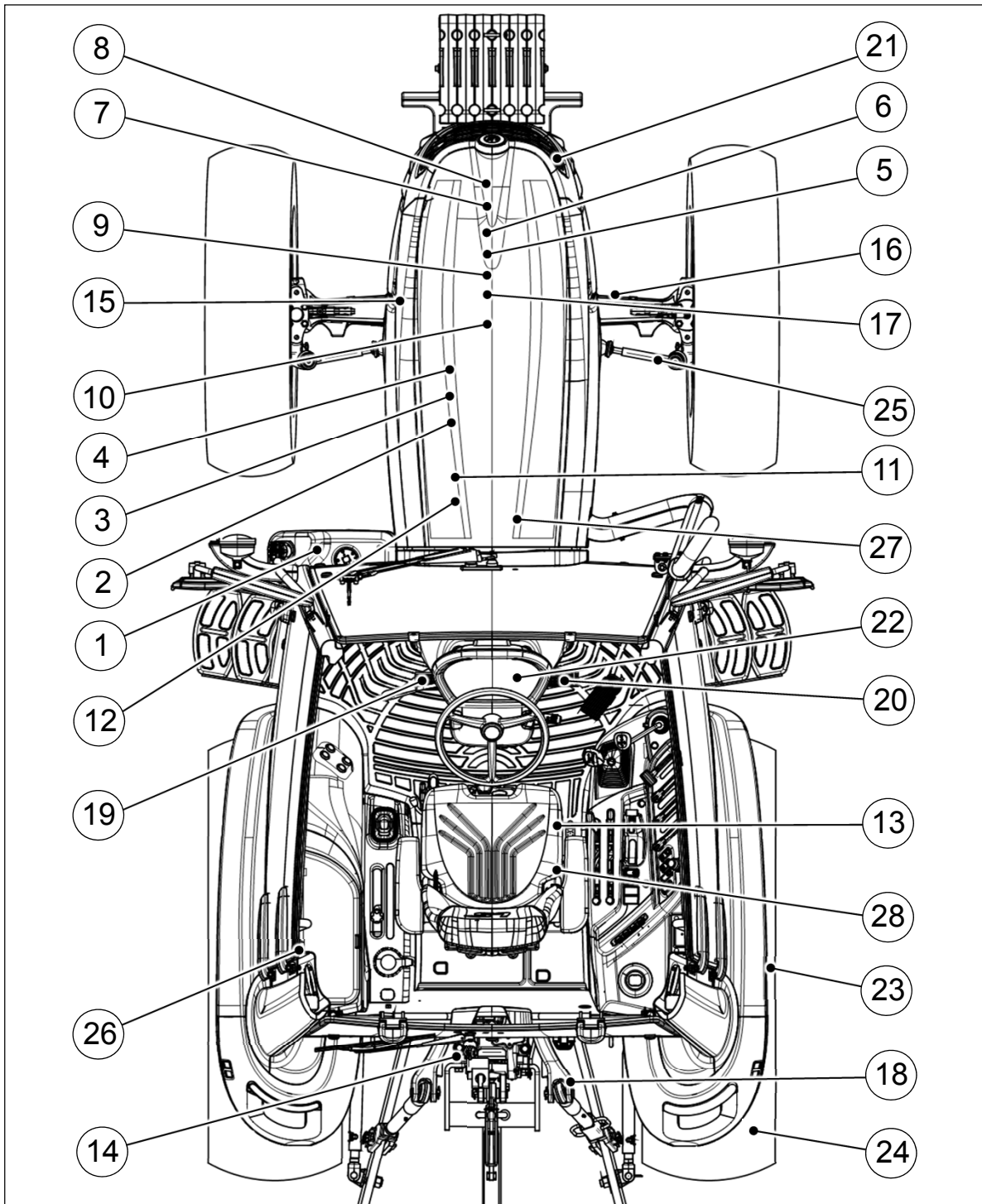

No.	Checking Parts	Page No.	Check period (Every ---- (hr))							
			Daily	50	100	300	500	1000 or 1-yr	1500 or 2-yr	3000
1	Fuel tank	5-20, 5-35	▲			■				
2	Fuel filter	5-20, 5-38	■				●			
3	Engine oil	5-16, 19, 30, 31	▲	★	▲	●				
4	Engine oil filter	5-16, 5-31		★		●				
5	Engine coolant	5-21, 5-42	▲						●	
6	Radiator screen	5-23, 5-27	▲	■						
7	Air cleaner	5-22, 5-29, 5-40	▲	■				●		
8	Battery	5-29		▲						
9	Fan belt tension	5-34		▲ (First)		▲				
10	Valve clearance	5-41						▲		
11	EGR Cooler, PCV, Injector Tips	5-45							■	
12	Fuel injector, DOC&DPF, Turbocharger, ECU, etc	5-46								■
13	Hydraulic oil filter	5-16, 5-32		★		●				
14	Transmission oil	5-28, 5-37		▲			●			
15	Front axle oil	5-28, 5-36		▲			●			
16	Steering cylinder	5-27		▲						
17	Front axle holder & Steering arm	5-27		▲						
18	3-Point linkage	5-27		▲						
19	Clutch pedal play	5-25	▲							
20	Brake pedal play	5-26	▲							
21	Turn signal lights, Lights, Horn	5-21	▲							
22	Instrument panel & Indicators	5-20	▲							
23	Bolts and Nuts retighten	5-24	▲							
24	Tire air pressure	5-23	▲							
25	Toe-in	5-34				▲				
26	Cabin air filter	5-29, 5-39		■			●			
27	Hydraulic hoses	5-29		▲						
28	In-line pressure filter (EHL)	5-34		▲		●				

★ First Replacement   ● Replacement   ▲ Check, Adjustment and Supply   ■ Clean up



### 5-3. Lubricants and Capacity

LUBRICANTS	CAPACITY	INTERNATIONAL STANDARD	RECOMMENDED ITEMS
Engine coolant	<b>10 ℓ</b> (2.6U.S.gals)	ASTM D6210	Soft water (50%)+ Anti-freeze (50%)
Fuel	<b>100 ℓ</b> (26.4U.S.gals)	- ASTM D975-08a Grade 2 - EN590 : 2009 Diesel fuel - BS2869 : 2006 Class A2	Ultra low sulfur diesel fuel, below 15 ppm
Engine oil	<b>7.0 ℓ</b> (1.8U.S.gals)	API CJ-4, ACEA E3	KIXX DL (Maker : GS Caltex)
Transmission oil (Hydraulic lift, Steering)	<b>55 ℓ</b> (14.5U.S.gals)	API-GL4 ISO VG 32/46	<b>LSTH400G</b> (Maker : GS Caltex)
Front axle oil	<b>4.4 L</b> (1.2 U.S.gals) for center housing <b>0.6 L</b> (0.2 U.S.gals) for each final housing <b>=5.6 L</b> (1.5 U.S.gals)	API-GL4 SAE 80W	EPK 80W90 (Maker : S-OIL TOTAL Co. Ltd.)
Grease (Front axle holder, 3-point linkage)	Proper amount	NLGI 2	MAHWAK Multi purpose or MAHWAK All purpose (Caltex)
Clutch & Brake oil	<b>0.5 ℓ</b> (0.1U.S.gals)	Mineral based oil (ISO 7308)	LSTH400 (S-OIL TOTAL) LHM PLUS (TOTAL) LHM (Mobil) LHM-S (Shell)

#### RECOMMENDED ENGINE OIL VISCOSITIES

The correct engine oil viscosity grade is dependent upon ambient temperature. Refer to the below chart when selecting engine oil for your tractor.

In areas where prolonged periods of extreme temperatures are encountered, local lubricant practices are acceptable. Contact your authorized local dealer.

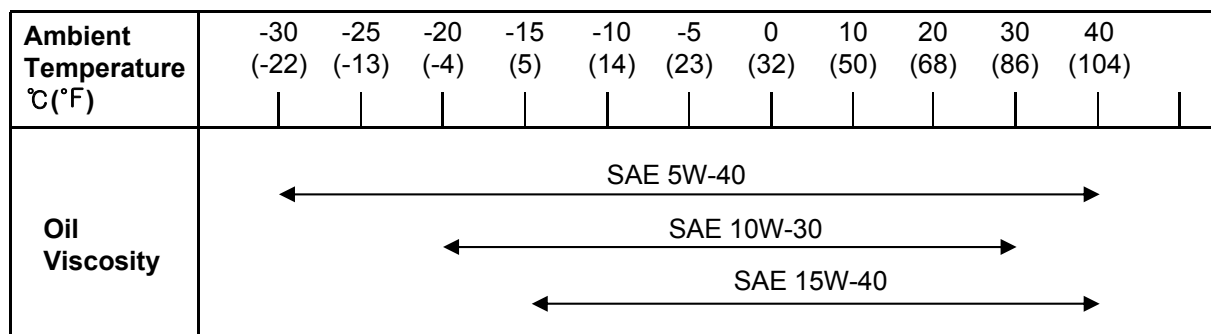

## 5-4. First 50 hour check



- After using first 50 hours, contact your authorized local dealer for maintenance if possible.
  - Replace engine oil & engine oil filter. (⇒ Refer to Every 300 hour check. See page 5-31)
  - Replace hydraulic oil filter. (⇒ Refer to Every 300 hour check. See page 5-32)
  - Replace power shuttle oil filter. (if fitted) (⇒ Refer to Every 300 hour check. See page 5-32)
  - Check transmission / rear axle / hydraulics oil level
  - Check front axle oil level
  - Check and adjust parking brake
  - Check torque of exhaust manifold bolts
  - Check and adjust V-belts and tension
  - Tighten all cooling system hose connections
  - Check torque of safety cab or frame mounting bolts
  - Check torque of front end weight clamp bolts (Where fitted)
  - Check torque of wheel bolts and nuts
  - Check tire pressures and condition
  - Clean radiator, oil cooler and A/C condenser cores (Where fitted)
  - Check radiator coolant level and specific gravity
  - Check clutch pedal free play (Mechanical synchro-shuttle models)
  - Check brake adjustment and pedal equalization
  - Lubricate all grease fittings
  - Neutral start switches operative (Where fitted)

## 5-5. When the warning indicator lights

### (1) Drain water from Fuel filter

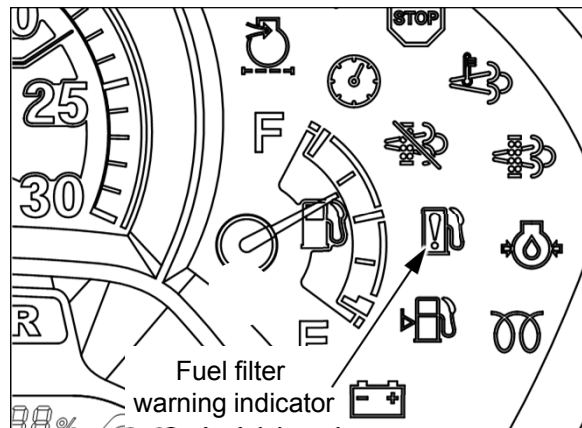
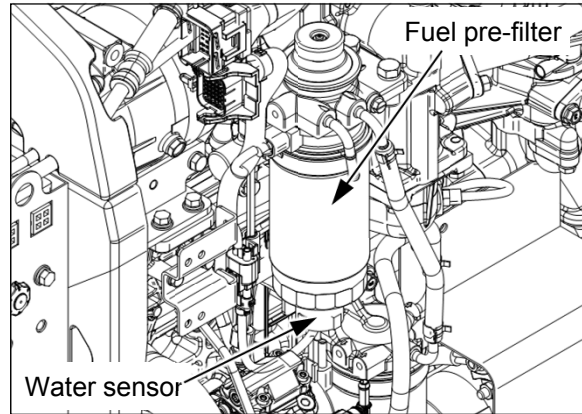
1. Disconnect the electric harness connector and loosen the water sensor under the fuel filter and drain water inside the filter.  
(Approx. 150cc(9.1 in<sup>3</sup>))
2. Tighten the water sensor and connect the electric harness connector.
3. Bleed air from the fuel filter. (See page 5-47)



 <p>Warning</p>	<p>▶ Fuel leaked or spilled onto hot surfaces or electrical components can cause a fire. To help prevent possible injury, turn the key switch off when changing fuel filters or water separator elements. Clean up fuel spills immediately.</p>
 <p>Caution</p>	<p>▶ Do not allow dirt to enter the fuel system. Thoroughly clean the area around a fuel system component that will be disconnected. Fit a suitable cover disconnected fuel system component. Do not fill the new filter with fuel. Invisible fine contaminants can enter the injection pump and it may cause damage to the fuel injection system.</p>
 <p>Caution</p>	<p>▶ Do not throw the exhausted waste fuel to any place. This may pollute the soil and water seriously and also is prohibited legally. If violating, you would be responsible for that by civil or criminal case. The waste oil must be disposed according to the environment laws.</p>

## (2) Engine oil pressure indicator

- This indicator① will be turned on when turning the key switch from “OFF” to “ON” position. After starting engine, this indicator must be turned off.
- If this indicator turns on while the engine is running, STOP THE ENGINE IMMEDIATELY.
- Check the engine oil level first, and if necessary, add new engine oil and recheck the indicator.
- If the engine oil level is normal, it means that there is a problem on the lubrication system, contact your authorized local dealer for check.

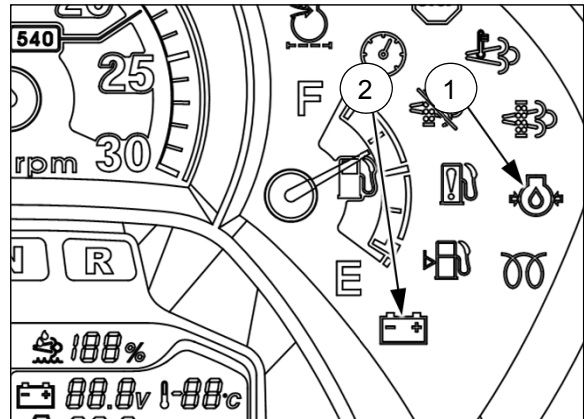

## (3) Battery charging indicator

- This indicator② will be turned on when turning the key switch from “OFF” to “ON” position. After starting engine, this indicator must be turned off.
- If this indicator turns on while engine is running, it means that there is a problem on the electric charging system.
- If the problem is not cleared, stop the engine and contact your authorized local dealer for check.

## 5-6. Check before starting (Daily check)

- Before starting engine, check the followings carefully to avoid any failure or damage.

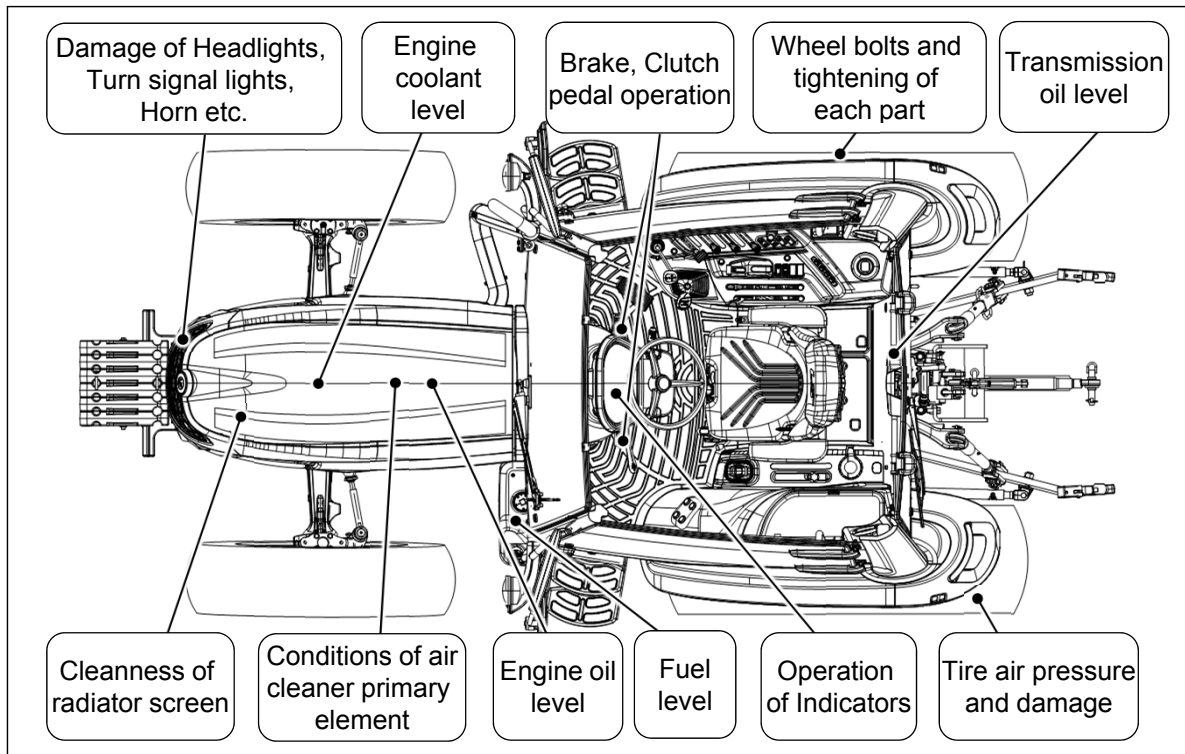

### (1) Engine oil

- **Oil specification and capacity :**

See chapter 5-3, "Lubricants and Capacity" or the last page in this manual.

- **Checking engine oil level**

- Check the engine oil level before starting engine or at 5 minutes later after stopping engine.
- Check if the oil level is between MAX and MIN marks of the oil gauge. If necessary, add new oil.
- It must only be checked while the engine is stopped.
- If your engine is operated in dusty/dirty condition, the service interval must be shorter than normal condition.
- Must replace the engine oil and engine oil filter after the first 50 hours of use.

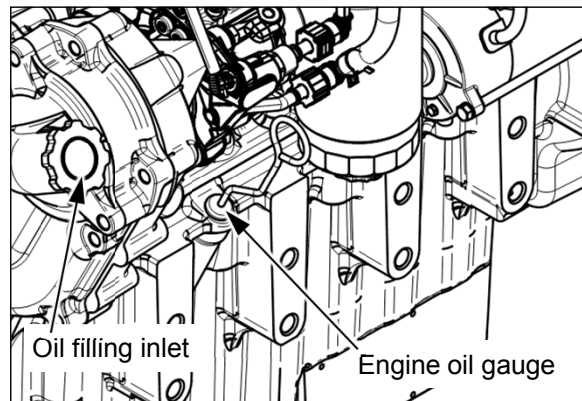

Engine oil gauge

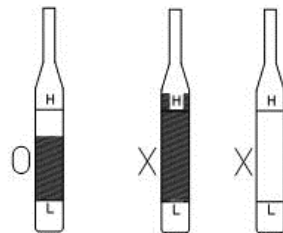

## (2) Fuel tank

### ① Fuel and Fuel tank Capacity:

- See chapter 5-3, "Lubricants and Capacity" or the last page in this manual.
- If contaminants like water or dusts are mixed in the fuel, it may cause a severe damage to the engine. The fuel storage facility must be equipped as shown in the right figure. If possible, fill the tank at the gas station with fuel.

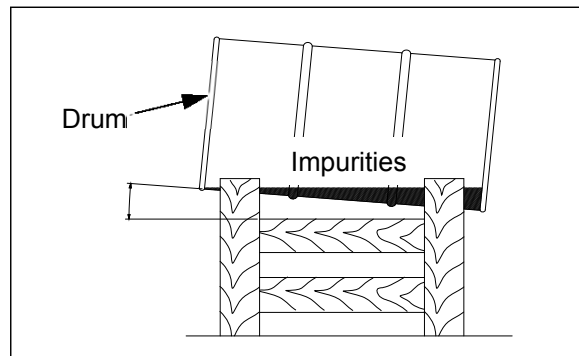

### ② Using Diesel for winter

- General diesel fuel tends to generate paraffin dregs in cold weather which may cause a bad engine start. Thus, it is recommended to use diesel for winter in cold weather.

### ③ Checking Fuel level and filling the tank

- Check the fuel gauge of the tractor fuel tank and if it's not sufficient, fill the fuel tank with diesel fuel. For further information about diesel fuel, see chapter 5-1-(3), 5-1-(4), 5-1-(5) in this manual.

Notice	▶ After finishing work, fill the fuel tank fully. As the temperature drops down at night, the humidity in the fuel tank is condensed, and may be mixed with the fuel.
--------	---

## (3) Instrument panel & Indicators

- Check if the indicators are normally turned on/off before starting engine or while operating frequently and periodically.
- If the **engine oil pressure indicator** and **battery charging indicator** are turned on while the engine is running, stop the engine immediately and check the engine lubrication system and battery charging system. If possible, contact your authorized local dealer for check.
- You must drain water in the fuel filter when the fuel filter warning indicator lights.
- For further information about indicators, refer to the chapter 3-1-(1), "Instrument panel" in this manual.

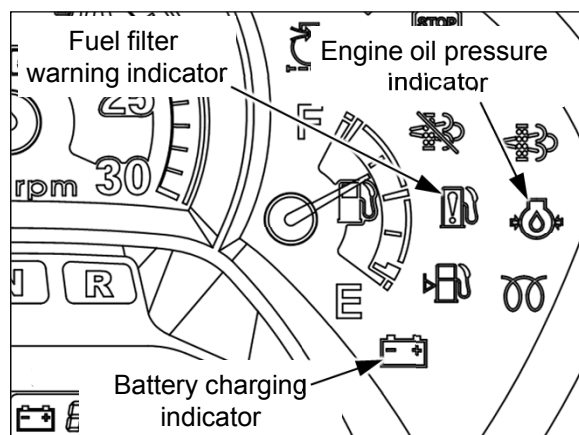

## (4) Turn signal lights, Lights, Horn

- Check the operational status of the headlights, turn signal lights, horn and other illuminating lights.
- If the light is OFF suddenly when operating the switch, check the problems as followings.
  1. Check the related fuse in the fuse box. See *chapter 5-14-(4), "Fuse & Main fuse" in this manual.*
  2. Check the light bulb. If damaged, replace it with a rated new one. See *below table and refer to the chapter 5-14-(7), 5-14-(8) in this manual.*

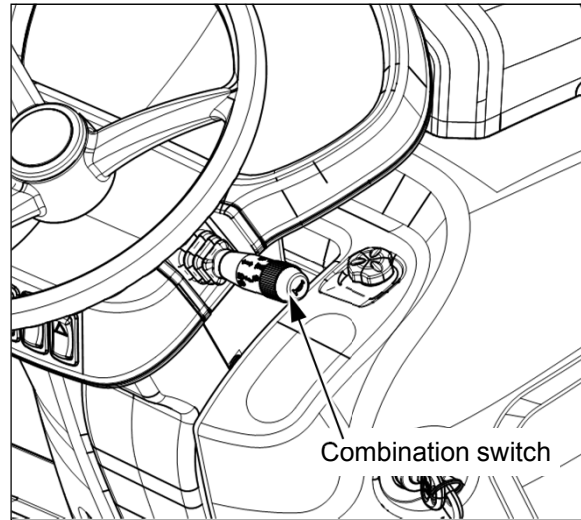

illuminating Lights	Light bulb specification
Head lights (Low beam / High beam)	12V 55W / 60W
Turn signal lights (front)	12V 16W
Side lights (front)	12V LED
Turn signal lights (rear)	12V 21W
Brake lights / Tail lights (rear)	12V LED / LED
Work lights	12V 27W(Grille) / 37.5W(Cabin)
Indoor light	12V 10W(Cabin only)
Instrument panel & indicators	LED

Notice	▶ Use the bulb of rated capacity. If using an improper bulb arbitrary, it may cause a failure of the electric system.
--------	---

## (5) Engine coolant

- Before opening the radiator cap, cool down the engine coolant sufficiently.
- Refer to the *chapter 5-12-(1), "Replacement of engine coolant" in this manual. (See page 5-42)*

## (6) Air cleaner (Dry type)

### ① Cleaning filter element

- If the air-cleaner service indicator in the instrument panel is turned on, make sure to check and/or clean the filter element regardless of recommended service intervals in this maintenance chart.
- Remove the cover and pull the primary element straight out, ensuring the safety filter element remains in place.
- When cleaning the element in the working field, tap the element by hand to remove the dust.

Notice	<ul style="list-style-type: none"><li>▶ Do not tap the element on a hard place when cleaning.</li><li>▶ If the element is cracked, change it with new one.</li></ul>
--------	--

- If the dust is not removed by tapping, use compressed air (less than 500kPa (5bar; 72psi)) from inside to outside as shown in the right figure to remove the dust and dirt. And clean inside the filter element with a clean damp cloth.

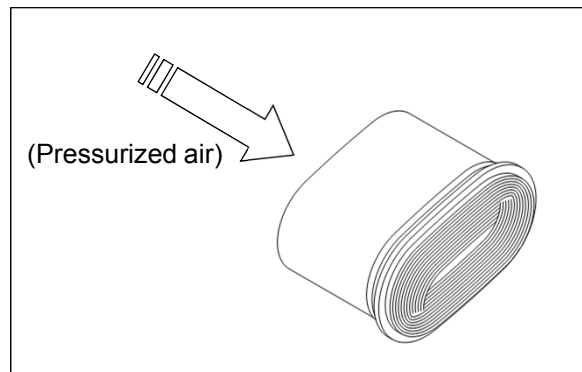
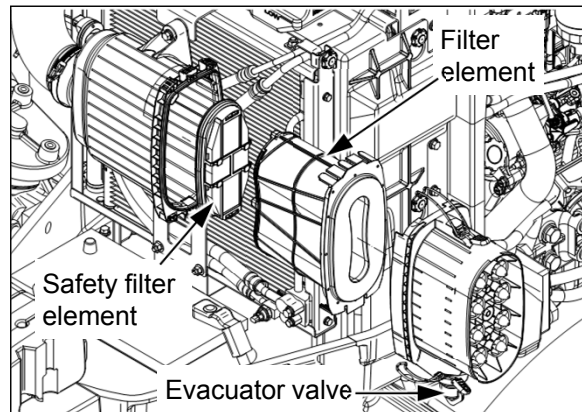

Notice	<ul style="list-style-type: none"><li>▶ Do not assemble a wet filter element.</li><li>▶ Do not dry the wet filter element with compressed air. It may cause damage to the filter element.</li><li>▶ Do not start the engine or close the hood if the filter element is not assembled.</li></ul>
--------	---

### ② Assembling filter element

- Clean the inside of the air cleaner housing using a clean damp cloth, being careful not to damage the safety element.
- Check if there is damage inside the filter element by using a light. If there is tiny crack or small hole in the filter element or the gasket is damaged, replace it with a new one.
- Insert the filter element deeply into the filter housing.
- Remove the dust of the evacuator valve and clean the inside of the cover.
- Assemble the cover with the evacuator valve facing downwards.



## (7) Cleaning of Radiator and Radiator screen

- Inspect the radiator and radiator screen for these items on a daily basis: Damaged fins, corrosion, dirt, grease, insects, leaves, oil, and other debris. Clean the radiator and radiator screen, if necessary.
- To access the engine radiator, remove the knobs and pull out the radiator screen.
- When cleaning the radiator with water, let the water flow from the fan side.
- When cleaning the radiator, check and clean the condenser, TM oil cooler and other radiators together.

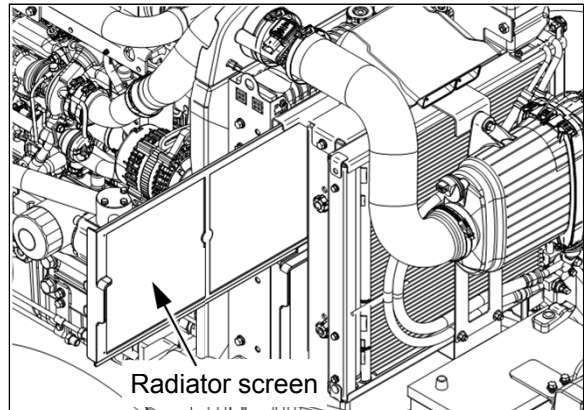



 <b>Caution</b>	<ul style="list-style-type: none"> <li>▶ The dust and dirt, other debris, and damaged fins can cause that cooling efficiency of the radiator is reduced and the engine can be overheated.</li> <li>▶ Clean the radiator only after stopping engine.</li> <li>▶ If cleaning with water, take care not to spray water to the electric and electronic parts. If possible, DO NOT USE WATER.</li> </ul>
--	---

## (8) Tire air pressure and damage

### ① Check

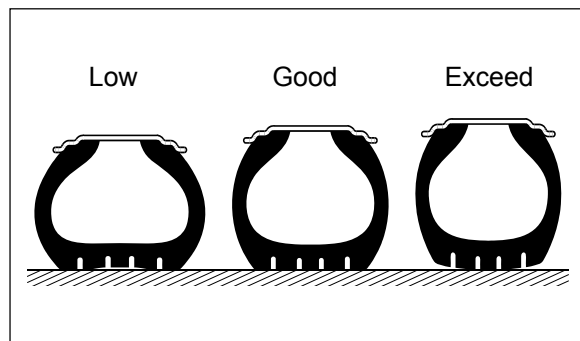
- Check the tire air pressure or damage of the tires on a daily basis. Always use the correct pressure for each axle, and if the tire is damaged, change it with a new one.
- Ensure the tire air pressures are not lower than the correct values, to prevent;
  - blown tires;
  - bead wear;
  - internal damage;
  - irregular wear and short service life.
- Do not over-inflate the tires, as this may cause to damage in the event of impact and, in extreme conditions, the rim and disk may be deformed or the tires may burst.



 <b>Caution</b>	<ul style="list-style-type: none"> <li>▶ Do not assemble/disassemble the tires arbitrarily. Only qualified service personnel should perform this maintenance in a tire repair center equipped with special tools.</li> <li>▶ When checking tire air pressure, keep the body away from the valve mechanism or cap. Tire air pressure vary depending on the load weighing on the axles.</li> </ul>
--	--

- ② **Standard air pressure** - See chapter 4-5-(5), "Tires and Load capacity" in this manual.

## (9) Tightening state of bolts and nuts of each part

- Check if the bolts or nuts of each part are loosened. If necessary, tighten it again. Especially, check the bolts and nuts of the tires before starting engine, if necessary, tighten them.

 Warning	<p>▶ <b>Roll-over hazard!</b></p> <p><b>Never operate the machine with a loose wheel rim or disc. Always tighten nuts and/or bolts to the specified torque value and at the recommended intervals.</b></p> <p><b>Failure to comply could result in death or serious injury.</b></p>
---	---

Tighten the wheel bolts and nuts to the specified torque any time you remove the wheel assembly from the machine or loosen the wheel bolts or nuts.

**Front Wheel Torque: M18x1.5P**  
**2500~2800 kgf.cm**  
**(245~275 N.m, 181~203 lb.ft)**

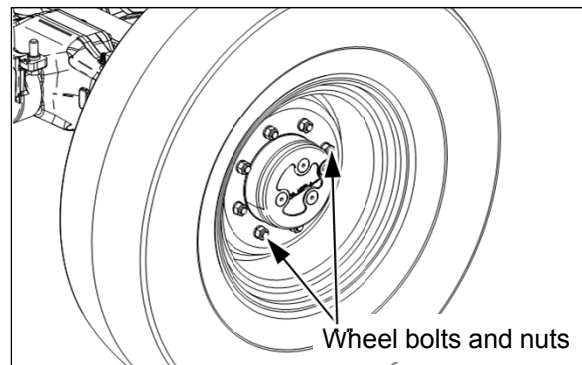

**Rear Wheel Torque: M18x1.5P**  
**2500~2800 kgf.cm**  
**(245~275 N.m, 181~203 lb.ft)**

**NOTICE:** Check and tighten wheel bolts and nuts to proper torque specifications after the following hours of use:

- First 5 hours
- First 50 hours
- Every 300 hours

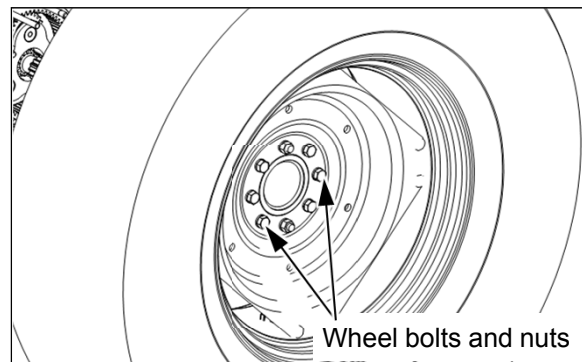

## (10) Adjustment of Clutch pedal play

### ① Synchro-shuttle (Mechanical)

- **Normal distance: 20~40mm (0.8~1.6 in.)**

If the distance is over the normal distance, adjust it as below.

1. Loosen locking nut and turn the clutch rod clockwise / counter-clockwise.
  2. If tightening the clutch rod, the pedal play shall be increased, and if loosening, it shall be decreased.
  3. Pay attention that the clutch rod does NOT push the piston of clutch master cylinder when the clutch pedal is released.
  4. After adjusting the pedal play, tighten the locking nut.
  5. Check if the clutch is disengaged completely.
- If you need more adjustment for clutch pedal play, check the oil level and bleed air from the clutch pedal oil line. (See page 5-50)

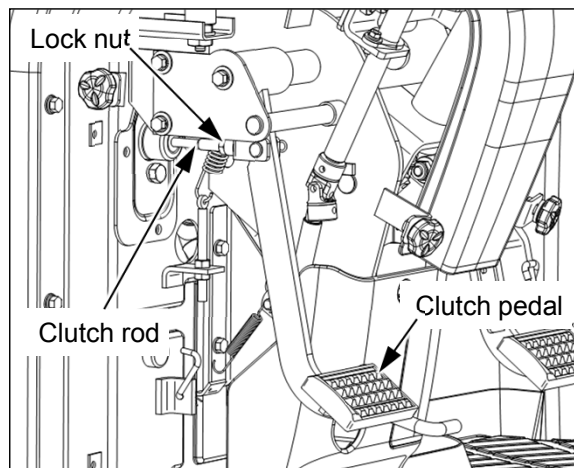

### ② Power shuttle (PSS)

- In case of power shuttle models, an electric sensor to control the power shuttle clutch pack is attached and tuned specially on the clutch pedal linkage system.  
If this linkage system is changed or modified arbitrary, it may cause a serious fault or malfunction to the power shuttle clutch pack.
- The air-bleeding of the power shuttle clutch pedal system is NOT needed.
- If you need any service for power shuttle system, do not hesitate to contact your authorized local dealer for check.

## (11) Adjustment of Brake pedal play

- **Normal distance: 20~40mm. (0.7~1.6 in.)**

If the pedal play distance is over the normal distance, adjust it as below.

1. Loosen the locking nut and turn the brake rod clockwise / counter-clockwise.
2. If tightening the brake rod, the pedal play will be increased, and if loosening, it will be reduced.
3. Pay attention that the brake rod does NOT push the piston of brake master cylinder when the brake pedals are released.
4. After adjusting the pedal play, tighten the locking nuts.
5. Check if the brake distance of the left and right brake is same as below.

- Also, be sure to check the brake pedal force. When you press the brake pedal(s), if you feel the brake pedal(s) falls into the swamp, it means a possibility that some air bubbles are in the brake oil line. Consult your authorized local dealer for bleeding air from the brake oil line. (For the details, see page 5-50)

- **Checking the brake distance**

1. Connect the left and right brake pedal with the brake pedal latch.
2. Check the skid marks of the tires or stability of the tractor while driving at a suitable speed.
3. If the brake distance is different as shown in the right figure, adjust the pedal play again.
4. If the vehicle is turned to the left-hand side when checking the braking distance, tighten the left-hand brake rod or loosen the right-hand brake rod with checking the brake pedal play distance.

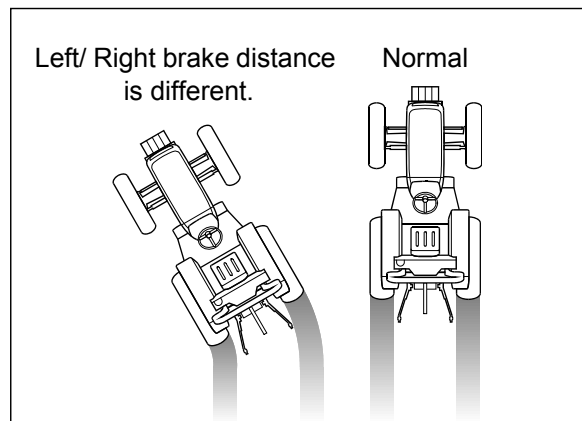
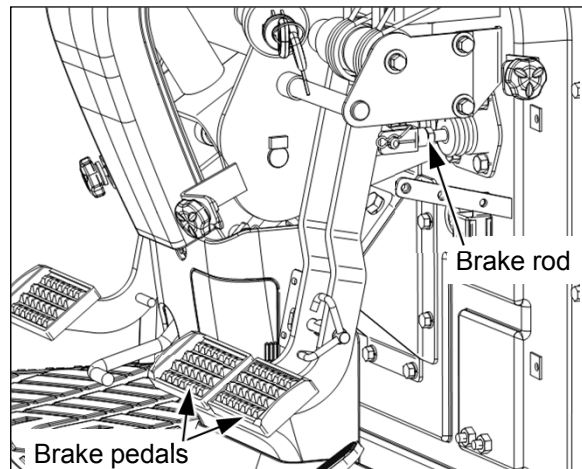

## 5-7. Every 50 hour check

### (1) Lubricating grease nipple

- Steering cylinder pins (LH/RH)
- Front axle holder & Steering arm (LH/RH)
- 3-point linkage

1. Wipe dirt from fittings before greasing.

2. Use a grease gun containing clean high grade of grease.

*For grease specification, see chapter 5-3, "Lubricants and Capacity" or the last page in this manual.*

3. Pump fresh grease into fitting to adequately lubricate the component and force out any contamination from the grease passage.

4. Wipe off excess grease.

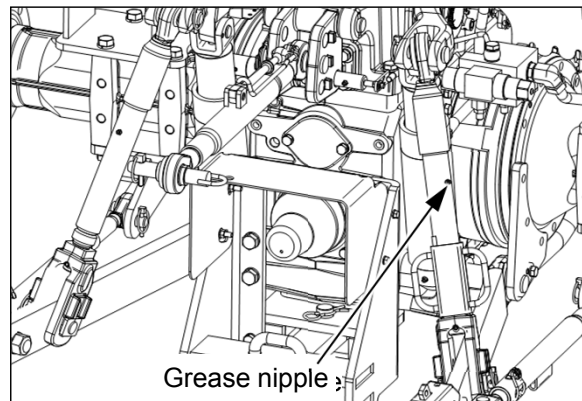
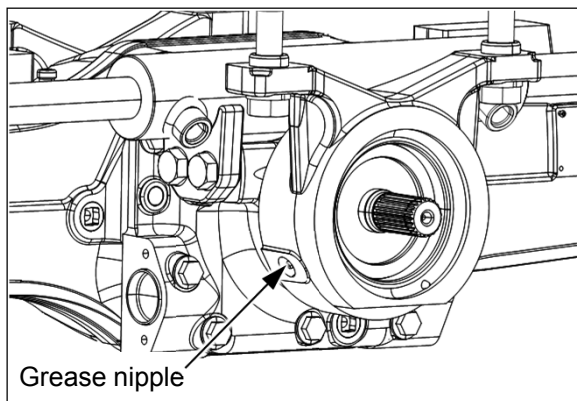
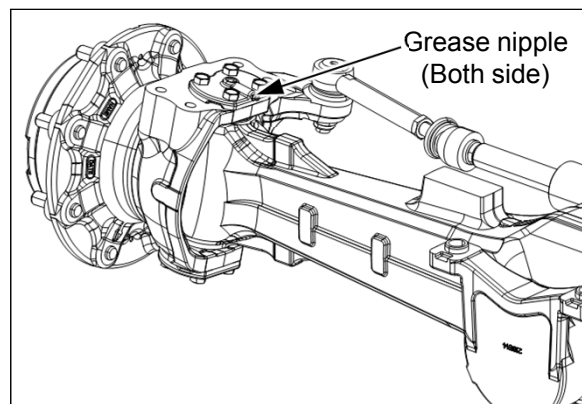
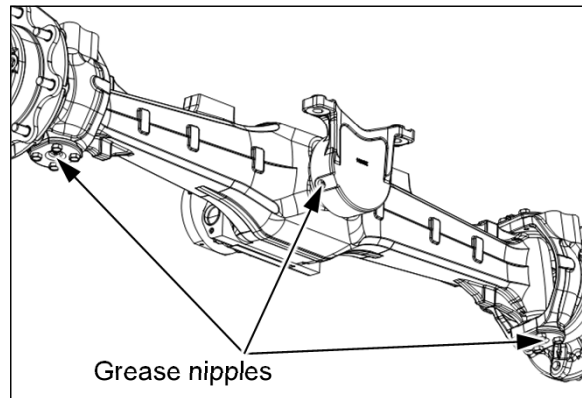



### (2) Cleaning Radiator and Radiator screen

- See chapter 5-6-(7) in this manual. (See page 5-23 )

### (3) Checking Transmission oil

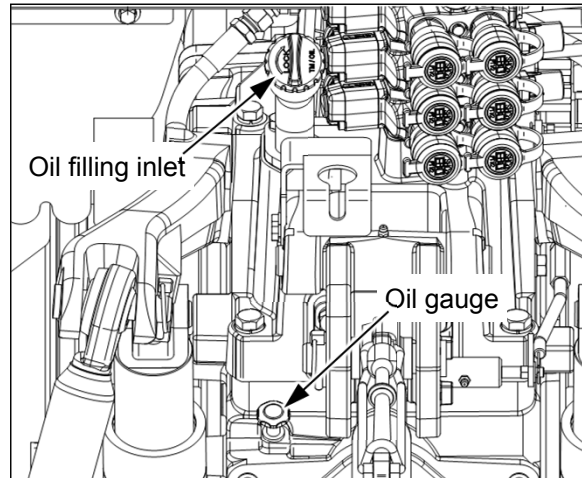
- Stop the tractor on a level surface and apply the parking brake and lower implements to the ground.
- Clean around oil filling inlet and pull the gauge straight out.
- Check If the oil level is between MIN and MAX mark of oil gauge. If not, add new oil.
- For oil specification, see chapter 5-3, "Lubricants and Capacity" or the last page in this manual.



 <b>Caution</b>	<p>▶ The contaminated oil may reduce the durability of the power drive line and it can cause failure of the transmission and hydraulic system. Clean around the oil filling inlet before opening the gauge.</p>
--	---

### (4) Checking Front axle oil

#### ① Center housing

- Park the tractor on a level surface.
- Open the oil check port plug and be sure to check if the oil level is full.
- If necessary, add new oil into the oil filling inlet. (after 5~10 minutes later, check the oil level again)
- Tighten the oil check port plug.
- For oil specification, see chapter 5-3, "Lubricants and Capacity" or the last page in this manual.

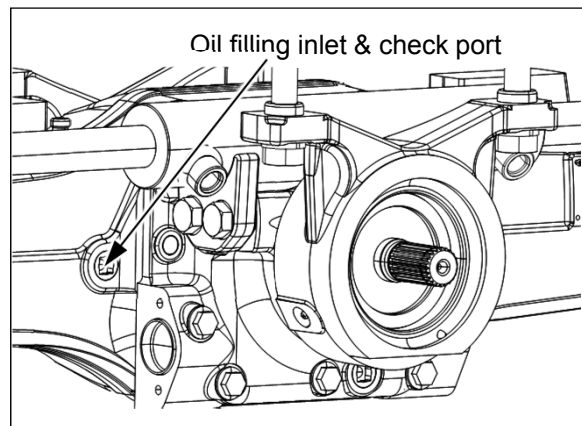

#### ② Final gear case

- Place the oil check port horizontally.
- Open the oil check port plug and be sure to check if the oil level is full. If necessary, add new oil into the oil filling inlet.
- Tighten the oil check port plug, and check the oil level on the other side.
- For oil specification, see chapter 5-3, "Lubricants and Capacity" or the last page in this manual.

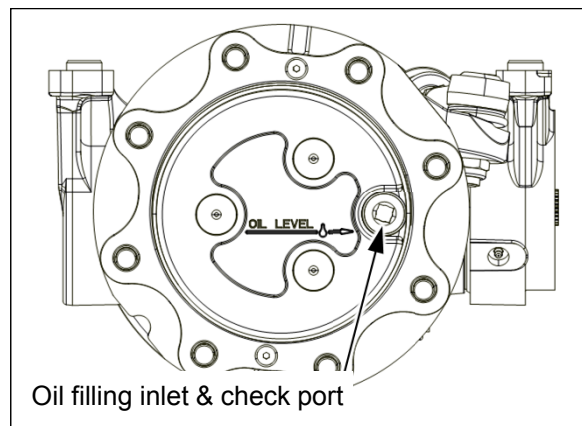

## (5) Battery check

- Refer to the chapter 5-14-(5), “Batter handling and Notices” in this manual. (See page 5-54)

## (6) Air cleaner (Dry type)

- Refer to the chapter 5-6-(6) in this manual (See page 5-22).

## (7) Hydraulic hoses and Leakage

- Stop the engine and place all the transmission gears in neutral and lower down the implement to the ground.
- Periodically check the hydraulic system for leaks or damaged parts - kinked, crushed, flattened, hard blistered, heat cracked, charred, twisted, soft or loose covered hoses and fittings.
- Before removing hydraulic components, make sure to check that the hydraulic pressure is relieved completely. The leaks of pressurized oil can cause a fatal physical injury.

For further information, see chapter 3-5.  
“Hydraulic system” in this manual.

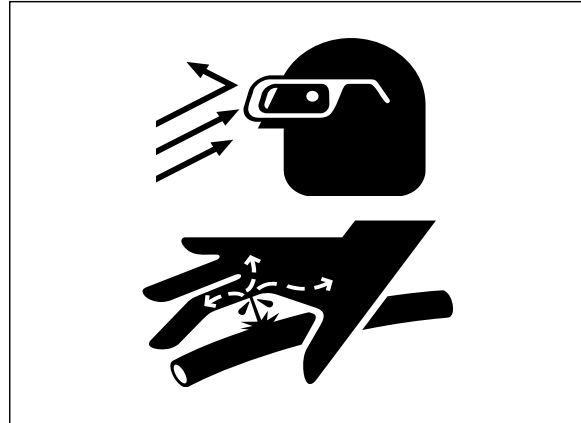

## (8) Cleaning Cabin air filters

- Before servicing the filters, switch off the blower and close all the cabin doors and windows.
- Unscrew the knobs under the roof and remove the cover and filter element as shown in the right figure.
- Clean the elements by blowing with compressed air not exceeding 30psi (2bar). Blow the dust from the upper surface through the element to the underside. Hold the nozzle at least 12 in. (300mm) from the element to prevent damage to the filter media.
- Clean all filter chambers with a damp, lint-free cloth. Re-install the filter elements.
- Re-install the filter cover and tighten the knobs.

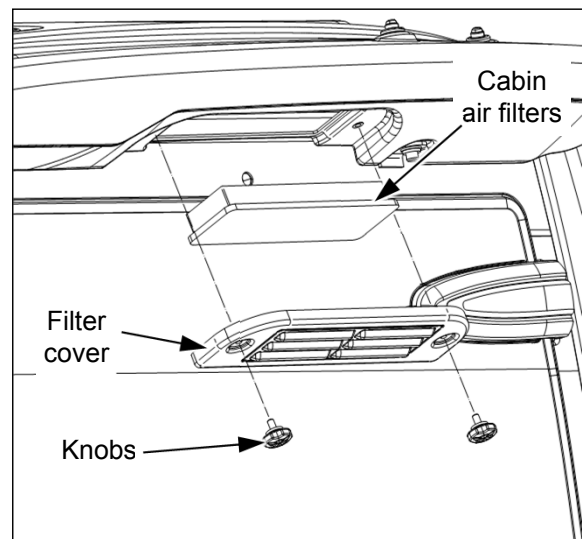

### Notice

- ▶ The filters are made of specially treated media with a rubber sealing strip bonded around the sides. Take care not to damage the element during installation.

## 5-8. Every 100 hour check

### (1) Checking and adding Engine oil

- **Oil specification and capacity:**  
*See chapter 5-3, "Lubricants and Capacity" or the last page in this manual.*
- **Checking engine oil level**
  - Check and add the engine oil **every 100 hours of operation**.
  - Check it before starting engine or at 5 minutes later after stopping engine.
  - It must only be checked while the engine is stopped.
  - Check if the oil level is between MAX and MIN marks of the engine oil gauge. **If the engine oil level is under the minimum mark, add new engine oil up to the maximum mark as much as possible.**
  - If your engine is operated in dusty/dirty conditions, the service interval must be shorter than normal condition.

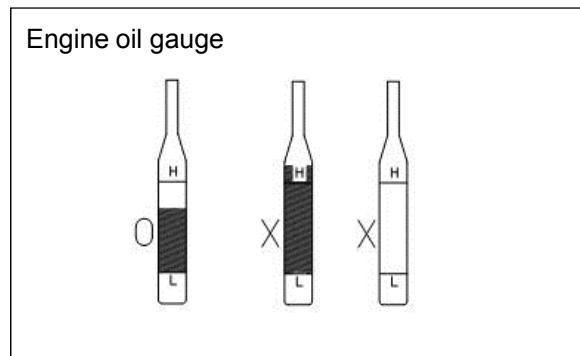
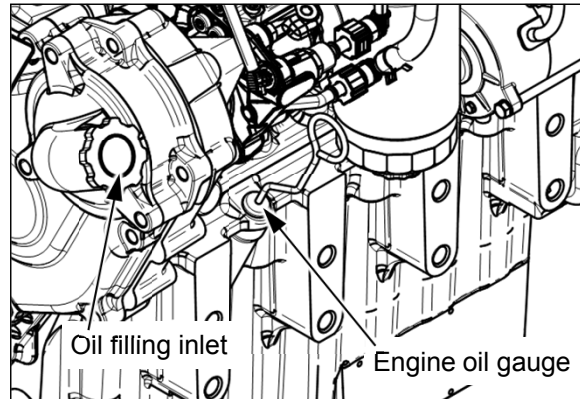

- ▶ The amount of engine oil consumed may vary depending on the operating conditions. Check the amount of engine oil regularly and if necessary add new engine oil. Otherwise, the engine can be stuck or broken by engine oil shortage.



## 5-9. Every 300 hour check

### (1) Replacing Engine oil and Filter

#### ① Drain Engine oil

- Run engine for a few minutes to warm oil.
- Park the tractor on a level surface.
- Remove both LH and RH drain plugs of oil pan and drain the oil completely.

<b>Notice</b>	▶ When engine oil is warm, the impurities can be drained completely.
---------------	--

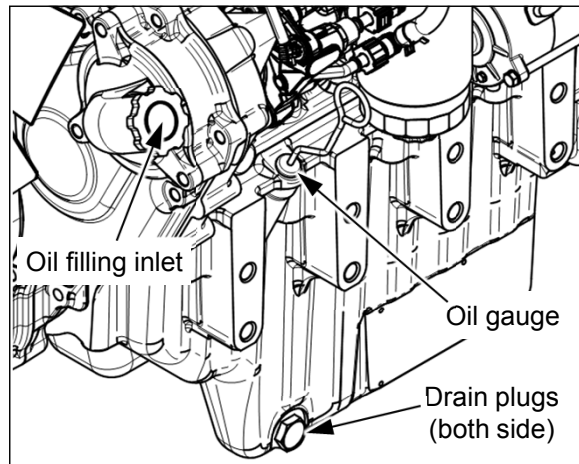

#### ② Replace Engine oil filter

- Clean carefully around the filter.
- Coat clean engine oil on the packing of new filter and check the packing is placed well in the groove.
- Turn the oil filter counter-clockwise to remove it with filter wrench.
- Turn the new filter clockwise to assemble it until the packing makes contact with the mounting surface. Tighten  $\frac{3}{4}$  to 1 turn more after packing contact.
- If the metal is attached to the element of oil filter to be disassembled, contact your authorized local dealer.

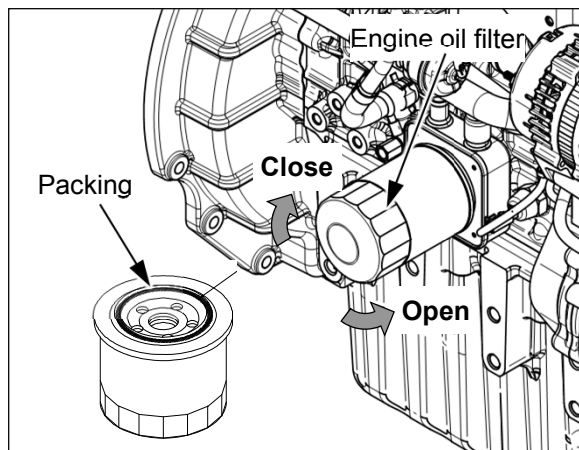

#### ③ Fill Engine oil

- Tighten all the drain plugs. (Tightening torque :  $40 \pm 5$  N.m) ( $29.5 \pm 5$  lbs-ft)
- Add new engine oil and check the oil level is between MIN and MAX marks on the gauge.
- *For oil specification, see chapter 5-3, "Lubricants and Capacity" or the last page in this manual.*
- Check any leakage of the engine while running the engine for several minutes at idle rpm.
- Stop the engine. After about 5~10 minutes later, check again if the oil level is between MIN and MAX marks. Install the oil gauge.

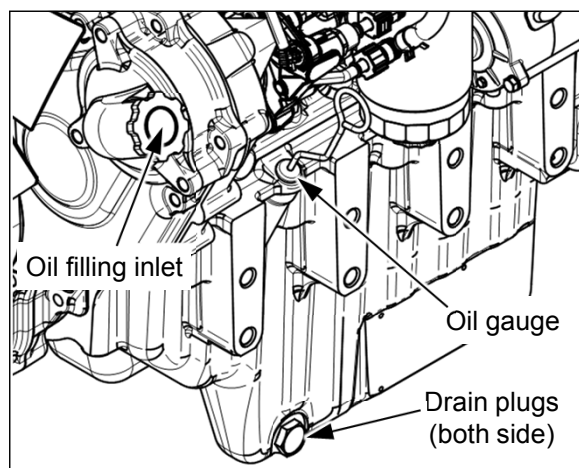

## (2) Replacing Hydraulic Oil Filter

- Park tractor on level surface and apply parking brake and lower implements and stop the engine.
- This filter is attached under the right-hand floor.
- Carefully clean around the filter and set a clean container under the filter.
- Coat clean hydraulic oil on the packing of new filter and check the packing is placed well in the groove.
- Turn the oil filter counter-clock wise to remove with filter wrench.
- Turn the new filter clockwise to assemble until the packing makes contact with the mounting surface. Tighten  $\frac{3}{4}$  to 1 turn more after packing contact.
- Run the engine at idle and check any leakage.
- Check the oil level. If necessary, add new oil. *For oil specification, see chapter 5-3, "Lubricants and Capacity" or the last page in this manual.*

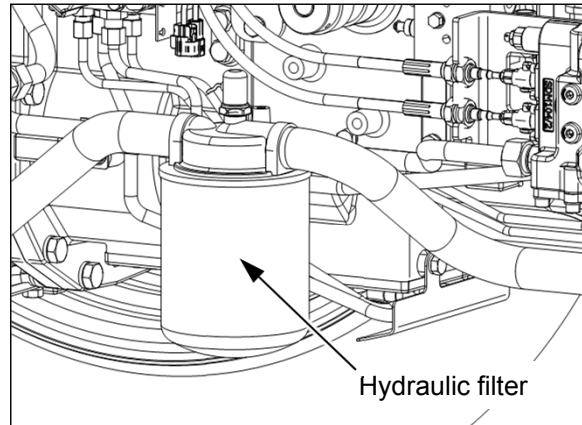

### Warning



- ▶ Be sure to stop the engine before loosening the oil filter.
- ▶ If the filter or oil is very hot, it may cause serious burns. After cooling down the tractor sufficiently, replace the filters.
- ▶ Do not throw the exhausted waste oil to any place. This may pollute the soil and water seriously and also is prohibited legally. If violating, you would be responsible for that by civil or criminal case.

## (3) Replacing Power shuttle oil filter (if fitted)

- This filter is attached under the right-hand step floor of the power shuttle models.
- Replace this filter with a new one to the same as procedure of the hydraulic oil filter.

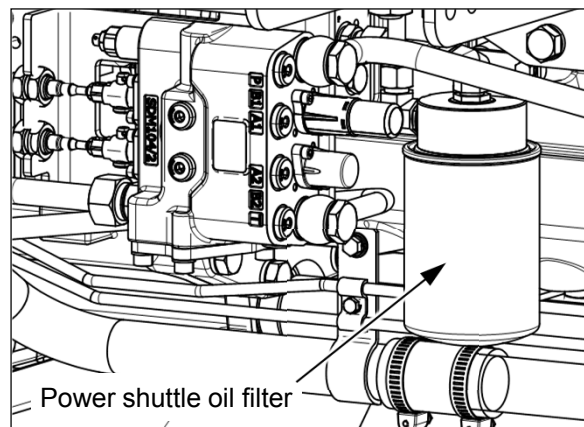

### Warning

- ▶ If the filter or oil is very hot, it may cause serious burns. After cooling down the tractor sufficiently, replace the filter. Do not loosen the filter while engine is running.

## (4) Checking Brake oil

- Open the bonnet and check the brake oil level. If the oil level is between “MAX” and “MIN” marks, it means “Proper amount”. If necessary, add new brake oil.
- Make sure to check the specification, before adding new oil.  
*For oil specification, see chapter 5-3, “Lubricants and Capacity” or the last page in this manual.*
- If the oil is discolored or contaminants are mixed, replace the oil with new one.
- After changing oil, bleed the air from the brake and clutch line. If possible, contact your authorized local dealer.

*(For further information, see page 5-50.)*

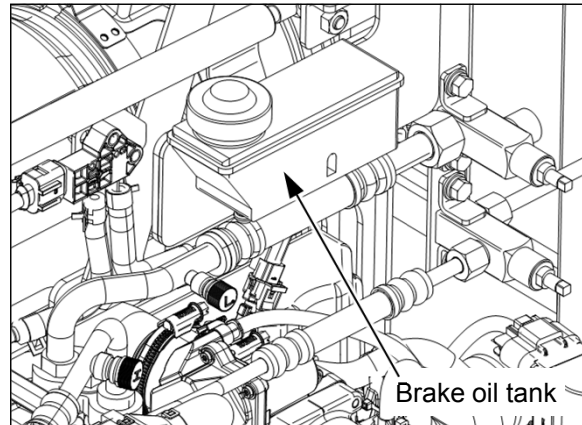

 <b>Warning</b>	<ul style="list-style-type: none"><li>▶ If any part of clutch or brake line is replaced or the oil is changed, execute air-bleeding. Air in the brake and clutch line can cause serious faults of the brake and clutch operation and fatal physical injury.</li><li>▶ If the specific oil is not used, even though a little amount, it can cause serious faults of the clutch and brake devices. In this case, all of brake and clutch device must be serviced. Contact your authorized local dealer.</li><li>▶ If the engine is very hot, it may cause serious burns. After the engine is cooled down sufficiently, check the brake oil level.</li></ul>
--	---

## (5) Tension adjustment of Fan belt

- If the tension of fan belt exceeds the normal value, loosen the bolts and adjust the tension.
  - Belt tension: crank shaft pulley ~ alternator pulley
  - **Normal : approx. 10~12mm (0.4~0.5 in.)**  
**(When pressed by 98N (22 lb))**
- When adjusting the tension,
  1. Loosen two bolts of alternator and a hinge bolt of the adjusting plate, and insert a bar between crank case and alternator.
  2. Pull and hold the bar to apply proper tension to the belt, tighten the upper bolt of the alternator.
  3. If the belt tension becomes normal, tighten the other bolts and check the tightening torque.

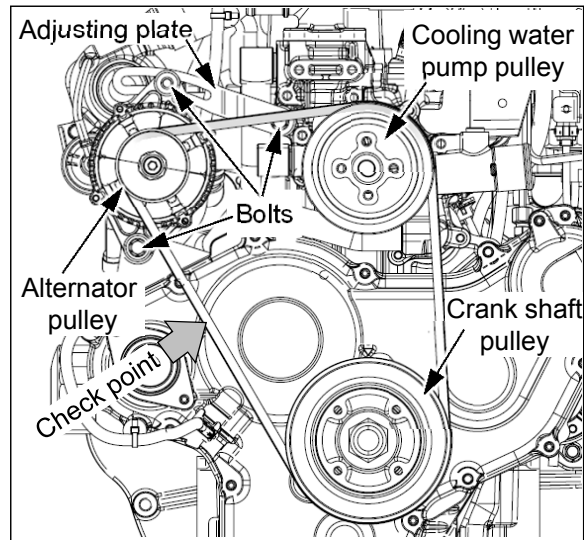

## (6) Toe-in

- Check and adjust the toe-in of the front wheels and if needed, adjust it as below.
  - Normal value :  $B - A = 0 \sim 5 \text{ mm}$  (0~0.2 in.)**
- Loosen lock nut of the tie-rod (both side).
- Fix steering cylinder and turn adjuster counter-clockwise, the toe-in ("B-A") shall be increased.
- Turn adjuster of the other side to the same displacement.
- After adjusting the toe-in, tighten the lock-nuts.
- If possible, contact your authorized local dealer.

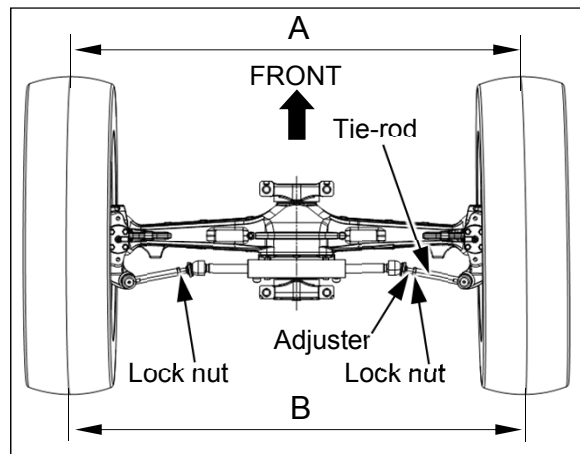

## (7) In-line pressure filter (if fitted)

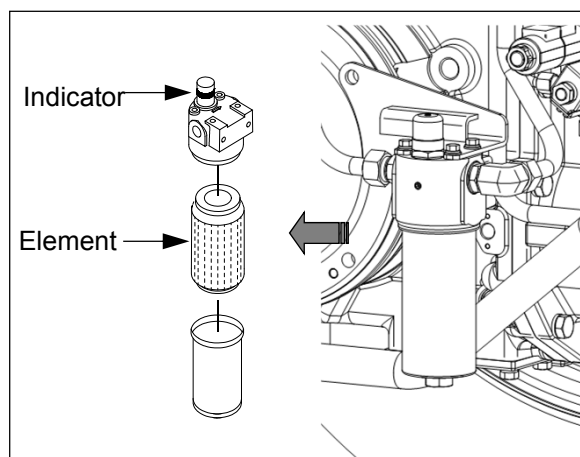

- If this in-line pressure filter is clogged, the automatic leveling control or electro-hydraulic lift (EHL) may not be operated smoothly.
- This filter is located in front of the right rear axle housing.
- If the indicator installed on the filter housing is changed from green color to red color, replace the element with a new one.

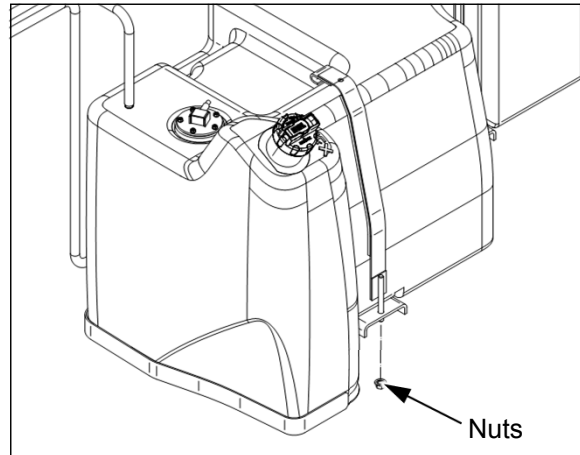

## (8) Cleaning fuel tank

- The contaminants like dusts, water and sediments in fuel tank shall cause to malfunction of the fuel injection system.
- Clean fuel tank periodically.
- The fuel tank is very heavy. Cooperate with other people to lift up/down the fuel tank after loosening nuts in the right figure.
- Use clean diesel or approved detergent by manufacturer to clean inside the fuel tank.



<p> Warning</p>	<p><b>Heavy parts!</b></p> <p>▶ The fuel tank is very heavy. When removing/attaching the fuel tank, please be careful and cooperate with other people, and use suitable equipment to move the heavy part. Failure to comply could result in death or serious injury.</p>
<p> Caution</p>	<p>▶ Do not allow dirt to enter the fuel system. Thoroughly clean the area around a fuel system component that will be disconnected. Fit a suitable cover disconnected fuel system component.</p> <p>▶ Do not throw the exhausted waste fuel to any place. This may pollute the soil and water seriously and also is prohibited legally. If violating, you would be responsible for that by civil or criminal case. The waste oil must be disposed according to the environment laws.</p>

## 5-10. Every 500 hour check

### (1) Changing Front axle oil

#### ① Center housing

- Stop the tractor on a level surface and apply parking brake.
- Clean air-breather and the surrounding area.
- Set a container under the drain plug.
- Remove oil filling inlet plug first, and drain plug.
- Drain oil completely, and clean with care and tighten the drain plug.
- Add new oil into the oil filling inlet with checking if the oil flows out through the oil check port.
- Clean with care and tighten the oil check port plug.
- *For oil specification, see chapter 5-3, "Lubricants and Capacity" or the last page in this manual.*

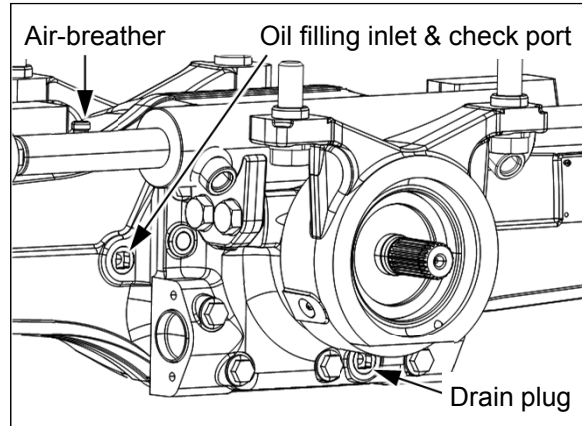

#### ② Final gear cases

- Stop the tractor on a level surface and apply parking brake.
- Set a container under the oil plug of the final gear case.
- Before draining oil, rotate the wheel end so that the oil plug is at the highest position.
- Partially unscrew the oil plug to release possible pressure.
- Place the oil plug downward and remove the oil plug. Drain oil completely.
- Add new oil into the oil filling inlet with checking if the oil flows out through the oil check port.
- If necessary, wrap the sealing tape on the oil plug, and tighten the oil plug.
- *For oil specification, see chapter 5-3, "Lubricants and Capacity" or the last page in this manual.*

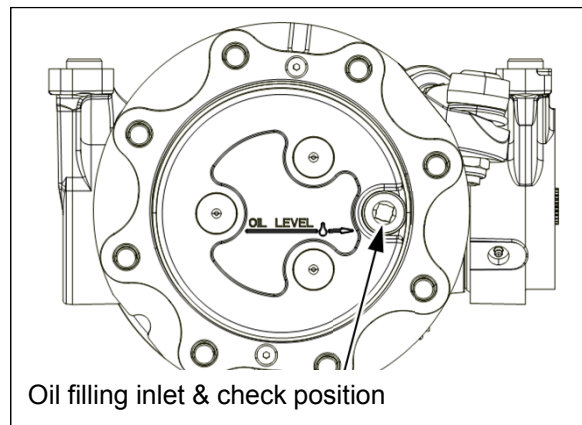
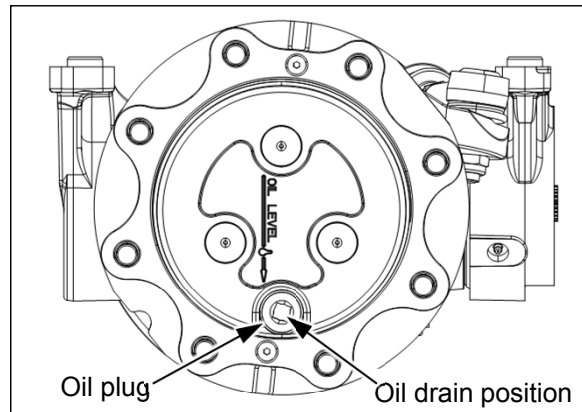



Caution

- ▶ Before draining oil, partially unscrew the oil plug to release possible pressure at the highest position of the oil plug.

## (2) Changing Transmission oil

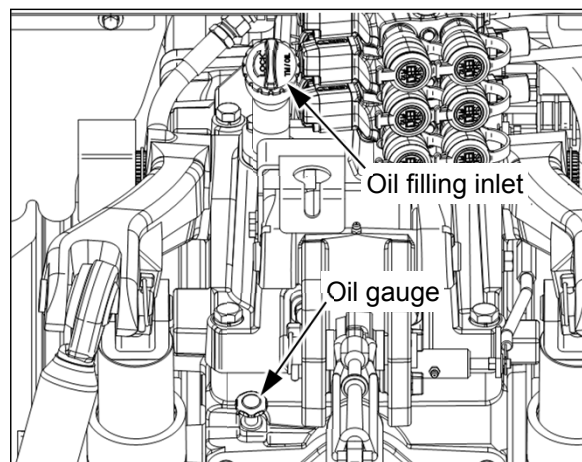
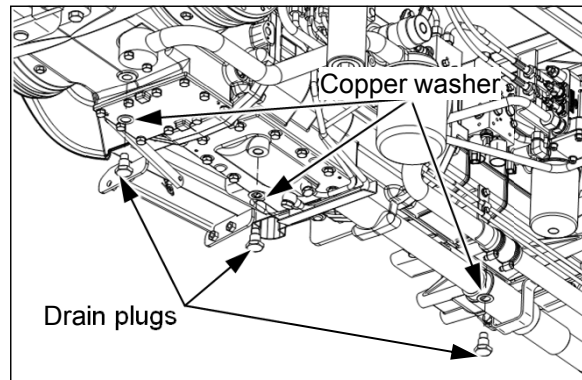
- Stop tractor on a level surface and apply parking brake. Run engine for several minutes to warm oil and lower implements and stop the engine.
- Set container under drain plugs and remove the drain plugs under the transmission and drain oil completely.
- Remove metal sludge stuck to drain plugs and tighten the drain plugs again with copper washer.
- Add new oil until the oil level is between MIN and MAX of the oil gauge.
- *For oil specification, see chapter 5-3, "Lubricants and Capacity" or the last page in this manual.*



 Caution	▶ The contaminated oil may reduce the durability of transmission and cause the failure of hydraulic system. Clean around oil filling inlet and oil gauge before opening.
---	--

### (3) Replacing Fuel filter cartridge

#### ① Pre-fuel filter

- Stop the engine and cool it down sufficiently. Set a clean container under the pre-fuel filter.
- Disconnect the electric harness connector of the fuel filter sensor and loosen the fuel filter sensor with collecting the fuel well.
- Remove the filter element from the body.
- Assemble the fuel filter sensor to the new element.
- Install the new element assembly to the body.
- Connect the electric wire connector of the fuel filter sensor.
- Bleed air from the fuel filter. *See chapter 5-14-(1), "Air-bleeding from fuel system" in this manual.*

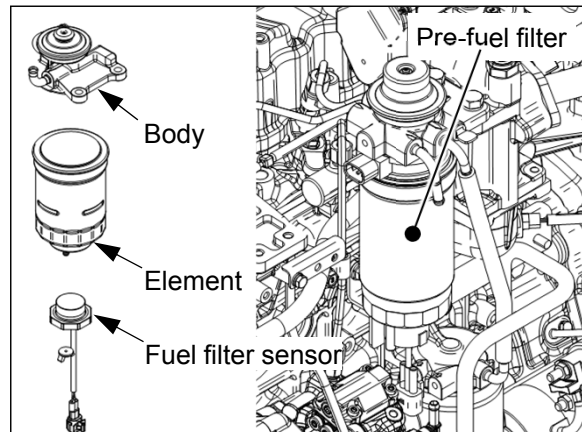

#### ② Main fuel filter

- Apply parking brake and set a container under the main fuel filter.
- Turn the filter counter-clockwise to remove with using a filter wrench.
- Coat the seal of new filter with a little fuel.
- Assemble new filter.
- Bleed the air from the main fuel filter. *(Refer to the chapter 5-14-1, "Air-bleeding from fuel system" in this manual. )*

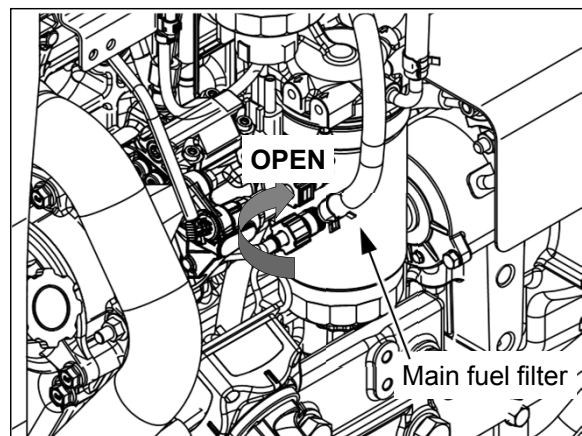

 <b>Warning</b>	<p>▶ Fuel leaked or spilled onto hot surfaces or electrical components can cause a fire. To help prevent possible injury, turn the key switch off when changing fuel filters or water separator elements. Clean up fuel spills immediately.</p>
--	---

 <b>Caution</b>	<p>▶ Do not allow dirt to enter the fuel system. Thoroughly clean the area around a fuel system component that will be disconnected. Fit a suitable cover disconnected fuel system component. Do not fill the new filter with fuel. Invisible fine contaminants can enter the injection pump and it may cause damage to the fuel injection system.</p>
--	--



## (4) Replacing Cabin air filters

- Before servicing the filters, switch off the blower and close all the cabin doors and windows.
- Cabin air filters are installed on the left and right-hand side under the cabin roof.
- Unscrew the knobs under the roof and remove the covers and filter elements as shown in the right figure.
- Clean both filter chambers with a damp, lint-free cloth.
- Replace the cabin air filters with a new one.
- Re-install the filter covers and tighten the knobs.

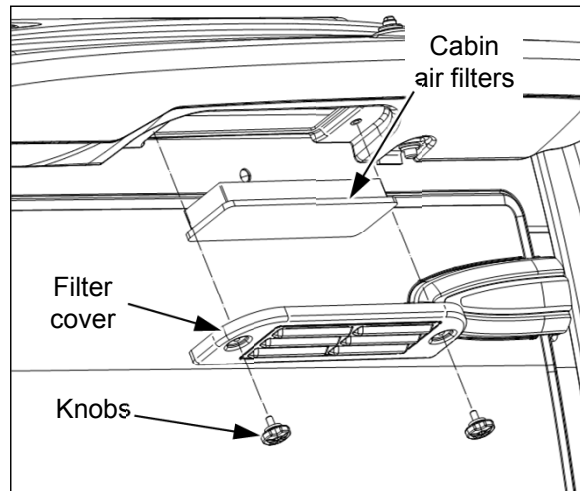

### Notice

- ▶ The filters are made of specially treated media with a rubber sealing strip bonded around the sides. Take care not to damage the element during installation.

## 5-11. Every 1000hr or 1-year check

### (1) Replacing Air cleaner element (Dry type)

- If the air-cleaner service indicator in the instrument panel is turned on, make sure to check and/or replace the filter element regardless of recommended service intervals in this maintenance chart.
- Remove the cover and pull the primary element straight out, ensuring the safety filter element remains in place.
- Clean the inside of the air cleaner housing using a clean damp cloth, being careful not to damage the safety element.
- Check if there is any damage inside the filter element by using a light. If finding a tiny crack or small holes in the filter element or the gasket is damaged, change it with a new one.
- Insert the filter element deeply into the filter housing.
- Remove the dust of the evacuator valve and clean the inside of the cover.
- Assemble the cover with the evacuator valve facing downwards.

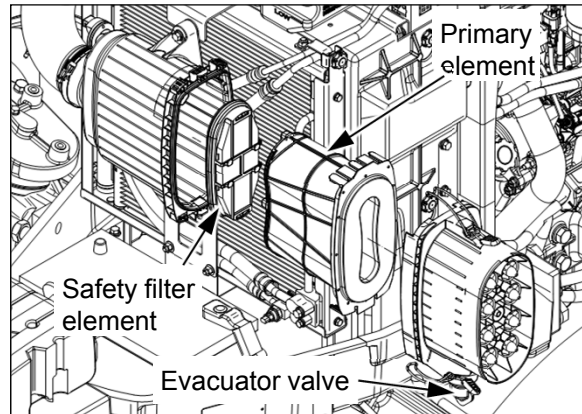



#### Notice

► Do not start the engine or close the hood if the filter element is not assembled..

## (2) Adjusting Engine valve clearance

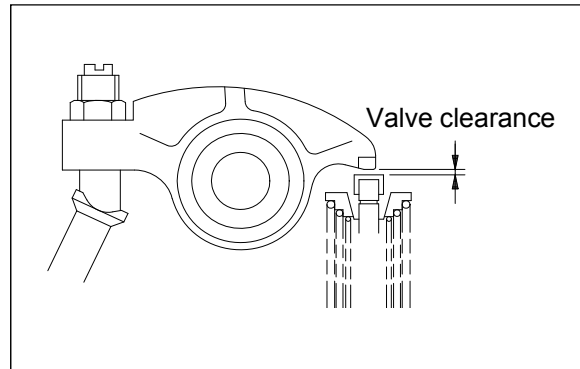
- Contact your authorized dealer to check the valve clearance.  
**Normal: 0.25mm (0.0098 in)**  
 If the gap is large, valves makes a loud tapping noise and if the gap is too small, it is hard to compress by which the engine output falls down or burns a valve.





 <b>Warning</b>	<ul style="list-style-type: none"> <li>▶ Ensure that the engine can not be started while this maintenance is being performed. To help prevent possible injury, do not use the starting motor to turn the flywheel.</li> <li>▶ Hot engine components can cause burns. Allow additional time for the engine to cool before measuring/adjusting valve lash clearance.</li> </ul>
--	---

 <b>Caution</b>	<ul style="list-style-type: none"> <li>▶ Only qualified service personnel should perform this maintenance. Contact your authorized local dealer for this maintenance. Operation of engines with incorrect valve lash can reduce engine efficiency, and also reduce engine component life.</li> </ul>
--	--

## (3) Checking Nozzle injection pressure

- Contact your authorized local dealer for check.  
**Normal injection pressure (Common rail): 180MPa (26100 psi)**

 <b>Warning</b>	<ul style="list-style-type: none"> <li>▶ Fuel leaked or spilled onto hot surfaces or electrical components can cause a fire.</li> <li>▶ Work carefully around an engine that is running. Engine parts that are hot, or parts that are moving, can cause personal injury.</li> <li>▶ Make sure that you wear eye protection at all times during testing. When fuel injection nozzles are tested, the high pressure test fluid can pierce the skin and cause serious injury to the operator. Always keep the tip of the fuel injection nozzle pointed away from the operator and into the fuel collector and extension.</li> </ul>
--	--

 <b>Caution</b>	<ul style="list-style-type: none"> <li>▶ Do not allow dirt to enter the fuel system. Thoroughly clean the area around a fuel system component that will be disconnected. Fit a suitable cover over disconnected fuel system component.</li> <li>▶ If a fuel injector is suspected of operating outside of normal parameters, it should be removed by a qualified technician. The suspect fuel injector should be taken to an authorized agent for inspection.</li> </ul>
--	--

## 5-12. Every 1500hr or 2-year check

### (1) Replacement of Engine coolant

#### ① Check

- Stop the engine and allow the engine to cool down. Loosen the radiator cap slowly in order to relieve any pressure. Remove the radiator cap.
- Check if the coolant of the radiator and reservoir tank is insufficient or not on a daily basis. Check if the coolant level of the reservoir tank is between “Min” and “Max” marks.
- If necessary, add new engine coolant.
- Do not open the radiator cap except to check the coolant or change it.

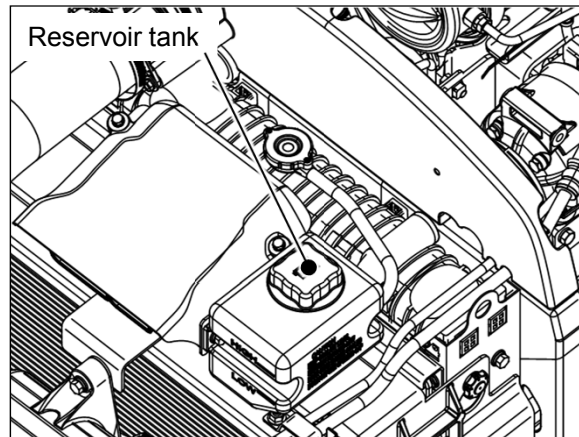
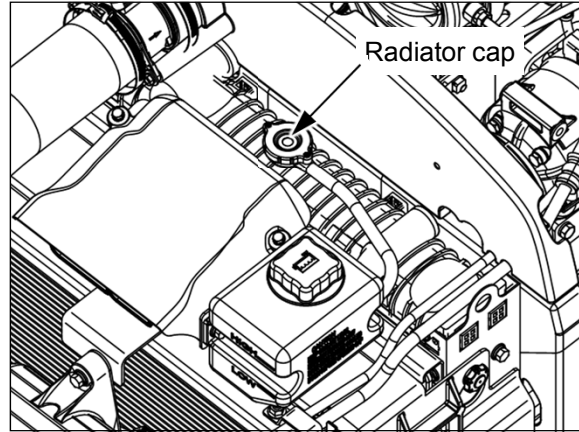

#### ⚠ Warning





- ▶ **Pressurized System:** When opening the radiator cap, be careful of the escaping hot water or steam. Hot coolant can cause serious burns. To open the radiator cap, stop the engine and wait until the cooling system components are cool down. Loosen the radiator cap slowly in order to relieve the pressure.
- ▶ Wear the protection globes or cover the radiator cap with a rag before opening the radiator cap.

#### ② Drain

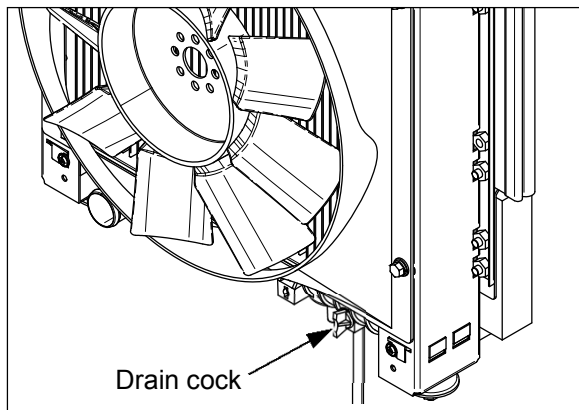
- Stop the engine and allow the engine to cool down. Loosen the radiator cap slowly in order to relieve any pressure. Remove the radiator cap.
- Set a suitable clean container under radiator drain cock and drain plug on the engine.
- Open the drain cock and remove the drain plug on the engine and radiator.
- Allow the coolant to drain completely.

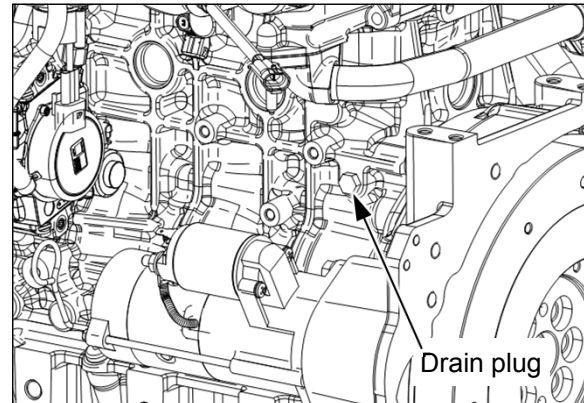
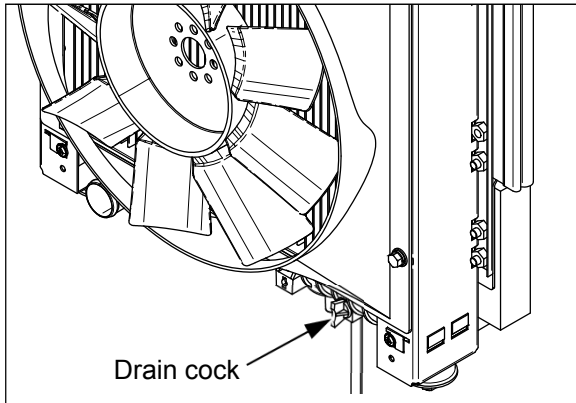



 <b>Caution</b>	<ul style="list-style-type: none"> <li>▶ Care must be taken to ensure that fluids are contained during performance of inspection and maintenance of the product. Be prepared to collect the fluid with suitable containers before opening any compartment or disassembling any component containing fluids.</li> <li>▶ Dispose of all fluids according to Local regulations and mandates.</li> <li>▶ Keep all parts clean from contaminants. Contaminants may cause rapid wear and shortened component life.</li> </ul>
--	---

### ③ Flush

- Flush the cooling system 2~3 times with clean water in order to remove any debris.
- Close the drain cock and install the drain plug on the engine and radiator.
- Fill the cooling system with clean water. Install the radiator cap.
- Start and run the engine at low idle until the temperature reaches 49 to 66 °C (120 to 150 °F).
- Stop the engine and allow the engine to cool. Loosen the radiator cap slowly in order to relieve any pressure. Remove the radiator cap. Open the drain cock or remove the drain plug on the engine and radiator. Allow the water to drain.

 <b>Caution</b>	<ul style="list-style-type: none"> <li>▶ Do not fill the cooling system faster than 5 L (1.3 US gal.) per minute to avoid air locks. Cooling system air locks may result in engine damage.</li> </ul>
--	---

#### ④ Fill

- Close the drain cock and install the drain plug on the engine and radiator.
- Fill the cooling system with the designated coolant. Do not install the radiator cap. *For coolant specification and capacity, see chapter 5-3, "Lubricants and Capacity" or the last page in this manual.*
- Start and run the engine at low idle. Increase the engine rpm to high idle. Run the engine at high idle for one minute in order to purge the air from the cavities of the engine block. Stop the engine.
- Check the coolant level. Maintain the coolant level within 13mm (0.5 in.) below the bottom of the pipe for filling. Maintain the coolant level in the reservoir tank at the correct level.
- Clean the radiator cap. Inspect the gasket that is on the radiator cap. If the gasket is damaged, install a new radiator cap.
- Start the engine. Inspect the cooling system for leaks and for correct operating temperature.
- Use the coolant with anti-freeze solution in cold weather.
- Anti-freeze solution is filled up from the factory. After first winter, change the coolant to remove the debris or corrosion.

 Caution	▶ Do not fill the cooling system faster than 5 L (1.3 US gal.) per minute to avoid air locks. Cooling system air locks may result in engine damage.
---	---

#### ※ Anti-freeze

- The amount of anti-freeze in the coolant must be determined on the ambient temperature. If the amount of anti-freeze in the coolant is low, the coolant can be frozen and the engine and radiator may be damaged.
- Mix the water and anti-freeze with 40%~60% according to operating condition as below table and fill radiator and engine the mixture after checking the volume and capacity.

Anti-freeze (%)	Freezing point °C (°F)	Boiling point °C (°F)	Remark
40	-24 (-11)	106 (223)	
50	-37 (-35)	108 (226)	
60	-52 (-62)	111 (232)	

- If possible, always use the anti-freeze solution. If not, change the coolant with anti-freeze solution before winter time.
- Run the engine for about 5 minutes after filling anti-freeze to mix it with water well.

## (2) Cleaning Emission related parts

- The following items are major engine emission related parts. These items are checked and cleaned periodically. But it is performed by special engine service experts. Contact your authorized local dealer for check.

- EGR Cooler

- Injector Tips

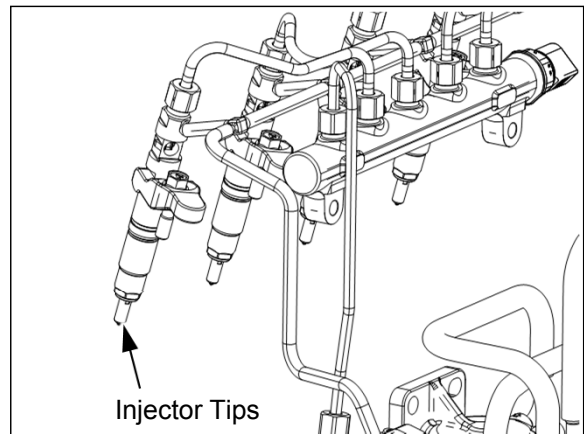
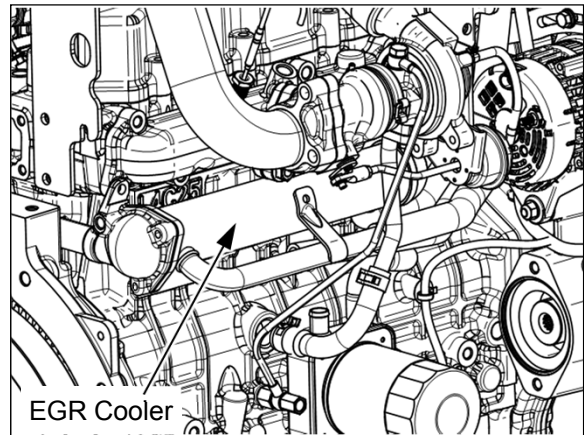

## 5-13. Every 3000hr check

### (1) Cleaning Emission related parts

- The following items are major engine emission related parts. These items are checked and cleaned periodically. But it is performed by special engine service experts. Contact your authorized local dealer for check.

- Fuel injector
- DOC&DPF assembly
- Turbocharger
- ECU
- EGR valve
- Sensors
- Air Control Valve (ACV)

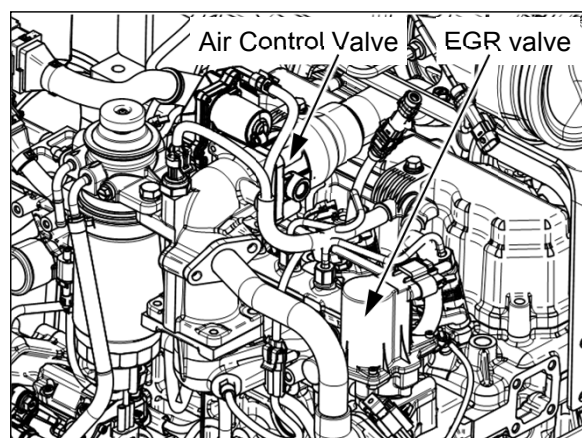
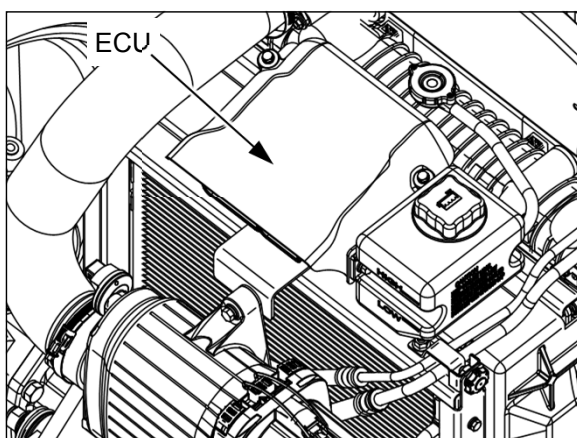
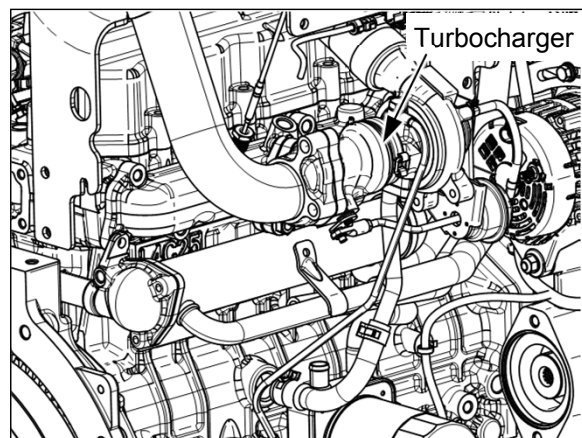
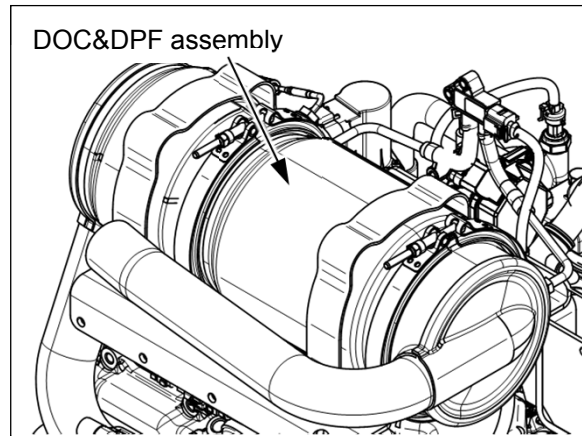





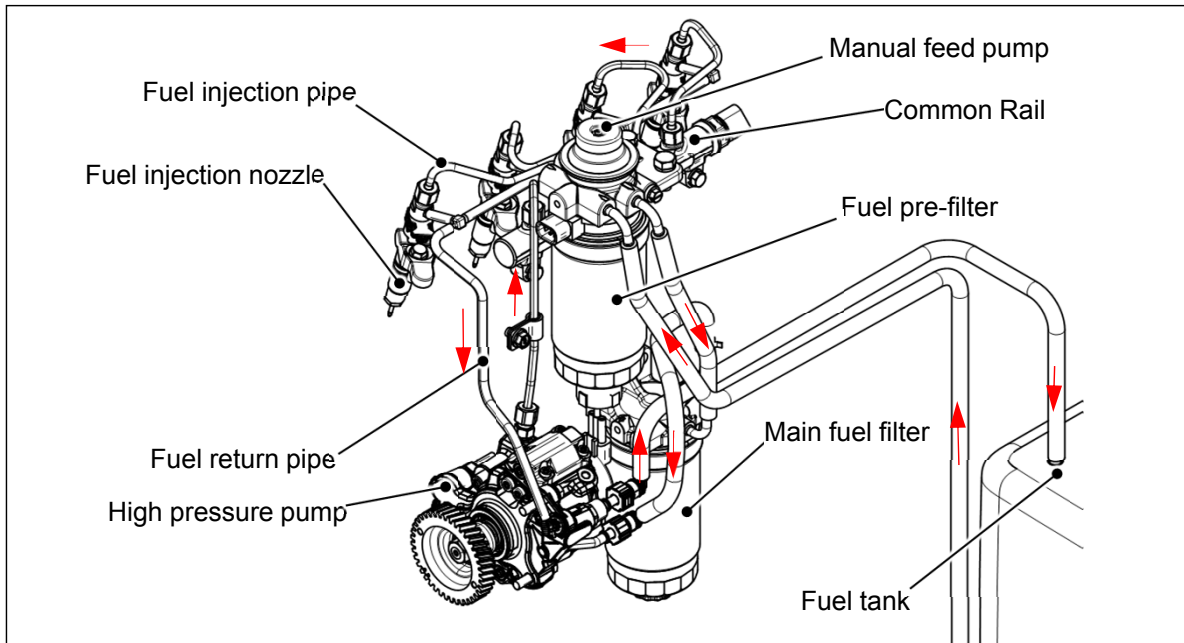

## 5-14. General maintenance (When required)

### (1) Air-bleeding from Fuel system

- Air in the fuel system may cause weak injection or a failure of the engine start or stop. To prevent such a failure, bleed the air from the fuel system.



<p> <b>Danger</b></p>	<p>▶ <b>HIGH PRESSURE FUEL.</b> When the engine is running, do not loosen the fuel injection pipes to bleed air from the fuel system.</p>
<p> <b>Warning</b></p>	<p>▶ Fuel leaked or spilled onto hot surfaces or electrical components can cause a fire. To help prevent possible injury, turn the key switch off when changing fuel filters or water separator elements. Clean up fuel spills immediately.</p>
<p> <b>Caution</b></p>	<p>▶ Do not adjust or modify the fuel injection system arbitrary. It can cause a serious fault related to engine performance and increase of excessive exhaust emissions.</p> <p>▶ Do not allow dirt to enter the fuel system. Thoroughly clean the area around a fuel system component that will be disconnected. Fit a suitable cover disconnected fuel system component. Do not fill the new filter with fuel. Invisible fine contaminants can enter the injection pump and it may cause damage to the fuel injection system.</p>
<p><b>Notice</b></p>	<p>▶ When changing the fuel filter only, it is not necessary to bleed air from the fuel injection pipes.</p>

 <b>Caution</b>	<ul style="list-style-type: none"> <li>▶ Cover the bleeding fuel with a rag so that it does not flow into other components.</li> <li>▶ Do not throw the exhausted waste fuel to any place. This may pollute the soil and water seriously and also is prohibited legally. If violating, you would be responsible for that by civil or criminal case. The waste oil must be disposed according to the environment laws.</li> </ul>
--	--

### ① Air-bleeding from Fuel filter

- After replacing fuel filter, bleed the air in the fuel system.
1. Place a rag or clean container under the air bleed plug and press down the manual feed pump several times.
  2. Unscrew the air bleed plug installed on the fuel filter flange. After bleeding the air bubbles, tighten the air bleed plug slightly.
  3. Repeat the procedure 1 and 2 until there is no more fuel containing air bubbles.
  4. If there is no air bubbles in the flowing fuel, make sure to tighten the air bleed plug firmly.

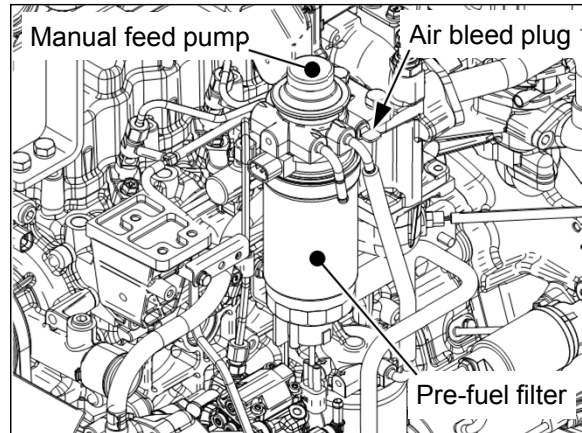

<b>Notice</b>	<ul style="list-style-type: none"> <li>▶ If dust and dirt is stuck to the air bleed plug, it may prevent the air-bleeding. In this case, unscrew the air bleed plug and clean it.</li> </ul>
---------------	--

## ② Air-bleeding from Fuel injection pipe

- DO NOT loosen the high-pressure fuel lines in order to purge air from the fuel system. This procedure is not required.

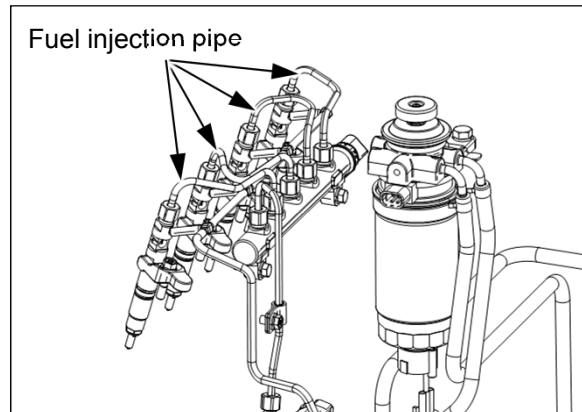

### ► Escaping fluid!

Hydraulic fluid or diesel fuel leaking under pressure can penetrate the skin and cause infection or other injury. To prevent personal injury: Relieve all pressure before disconnecting fluid lines or performing work on the system. Before applying pressure, make sure all connections are tight and all components are in good condition. Never use your hand to check for suspected leaks under pressure. Use a piece of cardboard or wood for this purpose. If injured by leaking fluid, see your doctor immediately.

Failure to comply could result in death or serious injury.

## (2) Air-bleeding from brake lines

1. As the brake system of this tractor is separated into left and right brake, the air bleeding must be carried out separately.
2. Stop engine and apply parking brake. Open the bonnet and fill the brake oil tank with new oil sufficiently. *For oil specification, see page 5-16.*
3. Release the left/right connecting pin of the brake pedals.
4. Loosen the air-bleed plug, and press and hold a brake pedal down slowly up to full stroke.
5. Fasten the plug slightly, and then release the brake pedal. Repeat procedure 4~5 for several times.
6. Check the brake oil level frequently during the air bleeding work.
7. If there is no bubbles coming out through the air bleed plug, check if the brake pedal pressure and equalization is normal. Check the tightening torque of the air-bleed plug.

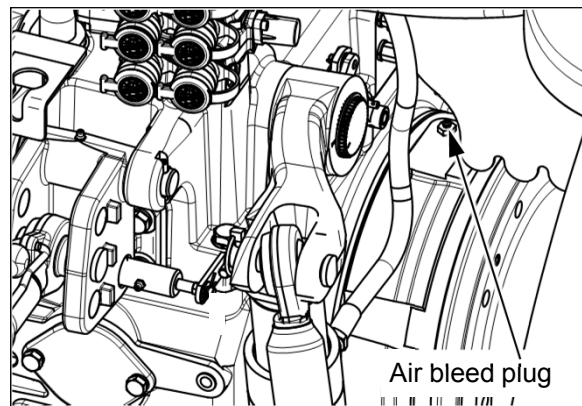
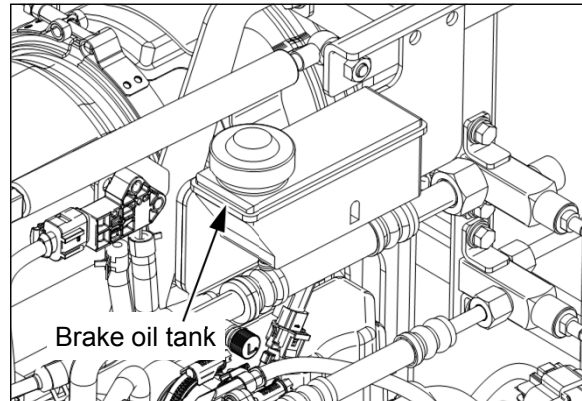

## (3) Air-bleeding from clutch line (Synchro-shuttle models only)

- If there are air bubbles in the hydraulic clutch line, the main clutch may not be released completely.
1. Stop engine and apply parking brake. Fill the brake oil tank with new oil sufficiently. *For oil specification, see page 5-16.*
  2. Carry out air-bleeding work from clutch release cylinder first and clutch master cylinder later.
  3. Loosen the air-bleed plug and press and hold the clutch pedal down slowly up to full stroke.
  4. Fasten the plug slightly and then release the clutch pedal. Repeat procedure 3~4 for several times.
  5. If there is no bubbles coming out through the air bleed plug, check if the main clutch is completely disengaged. Check the tightening torque of the air-bleed plug.

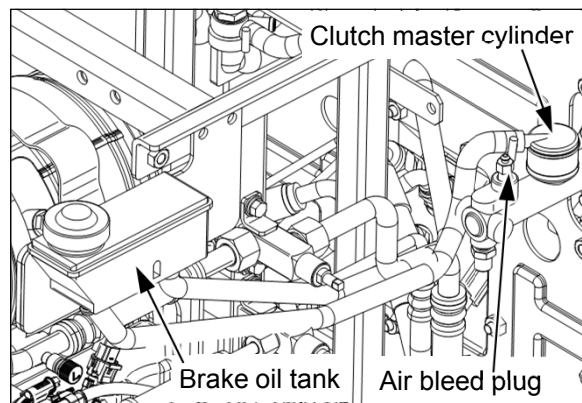
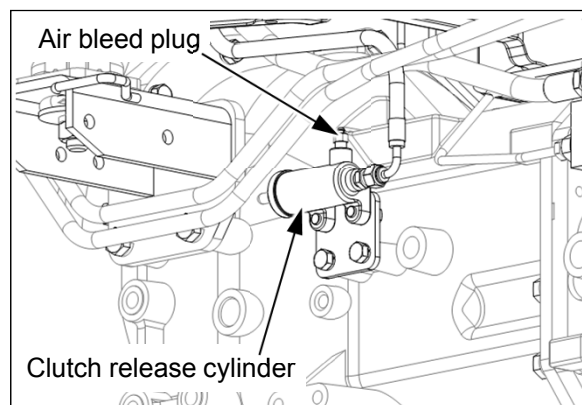

## (4) Fuse & Main fuse

### ① Cabin fuse box

- Cabin fuse box is installed on the right cabin filler.
- How to replace the fuse
  1. Remove the fuse box cover.
  2. Check if each fuse is damaged or not.
  3. Replace it with a new one of the same capacity as the damaged fuse.
- Capacity and function of each fuse is described on the fuse box cover.

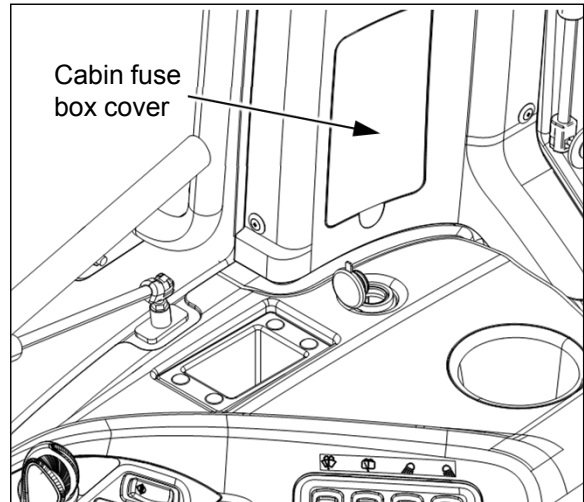

10A	BEACON LAMP	후방작업등 15A REAR WORKING LAMP	에어컨 30A AIR CON.	실내등 외부전원 ROOM LAMP 15A POWER 10A	오디오 10A AUDIO	전방작업등 15A FRONT WORKING LAMP	후방와이퍼/펌프 REAR WIPER / PUMP 10A	전방와이퍼/펌프 FRONT WIPER / PUMP 10A	에어컨 콤프레셔 AIRCON 10A COMPRESSOR
-----	-------------	--------------------------------	---------------------	-------------------------------------	------------------	---------------------------------	--------------------------------	---------------------------------	-----------------------------------

< Cabin fuse box (Cabin type) >

 <b>Caution</b>	<p>▶ If the same function fuse is damaged repeatedly, contact your authorized local dealer for check. Do not use a substitute such as wire or aluminum foil.</p> <p>▶ If using the substitute instead of the rated capacity fuse, it may cause a fire which results in damage of the tractor or serious injury.</p>
--	---

## ② Chassis fuse box

- Chassis fuse box is installed under the front console cover.
- How to replace the fuse
  1. Remove the fuse box cover.
  2. Check if each fuse is damaged or not.
  3. Replace it with a new one of the same capacity as the damaged fuse.

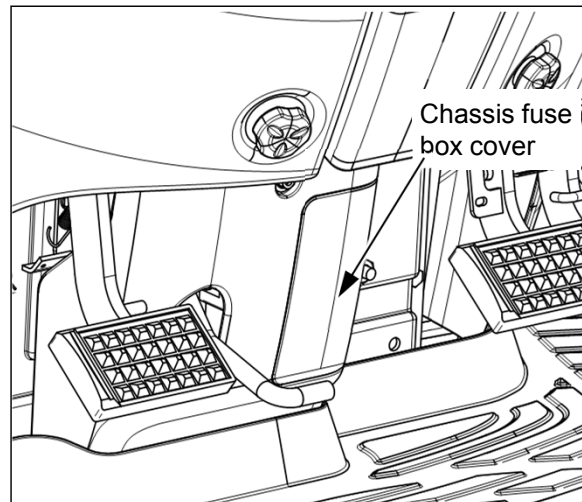

- Capacity and function of each fuse is described on the fuse box cover. Refer to the following page.

Chassis fuse box cover decal

10A SPARE	
15A SPARE	
15A CONTROL SWITCH	10A RELAY
20A AIR SUSPENSION	20A HEAD LAMP
20A SPARE	15A TURN LAMP
10A HAZARD	15A HYD VALVE
10A VEHICLE CONTROLLER(B+)	15A WORK LAMP /HORN
10A CONTROLLER EDPST(B+)	10A VEHICLE CONTROLLER
30A FUEL HEATER	15A CONTROLLER_ED
5A ENGINE CONTROL	15A CONTROLLER_PST
10A ENGINE SENSOR	15A VALVE_PST
40A ECU POWER	15A VALVE_ED

### ③ Main fuse

- Main fuse is attached inside start motor cover in the left side of the engine for protection the electrical circuit and components.
- Disassemble the start motor cover.
- Remove the fuse box cover, If necessary, replace it with a genuine part.

**Rated capacity : 60 A**

- The main fuse is an important part to protect the total electric system of the tractor, if damaged, check if there is a trouble in the electric system. Contact your authorized local dealer for check.

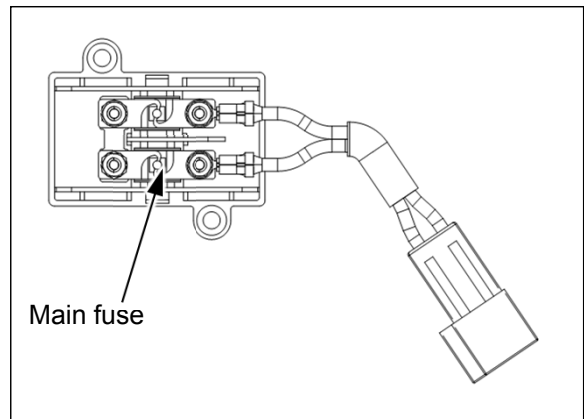
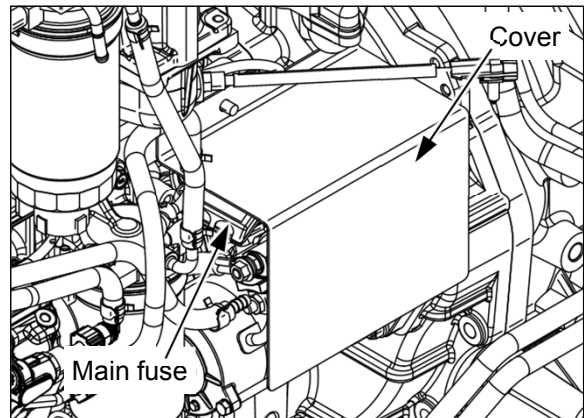

 Caution	<ul style="list-style-type: none"><li>▶ If the main fuse is burn out often, contact your authorized local dealer in order to check the electric system.</li><li>▶ Do not use a substitute instead of the rated genuine fuse. Do not connect electric wire to the battery terminals directly. It may cause a fire and serious injury.</li></ul>
---	--



## (5) Battery handling and Notices

※ **Battery fluid (Electrolyte) is a solution of water and sulfuric acid. It makes poisonous gas which is very harmful to eyes, skin and clothing. And also this gas is explosive. Read the following instructions thoroughly before handling the battery.**

### ① Battery check

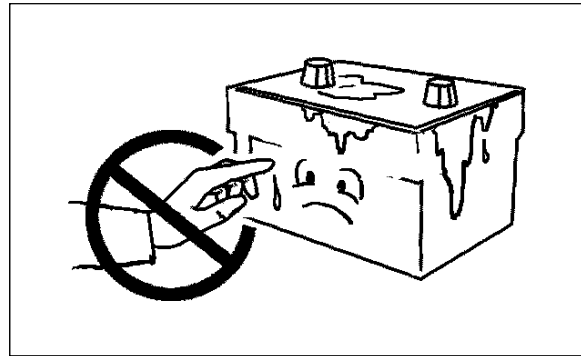
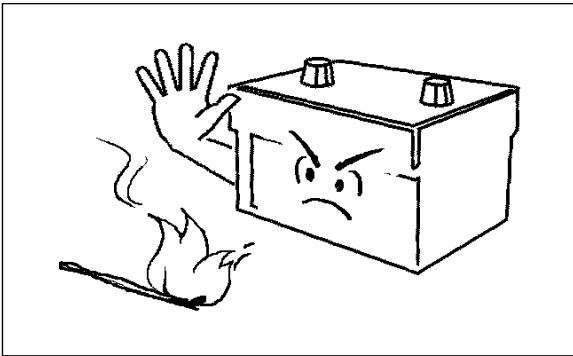
- Indicator(if fitted) on the top of the battery displays the battery state. If the indicator color is
  - **GREEN** : Normal state.  
If the engine does not started despite of green color, contact your authorized dealer.
  - **CLEAN** : Low charging state – charge the battery.
  - **WHITE or RED** : Replace the battery with a new one after checking the vehicle.
- If the terminals of battery harness are loosened, tighten it completely.  
If the terminals of battery are corroded, clean it with warm water apply grease.



<p> <b>Caution</b></p>	<p>▶ The gas generated from the battery is explosive. Comply with the following instructions.</p> <ul style="list-style-type: none"> <li>- Keep cigarettes, sparks and flames away from the battery. Use a flashlight to check battery electrolyte level or indicator.</li> <li>- Never check battery charge by placing a metal object across the terminals. Use a voltmeter or hydrometer.</li> <li>- Always remove grounded (-) battery clamp first and assemble it last. If not, it can cause explosion by spark.</li> </ul>
<p></p>	<p>▶ Sulfuric acid in battery electrolyte is poisonous. It is strong enough to burn skin, clothing and can cause blindness if splashed into the eyes.</p> <ul style="list-style-type: none"> <li>- Never disassemble the battery.</li> <li>- Do not touch the battery or liquid by bare hand without gloves or any protection.</li> <li>- Flush eyes with clean water for about 20 minutes, if the electrolyte is splashed into the eyes, and get medical attention immediately.</li> </ul>
<p></p>	<p>▶ Charge the battery in an area with good ventilation and <b>DO NOT</b> charge a frozen battery.</p> <p>▶ Replace the old battery with a same capacity genuine product.</p>



## ② Notices in attaching/detaching the battery

- When detaching battery, remove the negative(-) terminal from the battery first.  
If not, when metal object is contacted between positive(+) terminal and the body, it may cause the dangerous spark.

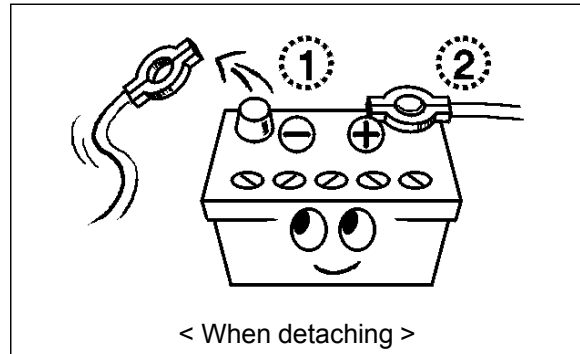

- When attaching the battery, the positive (+) terminal must be attached first and the negative (-) terminal must be connected last.

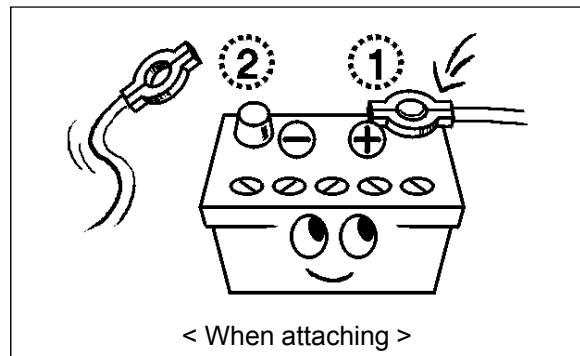

	<p>▶ Stop engine and apply parking brake and remove the ignition key before replacing the battery.</p>
	<p>▶ Put on eye protection and goggles to protect human body from poisonous sulfuric acid before handling the battery.</p>
	<p>▶ Always remove grounded (-) battery clamp first and assemble it last. If not, it can cause an explosion by spark. ▶ Keep all flames and sparks away and DO NOT smoke while charging the battery.</p>
	<p>▶ Replaced old battery must be disposed of in a suitable manner, according to the national legislation or local regulations. Contact your authorized dealer. ▶ Replace the old battery with a same capacity genuine product.</p>

### ③ Notices in charging the battery using separate charger

● As the battery fluid makes poisonous gas which can explode during the charging, comply with the following instructions.

1. Detach battery from the tractor.
2. Wait until the battery is warmed to room temperature.
3. Connect the cable of charger to the (+), (-) terminal of the battery correctly.
  - Connect (+) charger cable to (+) battery terminal. : Red color
  - Connect (-) charger cable to (-) battery terminal. : Black color
4. Plug in charger cord.
5. Charge battery with a "SLOW CHARGE".
6. Check the charging current and temperature of electrolyte during the charging.
7. Unplug charge cord and remove charger cables.
8. Attach battery to the tractor.

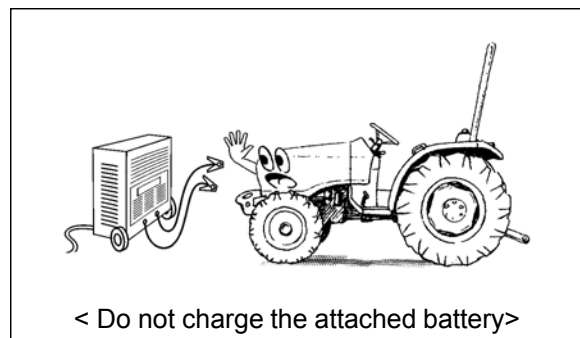
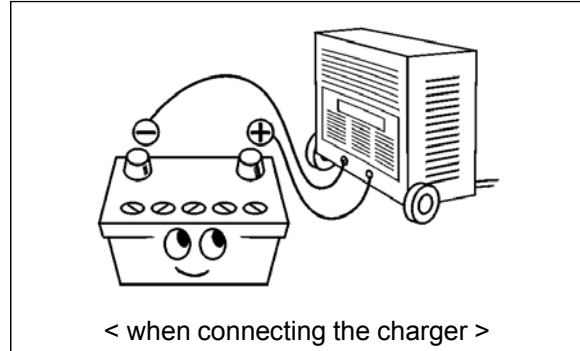

	<p>▶ Put on eye protection and gloves to protect human body from poisonous sulfuric acid before handling the battery .</p>
	<p>▶ Always remove grounded (-) battery clamp first and assemble it last. If not, it can cause explosion by spark.</p> <p>▶ Keep all flames and sparks away and DO NOT smoke while charging the battery.</p>
	<p>▶ Detach battery from the tractor before charging. DO NOT charge directly while the battery is attached to the tractor.</p> <p>▶ Turn off or unplug the charger cord, before connecting or disconnecting the charger cable to or from the battery.</p>
	<p>▶ Charge the battery in an area with good ventilation.</p> <p>▶ Do not charge the frozen battery.</p> <p>▶ Use the rated 12V-5A charger.</p> <p>▶ Never check battery charge by placing a metal object across the terminals.</p>

#### ④ How to use jumper cables



※ If the battery which is attached to the tractor is discharged and needs to connect a auxiliary battery, follow the instructions as below.

##### ① Connecting Jumper cables

- Check followings before connecting the cables.
  - Is the spring of clamp normal?
  - Is the cable and clamp cut-off?

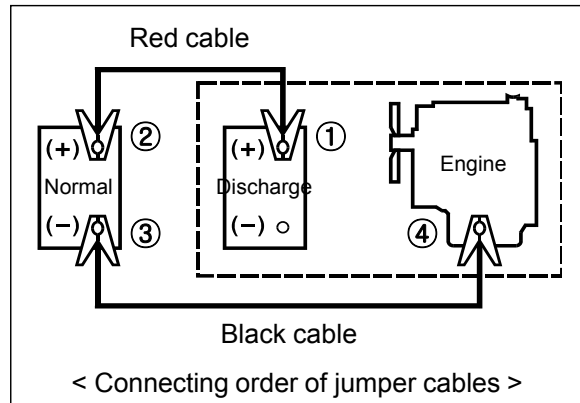
1. Stop engine, apply parking brake and remove the ignition key.
2. Connect two (+) terminals of both batteries with red cable.  
(tractor battery-①, auxiliary battery-②)
3. Connect one end of black cable to (-) terminal(③) of auxiliary battery and the other end to engine block desired to start (④).
4. Start engine. If the engine does not start, check the electrolyte level of each battery.



	<p><b>Caution</b> ▶ The gas generated from the battery can be exploded by spark. DO NOT connect the negative(-) cable of auxiliary battery to the negative (-) terminal of tractor battery. Make sure to connect to the engine block.</p>
	<p>▶ Keep all flames and sparks away and DO NOT smoke while charging the battery.</p>

##### ② Removing Jumper cables

- Remove jumper cables as shown in the right figure, "Removing order of jumper cables".

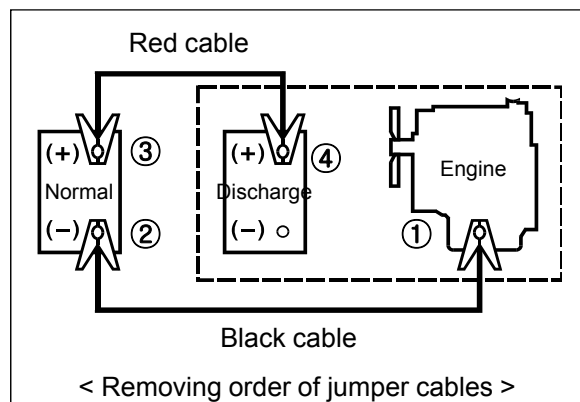

<p><b>Notice</b></p>	<p>▶ Pay attention not to change the (+) and (-) pole. If not, it may cause a failure of electric circuit or the damage of wire and even the polarity of battery can be changed at over-discharged state.</p>
----------------------	---

## (6) Alternator and drive belt - Check

- The tractor alternator① is belt-driven from the engine crankshaft pulley. It is important that belt slippage does not occur, or the charging system will be affected.

*To adjust the fan belt, see page 5-34.*

- Required alternator periodical maintenance:

- Belt adjustment
- Inspect alternator terminals
- Clean alternator cooling fan fins

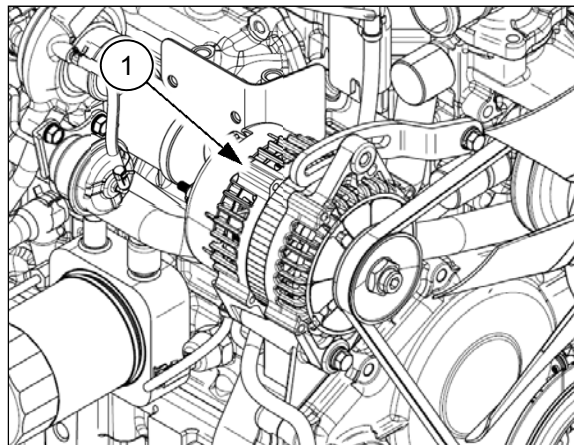

- When working on or checking the alternator, adhere to following precautions. If not, alternator damage may occur:
  - Do not UNDER ANY CIRCUMSTANCES short the field terminal of the alternator to ground.
  - Do not disconnect the alternator output lead or battery cables while the alternator is operating.
  - Do not remove the alternator from the tractor without first disconnecting the negative (-) battery cable. When removing the battery, disconnect the negative (-) cable first.
  - To install a battery, MAKE SURE that the positive (+) cable is connected first and that the negative terminal is connected to ground. Reverse polarity will destroy the rectifier diodes in the alternator.

**NOTE:** *If the battery charge warning indicator illuminates, indicating that the alternator is not charging the battery, check the fan belt and the wiring connections. If these items are in satisfactory condition and the warning light continues to indicate no charge, contact your authorized local dealer.*

## (7) Turn signal light bulb- Replace

### ① Rear turn signal light bulb - replacement

1. Remove the rubber grommet from the socket. Carefully access the socket not to get hurt by mug guard bracket.
2. Turn the socket counter-clockwise and remove the socket from the housing.
3. Push in on the turn signal light bulb and rotate counter-clockwise in the socket to remove the old bulb.
4. Insert the new bulb into the socket and turn the bulb in a clockwise direction until tightened.
5. Install the socket and rubber grommet.

**NOTE:** For about bulb specification, refer to the chapter 5-6-(4) in this manual.

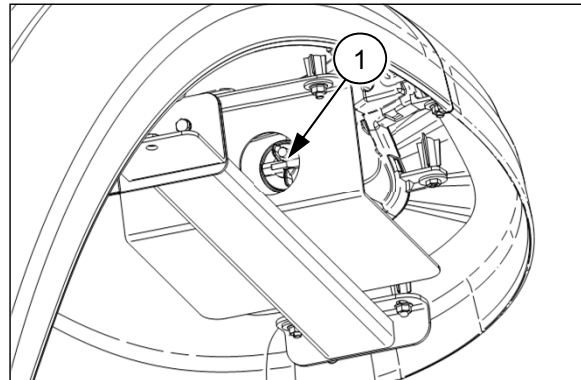

### ② Front turn signal light bulb - replacement

1. Remove the three screws① retaining the turn signal light assembly and remove the assembly.
2. Turn the socket counter-clockwise and remove the socket from the housing.
3. Push in on the turn signal light bulb and rotate counterclockwise in the socket to remove the old bulb.
4. Insert the new bulb into the socket and turn the bulb in a clockwise direction until tightened.
5. Install the socket to the housing.
6. Install the turn signal light assembly to the cover and tighten the retaining screws.

**NOTE:** For about bulb specification, refer to the chapter 5-6-(4) in this manual.

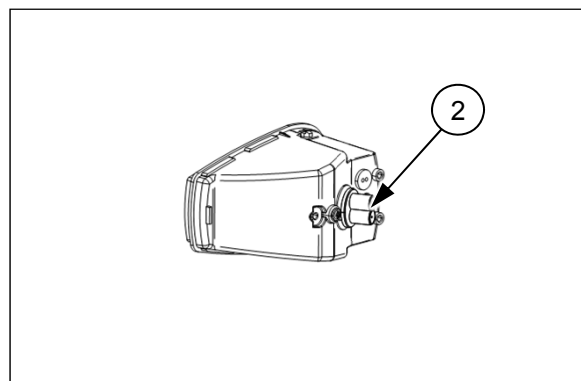
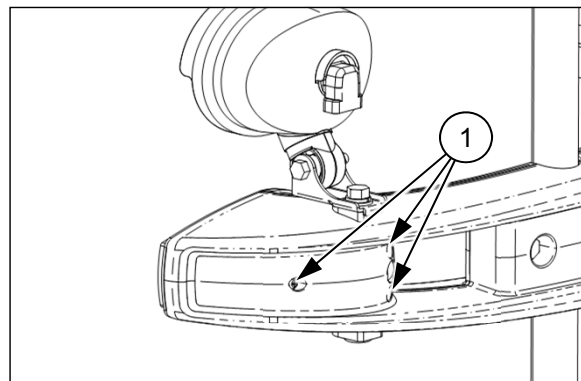

## (8) Headlight bulb - Replace

### ① Headlight bulb

- If a headlight bulb ① fails to operate, the bulb must be replaced as below.

1. Open the tractor hood.
2. Remove the rubber grommet and harness connector.
3. Unlatch the locking spring on the bulb and remove the headlight bulb from the housing.
4. Insert a new bulb into the housing and install the locking spring on the bulb to secure.
5. Reinstall the harness connector and rubber grommet.

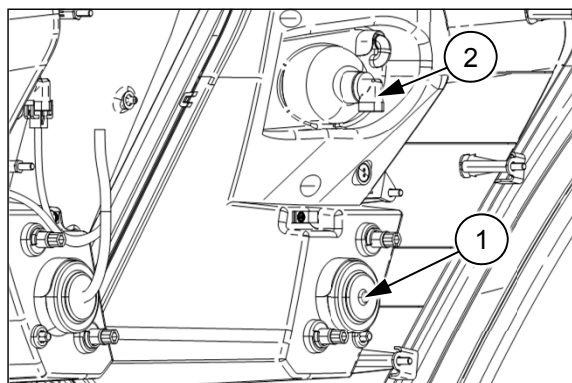

**NOTE:** For about bulb specification, refer to the chapter 5-6-(4) in this manual.

 Caution	<p>▶ Be careful not to touch the bulb with bare fingers. Oil from the fingers can shorten the life of bulb. Use protective cloth or glove when installing bulb.</p> <p>▶ Bulb and surroundings are very hot while working. Be careful not to touch the bulb with bare fingers. It may cause a burn of your hand. Before servicing the bulb, turn off the light and cool down the bulb.</p>
---	--

### ② Grille work light bulb

- If a grille work light bulb ② fails to operate, the bulb must be replaced as below.

1. Open the tractor hood.
2. Remove the harness connector.
3. Turn the damaged bulb 1/4 turn counter-clockwise and remove bulb from holder.
4. Insert a new bulb into the holder and turn 1/4 turn clockwise to secure.
5. Reinstall the harness connector.

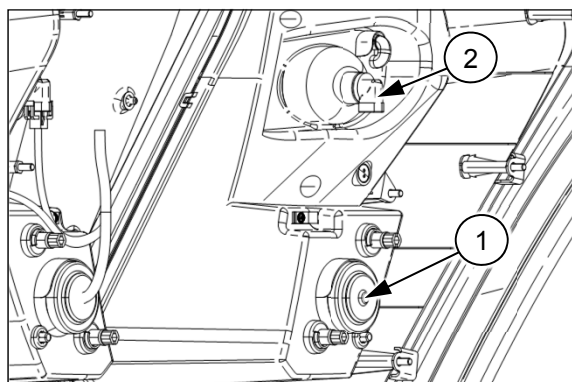

**NOTE:** For about bulb specification, refer to the chapter 5-6-(4) in this manual.

## (9) Touch-up paint color

- The following color specifications are recommended for touch-up paint repairs.
- You must use acryl urethane paint.

<b>Color</b>	<b>Parts</b>	<b>Munsell number</b>
Sky Blue	Hood, Fenders	10B 4/10
Dark Gray N2	Remote control lever guide	N2
Dark Gray N3	Left/Right-hand interior trims	N3
LS Cool Gray	Instrument covers, Console cover	10B 4/1
White Ivory	Wheels	5Y 8.5/2
Black	Transmission case, Front axle	N1.0

## 5-15. Troubleshooting

 <b>Warning</b>	▶ To avoid injury due to sudden start, apply parking brake and place the transmission gear in NEUTRAL position before checking and repairing.
--	---

System	Faults	Possible causes	Solutions
Engine	The start motor does not turn when turning the key switch.	<ul style="list-style-type: none"> <li>▲ Start safety switch is not contacted</li> <li>▲ PTO switch is not on "OFF" position</li> <li>▲ Discharge of battery</li> <li>▲ Terminal loosened</li> <li>▲ Key switch failure</li> <li>▲ Start motor failure</li> </ul>	<ul style="list-style-type: none"> <li>▲ Depress the clutch pedal fully</li> <li>▲ Place PTO switch on "OFF" position</li> <li>▲ Charge or replace</li> <li>▲ Tighten</li> <li>▲ Repair or replace</li> <li>▲ Repair or replace</li> </ul>
	The start motor turns but the engine does not start.	<ul style="list-style-type: none"> <li>▲ The battery is weak</li> <li>▲ bad ground</li> <li>▲ Improper viscosity of engine oil</li> <li>▲ Air in fuel system</li> <li>▲ Fuel filter clogged</li> <li>▲ Error in engine body</li> <li>▲ Fuel cock closed</li> </ul>	<ul style="list-style-type: none"> <li>▲ Charge or replace</li> <li>▲ Tighten the ground</li> <li>▲ Replace the oil with proper viscosity</li> <li>▲ Bleed the air</li> <li>▲ Wash or replace the filter</li> <li>▲ Repair</li> <li>▲ Open the cock</li> </ul>
	Engine revolution is irregular.	<ul style="list-style-type: none"> <li>▲ Air in fuel system</li> <li>▲ Fuel filter clogged</li> <li>▲ Injection nozzle clogged</li> <li>▲ Fuel leakage</li> <li>▲ Irregular fuel injection</li> </ul>	<ul style="list-style-type: none"> <li>▲ Bleed air</li> <li>▲ Clean or replace the filter</li> <li>▲ Repair or replace</li> <li>▲ Repair</li> <li>▲ Repair</li> </ul>
	Engine turns more than maximum speed.	<ul style="list-style-type: none"> <li>▲ Impurities in governor</li> </ul>	<ul style="list-style-type: none"> <li>▲ Repair</li> </ul>
	Engine stops suddenly during operation.	<ul style="list-style-type: none"> <li>▲ Fuel shortage</li> <li>▲ Fault of nozzle</li> <li>▲ moving parts failure due to bad lubrication</li> </ul>	<ul style="list-style-type: none"> <li>▲ Add fuel and bleed air</li> <li>▲ Repair or replace</li> <li>▲ Repair</li> </ul>
	Engine stops at low rpm.	<ul style="list-style-type: none"> <li>▲ Fault of High pressure pump</li> <li>▲ Valve gap is not correct</li> <li>▲ Poor nozzle pressure</li> </ul>	<ul style="list-style-type: none"> <li>▲ Repair</li> <li>▲ Adjust the gap</li> <li>▲ Repair</li> </ul>



<b>System</b>	<b>Faults</b>	<b>Possible causes</b>	<b>Solutions</b>
Engine	Engine overheat	<ul style="list-style-type: none"> <li>▲ Lack of engine coolant</li> <li>▲ Bad fan belt tension or broken</li> <li>▲ Dirt attached to the radiator</li> </ul>	<ul style="list-style-type: none"> <li>▲ Supplement</li> <li>▲ Adjust belt tension or replace</li> <li>▲ Clean</li> </ul>
	The color of exhausted smoke is white.	<ul style="list-style-type: none"> <li>▲ Air cleaner clogged</li> <li>▲ Engine oil exceeded</li> <li>▲ Lack of fuel supply</li> </ul>	<ul style="list-style-type: none"> <li>▲ Wash element</li> <li>▲ Adjust in proper level</li> <li>▲ Repair</li> </ul>
	The color of exhausted smoke is black.	<ul style="list-style-type: none"> <li>▲ Bad quality of fuel</li> <li>▲ Oversupply of fuel</li> <li>▲ Fault of nozzle</li> </ul>	<ul style="list-style-type: none"> <li>▲ Use good quality fuel</li> <li>▲ Repair</li> <li>▲ Repair</li> </ul>
	Engine power is low.	<ul style="list-style-type: none"> <li>▲ Injection nozzle clogged</li> <li>▲ Carbon piled to valve seat</li> <li>▲ Bad adjustment of valve gap</li> <li>▲ Bad injection timing</li> <li>▲ Lack of fuel supply</li> <li>▲ Air cleaner clogged</li> </ul>	<ul style="list-style-type: none"> <li>▲ Repair</li> <li>▲ Repair</li> <li>▲ Repair</li> <li>▲ Repair</li> <li>▲ Check fuel system</li> <li>▲ Clean or replace</li> </ul>
	Engine oil pressure indicator is ON during operation.	<ul style="list-style-type: none"> <li>▲ Lack of engine oil</li> <li>▲ Low viscosity of engine oil</li> <li>▲ Warning light switch error</li> <li>▲ Fault of oil pump</li> <li>▲ Oil filter element is clogged</li> </ul>	<ul style="list-style-type: none"> <li>▲ Supplement</li> <li>▲ Replace the proper oil viscosity</li> <li>▲ Replace</li> <li>▲ Repair</li> <li>▲ Replace element</li> </ul>
	Battery charging indicator is ON during operation	<ul style="list-style-type: none"> <li>▲ Abnormal wiring</li> <li>▲ Fault of alternator</li> <li>▲ Fault of battery</li> <li>▲ Bad fan belt tension or broken</li> </ul>	<ul style="list-style-type: none"> <li>▲ Check battery terminals and ground, repair</li> <li>▲ Repair or replace</li> <li>▲ Replace</li> <li>▲ Adjust belt tension or replace</li> </ul>
	Electronic control errors related with TIER4 engine.	<ul style="list-style-type: none"> <li>▲ Fault of electric sensors or wire harness or ECU</li> </ul>	<ul style="list-style-type: none"> <li>▲ Contact your authorized local dealer.</li> </ul>
Clutch	Clutch is slipped.	<ul style="list-style-type: none"> <li>▲ Wrong clutch pedal play</li> <li>▲ Friction lining worn or broken</li> </ul>	<ul style="list-style-type: none"> <li>▲ Adjust</li> <li>▲ Replace</li> </ul>
	Clutch does not cut-off.	<ul style="list-style-type: none"> <li>▲ Lining damaged</li> <li>▲ Wrong clutch pedal play</li> </ul>	<ul style="list-style-type: none"> <li>▲ Repair or replace</li> <li>▲ Adjust</li> </ul>

<b>System</b>	<b>Faults</b>	<b>Possible causes</b>	<b>Solutions</b>
Brake	Brake does not work or only one side works.	<ul style="list-style-type: none"> <li>▲ Wrong brake pedal play</li> <li>▲ Lining worn or broken</li> <li>▲ Left/right pedal play is different</li> <li>▲ Air in brake line</li> </ul>	<ul style="list-style-type: none"> <li>▲ Adjust</li> <li>▲ Replace</li> <li>▲ Adjust</li> <li>▲ Bleed air</li> </ul>
	After brake pedal working, it does not return.	<ul style="list-style-type: none"> <li>▲ Return spring damaged</li> <li>▲ Lack of grease in shaft parts</li> <li>▲ Master cylinder seal damaged</li> </ul>	<ul style="list-style-type: none"> <li>▲ Replace the spring</li> <li>▲ Remove the rust, apply grease</li> <li>▲ Replace</li> </ul>
Hydraulic lift system	The linkage does not move up.	<ul style="list-style-type: none"> <li>▲ Lack of transmission oil</li> <li>▲ Air in the suction pipe</li> <li>▲ Hydraulic filter clogged</li> <li>▲ Hydraulic pump failure</li> <li>▲ Control valve failure</li> <li>▲ Cylinder or cylinder related parts broken</li> </ul>	<ul style="list-style-type: none"> <li>▲ Add oil</li> <li>▲ Tighten the filter or replace seal of connecting part</li> <li>▲ Clean the filter or replace</li> <li>▲ Repair or replace</li> <li>▲ Repair or replace</li> <li>▲ Repair or replace</li> </ul>
	Oil leakage	<ul style="list-style-type: none"> <li>▲ Connecting part loosened</li> <li>▲ Oil seal damaged</li> <li>▲ Pipe cracked</li> </ul>	<ul style="list-style-type: none"> <li>▲ Tighten</li> <li>▲ Replace</li> <li>▲ Replace</li> </ul>
	If lever is placed on the raising position, relief valve sounds off.	<ul style="list-style-type: none"> <li>▲ Upper limit of position control lever is changed</li> </ul>	<ul style="list-style-type: none"> <li>▲ Adjust the upper limit</li> </ul>
	The linkage does not move down.	<ul style="list-style-type: none"> <li>▲ Down speed control valve locked</li> <li>▲ Control valve failure</li> <li>▲ Cylinder damaged</li> <li>▲ Lift shaft moving part damaged</li> </ul>	<ul style="list-style-type: none"> <li>▲ Turn the knob counter-clockwise</li> <li>▲ Repair or replace</li> <li>▲ Replace</li> <li>▲ Repair or replace</li> </ul>

System	Faults	Possible causes	Solutions
Steering System	Hydraulic steering system does not work.	<ul style="list-style-type: none"> <li>▲ Pump worn or part damaged</li> <li>▲ Steering unit damaged or worn</li> <li>▲ Oil leakage by steering cylinder piston seal damaged or worn</li> <li>▲ Oil leakage by pipe damage</li> </ul>	<ul style="list-style-type: none"> <li>▲ Repair or replace</li> <li>▲ Repair or replace</li> <li>▲ Repair</li> <li>▲ Repair or replace</li> </ul>
	Hard to operate the steering wheel.	<ul style="list-style-type: none"> <li>▲ Steering unit <ul style="list-style-type: none"> <li>- Steering unit spline and column spline is not aligned</li> <li>- Spool and sleeve damaged by foreign material</li> <li>- Excessive tightening torque of end cap bolt</li> </ul> </li> <li>▲ Pump <ul style="list-style-type: none"> <li>- Low speed</li> <li>- Wearing or failure</li> </ul> </li> <li>▲ Relief valve <ul style="list-style-type: none"> <li>- Valve spool clogged</li> <li>- Setting pressure too low</li> </ul> </li> </ul>	<ul style="list-style-type: none"> <li>▲ <ul style="list-style-type: none"> <li>- Check mounted condition of steering unit and column</li> <li>- Replace</li> <li>- Apply regular torque</li> </ul> </li> <li>▲ <ul style="list-style-type: none"> <li>- Adjust RPM or Repair</li> <li>- Repair or replace</li> </ul> </li> <li>▲ <ul style="list-style-type: none"> <li>- Repair or replace</li> <li>- Reset or adjust</li> </ul> </li> </ul>
	Cylinder does not work smoothly as steering wheel movement	<ul style="list-style-type: none"> <li>▲ Air in steering line if not used for a long time</li> <li>▲ Air in suction pipe</li> <li>▲ Piston seal damaged</li> </ul>	<ul style="list-style-type: none"> <li>▲ Bleed air</li> <li>▲ Repair</li> <li>▲ Replace</li> </ul>
	Steering wheel turns to the opposite direction.	<ul style="list-style-type: none"> <li>▲ bad assembly of steering gear</li> <li>▲ bad assembly of steering hose</li> </ul>	<ul style="list-style-type: none"> <li>▲ Repair</li> <li>▲ Repair</li> </ul>
	Oil leakage of steering pump, steering unit, cylinder and fittings	<ul style="list-style-type: none"> <li>▲ Seal damaged</li> </ul>	<ul style="list-style-type: none"> <li>▲ Replace seal</li> </ul>
	Abnormal noise	<ul style="list-style-type: none"> <li>▲ Lack of oil</li> <li>▲ Exceeding resistance of suction line</li> <li>▲ Air in system</li> </ul>	<ul style="list-style-type: none"> <li>▲ Aid oil</li> <li>▲ Replace filter or repair pump</li> <li>▲ Bleed air</li> </ul>

<b>System</b>	<b>Faults</b>	<b>Possible causes</b>	<b>Solutions</b>
Electric System	Battery is not charge	<ul style="list-style-type: none"> <li>▲ Abnormal wiring</li> <li>▲ Alternator failure</li> <li>▲ Lack of fan belt tension or broken</li> <li>▲ Abnormal battery</li> </ul>	<ul style="list-style-type: none"> <li>▲ Check the tightening state of terminal and ground</li> <li>▲ Repair or replace</li> <li>▲ Adjust fan belt tension or replace</li> <li>▲ Replace</li> </ul>
	Headlight is dark.	<ul style="list-style-type: none"> <li>▲ Battery capacity is low</li> <li>▲ Bad wiring and contact</li> </ul>	<ul style="list-style-type: none"> <li>▲ Charge or replace</li> <li>▲ Check and repair</li> </ul>
	Headlight does not ON.	<ul style="list-style-type: none"> <li>▲ Light bulb cut-off</li> <li>▲ Fuse blown</li> </ul>	<ul style="list-style-type: none"> <li>▲ Replace</li> <li>▲ Check the cause, and replace</li> </ul>
	Horn does not sound.	<ul style="list-style-type: none"> <li>▲ Switch failure</li> <li>▲ Abnormal wiring</li> <li>▲ Horn failure</li> </ul>	<ul style="list-style-type: none"> <li>▲ Replace</li> <li>▲ Repair</li> <li>▲ Replace</li> </ul>
	Turn signal Light does not work.	<ul style="list-style-type: none"> <li>▲ Light bulb cut-off</li> <li>▲ Bad connection</li> <li>▲ Fuse blown</li> </ul>	<ul style="list-style-type: none"> <li>▲ Replace</li> <li>▲ Tighten terminals</li> <li>▲ Check the cause, and replace it</li> </ul>
	Cold start aid indicator does not ON. (option)	<ul style="list-style-type: none"> <li>▲ Relay or timer damaged</li> <li>▲ Bad connection of preheat plug wiring</li> </ul>	<ul style="list-style-type: none"> <li>▲ Replace</li> <li>▲ Check and tighten</li> </ul>
	Other illuminating and indicator does not ON.	<ul style="list-style-type: none"> <li>▲ Fuse blown</li> <li>▲ Light bulb cut-off</li> </ul>	<ul style="list-style-type: none"> <li>▲ After removing the cause, and replace</li> <li>▲ Replace</li> </ul>

# 6. Air Conditioning System (Cabin type)

## 6-1. The name of each part of cooling and heating system

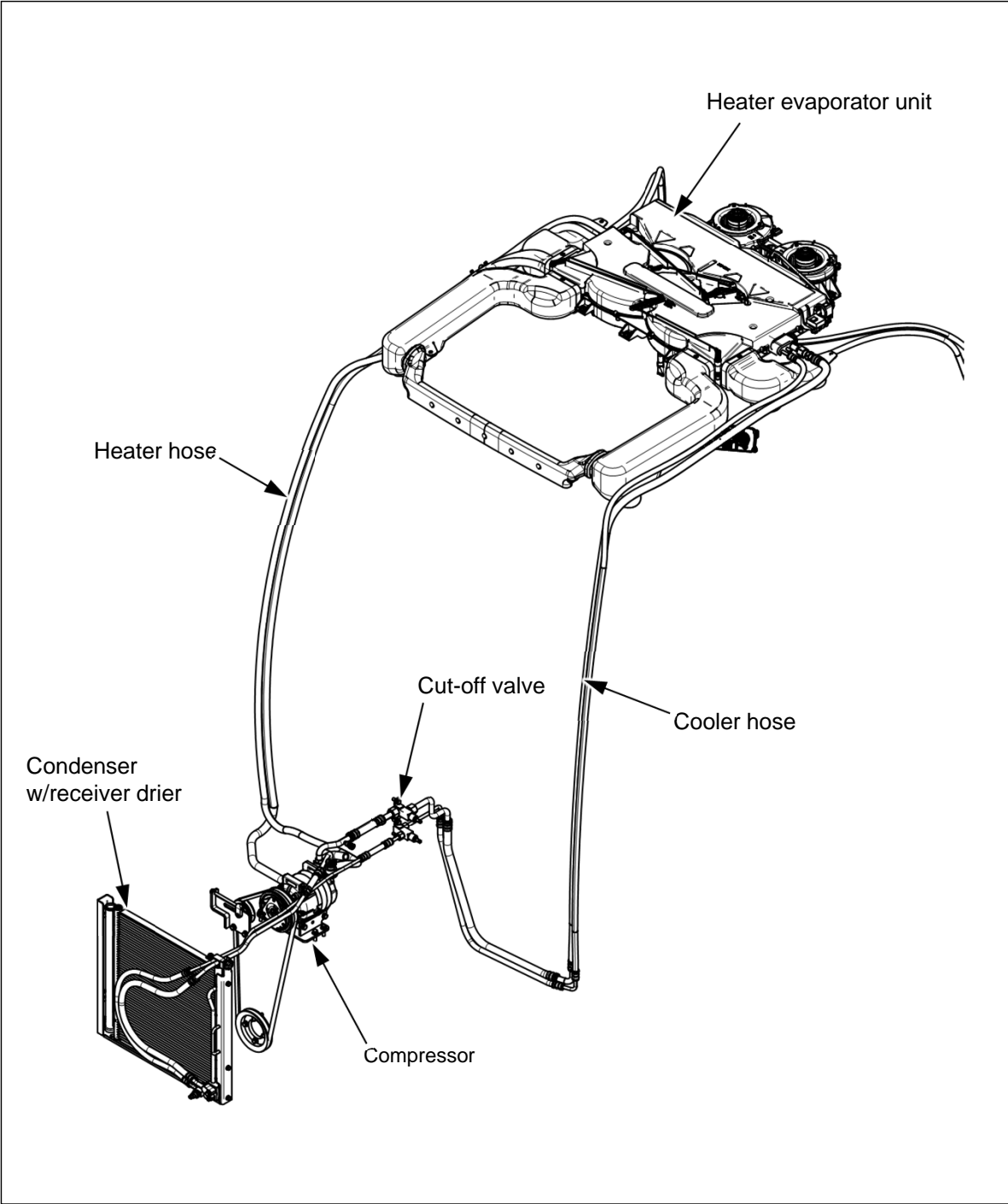

 Caution	<p>► Maintenance of the air conditioning system and components (Compressor, Receiver drier, Condenser, Heater evaporator unit and connection parts) must be performed in a designated dealer. DO NOT disassemble the components arbitrary.</p>
---	--

## 6-2. How to use Air conditioner and Heater

### (1) How to operate air conditioner and heater

- Air-conditioner switch and Blower control switch
  - It is used to operate the air conditioner. If you push the air-conditioner switch and turn the blower control switch to 1~4 position, the operation lamp shall be ON and the air conditioner begins to work.
- Direction control switch
  - It is used to select the air flow direction – front grille, front & side grille, side grille.
- Heater control switch
  - It is used for selecting warm or cool air. Turn the switch clockwise (blue mark) for cool air, and otherwise, turn it counter-clockwise (red mark).

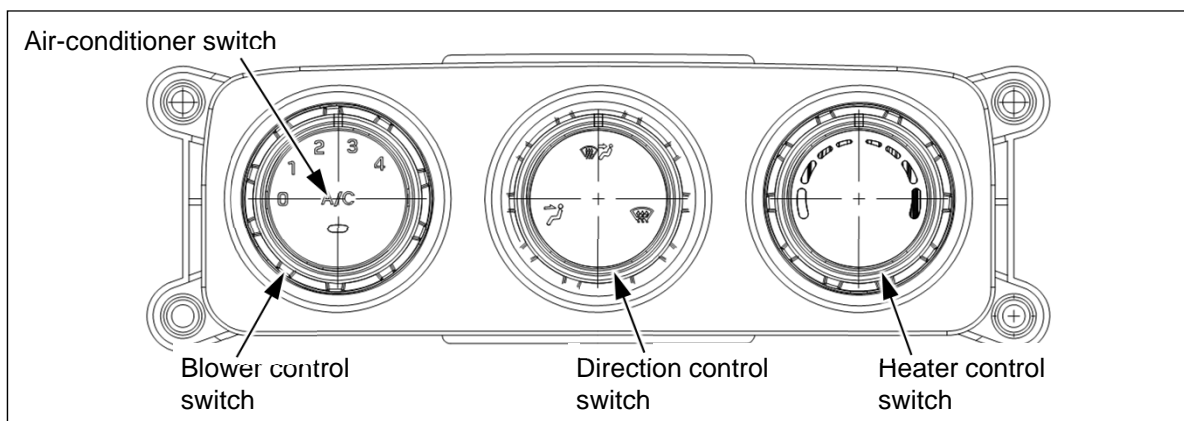

### (2) Air direction control

- To control the air flow direction, adjust the blade angle of the blower outlets.
- For internal circulation, move the ventilation lever to the internal circulation position.
- When operating the air conditioner or heater, open the blower outlets always.

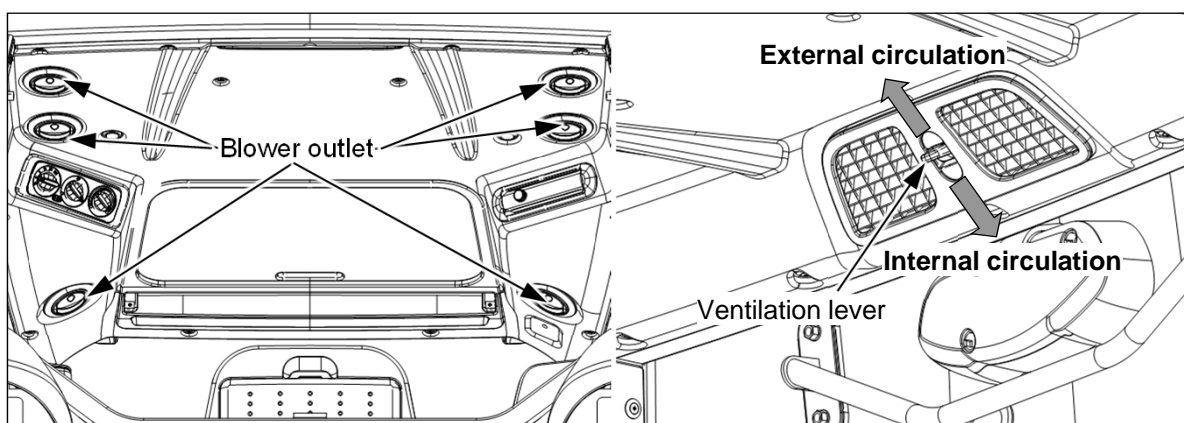

 <b>Caution</b>	<ul style="list-style-type: none"><li>▶ Never sleep in the cabin with the air conditioner or heater turned on. It may cause suffocation.</li><li>▶ When operating in the cabin for a long time, ventilate the cabin frequently.</li></ul>
--	---

## 6-3. Every 6 month check

### (1) Checking refrigerant amount

- Check the refrigerant amount periodically. Contact your authorized dealer for it. The components of the air conditioning system have to be handled by authorized service experts.
- Refrigerant and capacity: R-134a, 750g (26.5 oz)

### (2) Cleaning Condenser and Radiator screen

- Stop engine and allow the engine to cool. Open bonnet.
- Unscrew the knob and pull out the condenser to the left-hand side.
- Remove dust and dirt, dry grass, and other debris stuck to the condenser, fuel cooler (if fitted), TM oil cooler (if fitted), radiator and radiator screen with soft brush or low pressurized air or water.
- Pay attention that the cooling fins are not damaged. If necessary, repair the deformed fins.
- Depending on the working conditions, shorten the service interval reasonably.

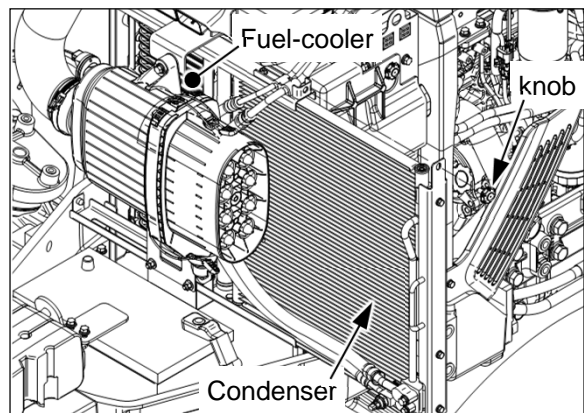
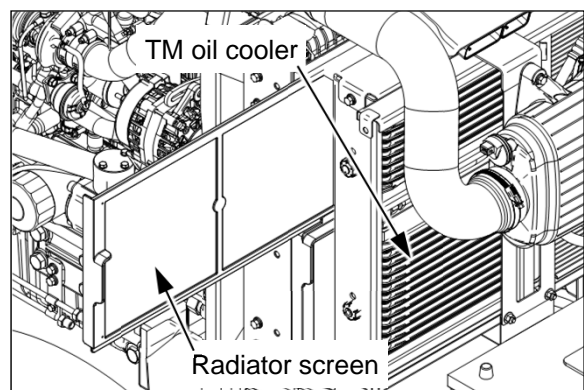

### (3) Checking Leakage

- Check the tightening torque and oil leakage of the connecting parts.
- Oil spots or stains on the connecting parts indicate the possibility of refrigerant leak. Check the refrigerant amount.

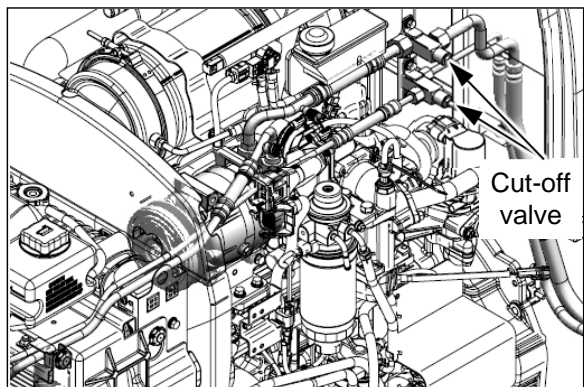

#### (4) Belt tension adjustment

- Check if the belt tension is suitable and if necessary, adjust the belt tension with the tension adjust bolt.
- **Tension : approx. 10~12 mm (0.4~0.5 in.) (when pressed by 50N (11 lb))**
- Check the damaged part of the belt and if necessary, replace it with a new one after checking the pulley alignment.

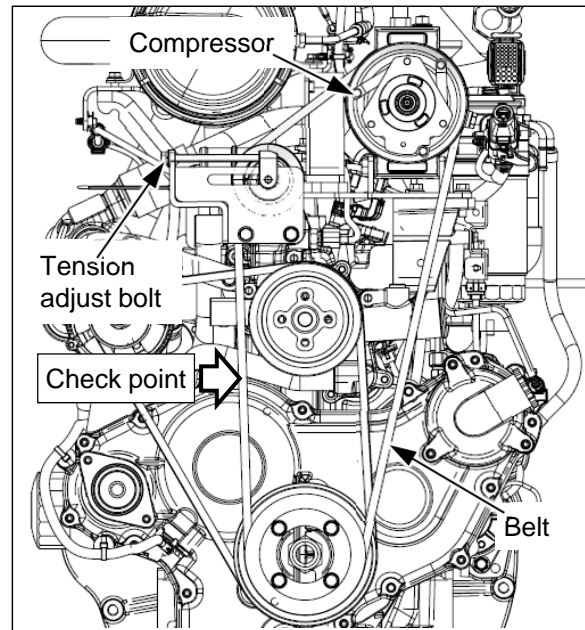

#### (5) Cleaning and replacing cabin air filters

- Check, clean and replace the cabin air filters periodically after referring to the chapter 5 in this manual.
- See chapter 5-7-(8), "Every 50 hour check" and See chapter 5-10-(4), "Every 500 hour check" in this manual.

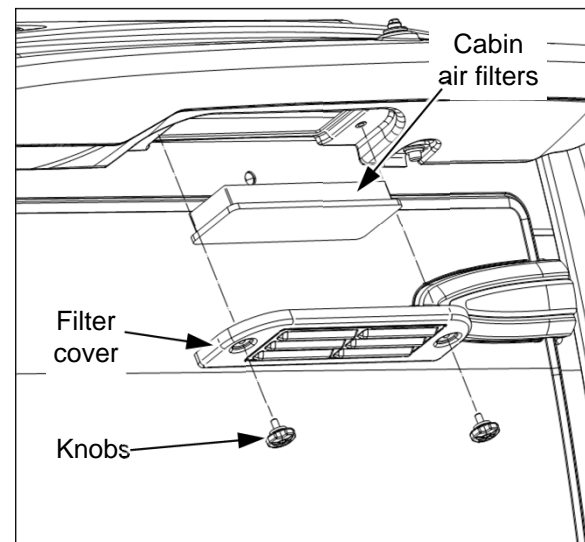



## 6-4. Every year check

### (1) Compressor check

- Check the oil leakage on the magnet clutch in front of the compressor.
- Check the abnormal noise sounds and if necessary, contact your authorized local dealer for check.

### (2) Control switch check

- Check the electric switches of the control panel is normally operated.

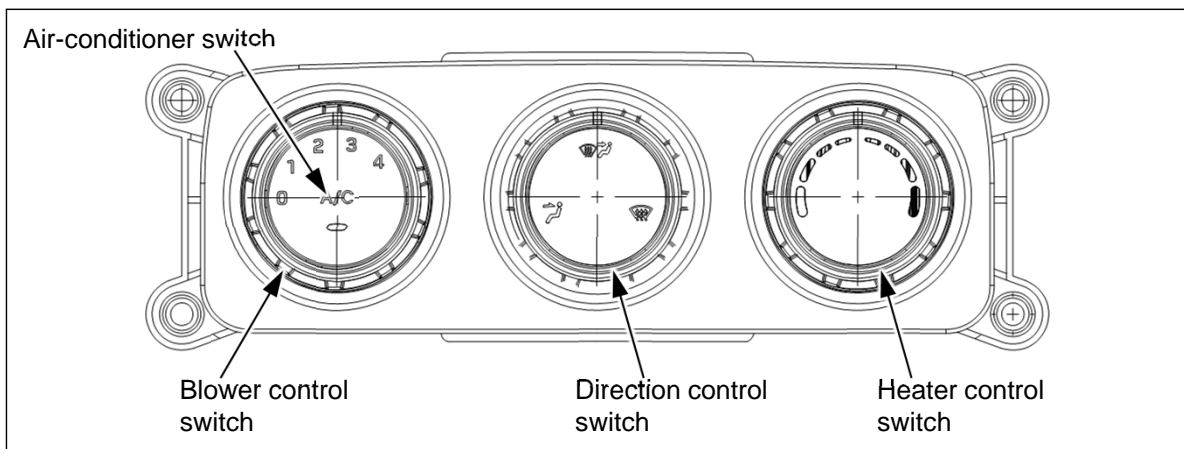



Caution

▶ If there is a trouble on the air conditioning system, DO NOT disassemble the components arbitrary, contact your authorized dealer for check.

## 6-5. Using Cut-off valve (if necessary)

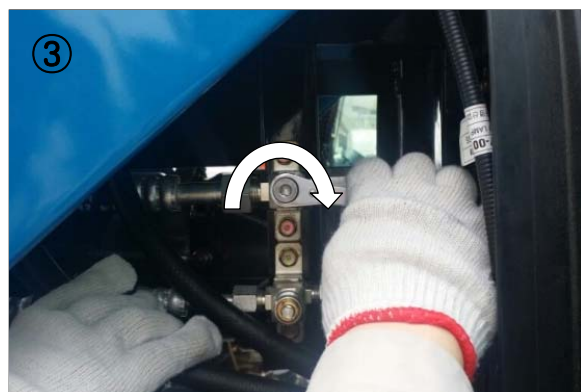
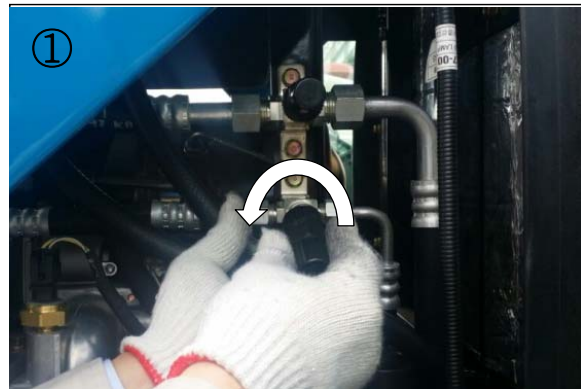
- When disassembling the air-conditioner hose line, comply with the following instruction;
  - ① Turn the plastic cap counter-clockwise and remove it.
  - ② Turn the high-pressure line valve (lower side) clockwise and tighten it.
  - ③ After starting engine and wait until for a about 30 seconds. Turn the low-pressure line valve (upper side) clockwise and tighten it.
  - ④ After stopping engine, remove the low-pressure line.
  - ⑤ Remove the high-pressure line.
- When assembling the air-conditioner hoses, comply with the reverse order of the disassembly procedure.



 <b>Caution</b>	<ul style="list-style-type: none"><li>▶ When disassembling the air-conditioner line, the refrigerant may splash into your body. Loosen the connection parts slowly.</li><li>▶ Plug the disassembled hoses with cap to protect them from pollutants.</li></ul>
--	---

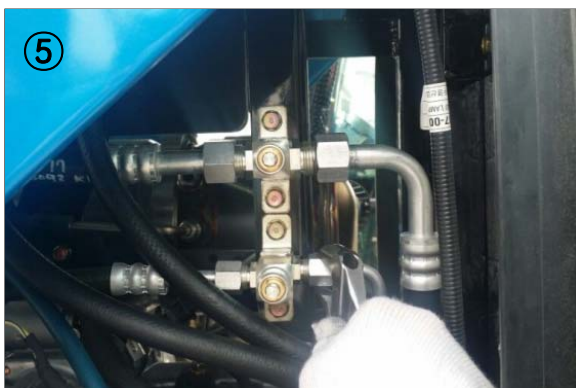

## 6-6. Troubleshooting

No.	Failures	Cause	Actions	
1	Fan motor does not turn.	Fuse blown.	Check and replace.	
		Wiring cut off and poor connection.	Repair the wiring or connect right.	
		Failure of fan motor.	Replace.	
		Resistor, relay and switch cut off.	Replace.	
2	Fan motor is normal but the air volume is small.	Evaporator or heater core was clogged.	Remove the obstacles and clean the cores.	
		Duct was misaligned.	Repair the duct.	
		Fan damaged or Fan motor failure.	Replace.	
		Filter was clogged.	Clean or replace.	
3	Air conditioning is insufficient despite of the normal operation of compressor and blower.	Low and high pressure is low.	Leakage of refrigerant.	Contact the dealer.
		Low and high pressure is high.	Refrigerant overcharged.	Contact the dealer.
			Condenser or radiator screen was clogged.	Clean condenser and the screen.
			Air is in air conditioning line.	Contact the dealer.
			Expansion valve does not control the refrigerant flow.	Contact the dealer.
		Low pressure is high, high pressure is low.	Compressor leakage.	Contact the dealer.
		Low pressure is vacuum intermittently.	Water is in air conditioning line.	Contact the dealer.
		Low pressure is vacuum, high pressure is low.	Receiver dryer, pipe or expansion valve is clogged.	Contact the dealer.

No.	Failures	Cause	Actions
4	The compressor does not turn or it is hard to revolve.	Belt loosened.	Adjust the belt tension.
		Temperature switch or pressure switch is "ON".	Check refrigerant amount.
		Coil of magnet clutch was shorted or cut off.	Contact the dealer.
		Compressor failure.	Contact the dealer.
		Wiring cut off or poor connection such as ground.	Check and repair.
5	The warm airflow does not blow.	The amount of warm water is small.	Check and add the engine coolant.
		Heater line is clogged or distorted.	Check and repair.
		Poor operation of the thermostat of engine coolant.	Repair or replace.

## 6-7. System diagram

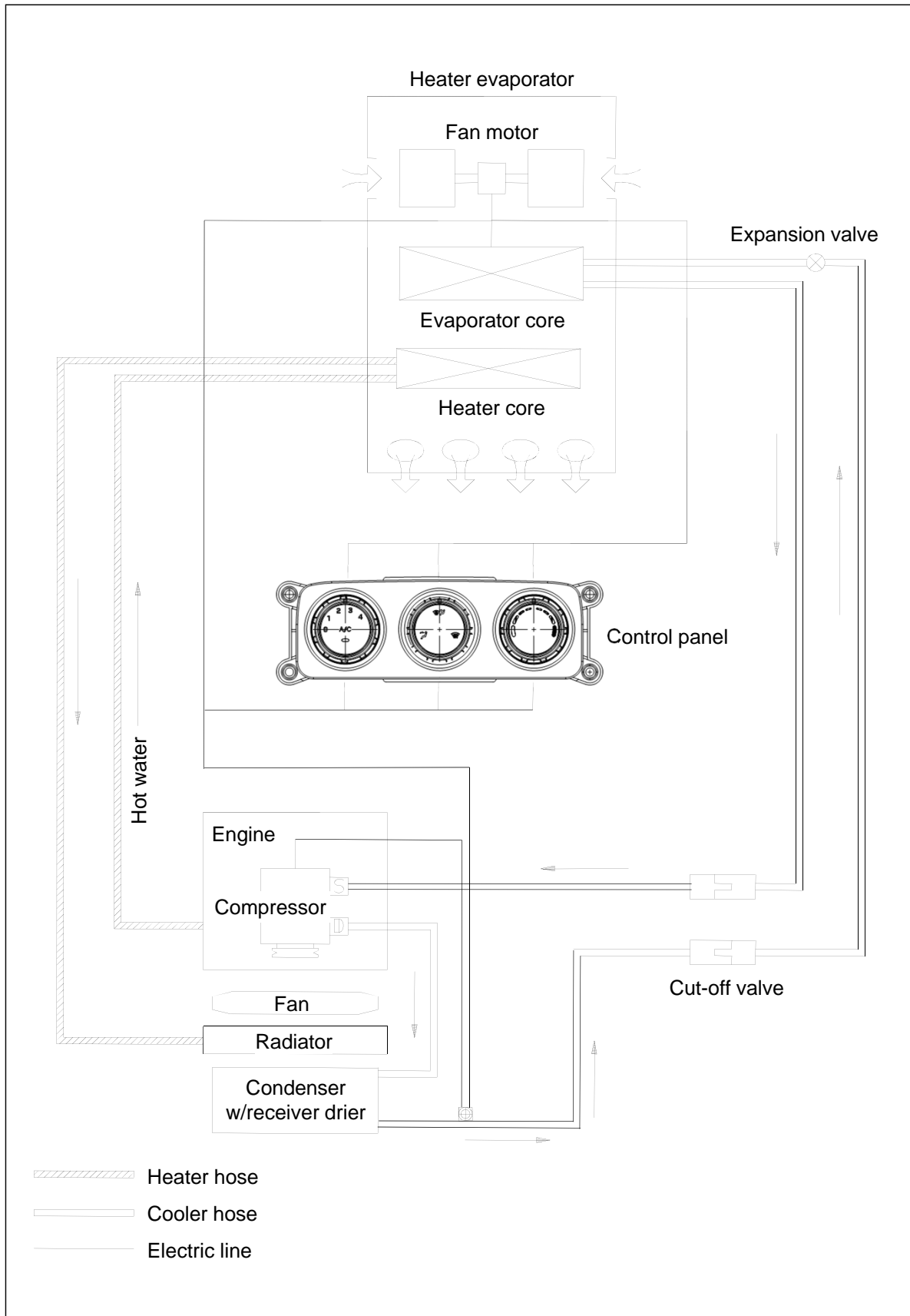



# 7. Dimension and Specification

## ① Cabin type

(Unit : mm)

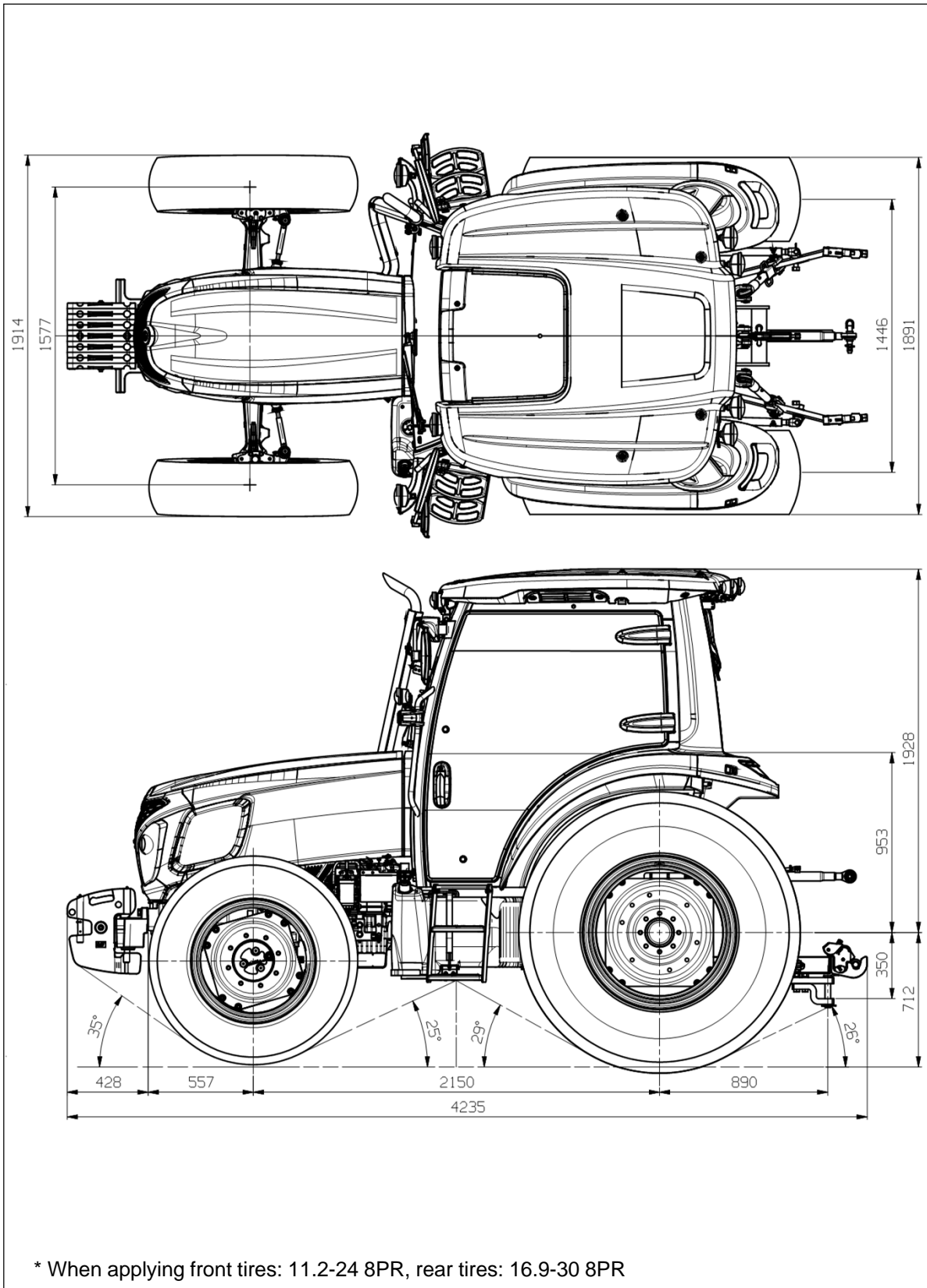

		<b>MT563</b>	<b>MT568</b>	<b>MT573</b>
<b>WEIGHT</b>	Frame Type	N/A	N/A	N/A
	Cabin Type	2913kg (6422 lb)	2913kg (6422 lb)	2997kg (6607 lb)
	Weight distribution	Front : Rear = 0.39 : 0.61		
	Bumper/Front weight	42kg (92.6 lb) / 40kg (88.2 lb) x 6EA (optional)		
<b>ENGINE</b>	Model	L4C25-T3A	L4C25-T2A	L4C25-T1A
	Type	In-line vertical, Water cooled 4-cycle diesel, CRDI		
	No. of cylinder	4		
	Diameter x stroke	88x103 (3.46x4.06 in)		
	Displacement	2505cc (152.86 in <sup>3</sup> )		
	Compression ratio	17:1		
	Engine speed	850 ~ 2700 rpm		
	Maximum torque	249N.m @1600rpm	249N.m @1600rpm	276N.m @1600rpm
	Rated power	47.0kW @2500rpm	50.7kW @2500rpm	54.4kW @2500rpm
<b>FUEL INJECTION SYSTEM</b>	Type	CRDI		
	Fuel filter	Replaceable cartridge type		
	Injection order	1-3-4-2		
<b>LUBRICATION SYSTEM</b>	Type	Forced circulation		
	Pump	Trochoid gear pump		
	Filter	Replaceable cartridge type		
<b>COOLING SYSTEM</b>	Pump	Centrifugal type		
	Temperature control	Thermostat		
	Air cleaner	Dry		
<b>TRANSMISSION</b>	Type	F12xR12 Mechanical transmission / F20xR20 w/Creeper (optional) F12xR12 Power shuttle / F20xR20 Power shuttle w/Creeper (optional)		
	Main clutch	Dry single clutch (Mechanical) / Wet clutch disks (Power shuttle)		
	Forward / Reverse	Synchro-shuttle type / Power shuttle (optional)		
	Differential lock	Electro-hydraulic differential lock (EHD)		



		<b>MT563</b>	<b>MT568</b>	<b>MT573</b>
PTO	Type	Independent rear PTO		
	No. of speed	3 speed gears (optional)		
	PTO / Engine	1st : 540 rpm / 2237 rpm 2nd : 750 rpm / 2471 rpm 3rd : 1000 rpm / 2318 rpm		
HYDRAULIC LIFT	3 Point linkage	CAT. 2		
	Draft load detection	Upper link sensing type		
	Lowering speed control and cylinder fixing device	Down speed control valve for MHL Built-in control valve for EHL		
	Pump	Gear type, Engine drive		
	Rated flow	50.0LPM (13.2GPM)		
	System pressure	19.0MPa (2756psi)		
	Lift capacity	Lower link end	3000 kg (6614 lb)	
24" behind lift point		2140 kg (4718 lb)		
REMOTE CONTROL	Type	Double acting / spring return or detent type (optional)		
	No. of Q/coupler	SAE ½", 6EA (optional : 4EA)		
	F/loader coupler	Front outlet valve / Joystick loader valve (optional)		
STEERING SYSTEM	Type	Hydrostatic		
	Oil	Transmission oil		
	Min. turning radius (with/without brake)	3427mm (10.8ft) / 3959mm (13.0ft)		
	Max. steering angle	50°		
	No. of steering turns	3.6 turns (lock to lock)		
	Rated oil flow	25.0LPM (6.6GPM)		
	System pressure	14.5MPa (2103psi)		

			<b>MT563</b>	<b>MT568</b>	<b>MT573</b>
ALTERNAT OR	Rated output	12V, 70A			
	Voltage control	Built-in (IC type)			
BATTERY	Voltage	12V			
	Capacity	100Ah			
START MOTOR	Output power	12V, 2.0kW			
	Operation	Solenoid			
LIGHTS	Headlights (Lower / Upper)	12V 55W / 60W			
	Turn signal lights / Side lights(front)	12V 16W / LED			
	Turn signal lights (rear)	12V 21W			
	Stop light / Taillight (rear)	12V LED / LED			
	Work light	12V 27W(Grille) / 37.5W(Cabin)			
	Instrument lights	LED			
	Indoor light	12V 10W (Cabin only)			
	Instrument indicator light	LED			
	Cold start aid	Glow plug			
STD.AGRI. TIRE	Front	9.5-24 (6PR)	9.5-24 (6PR)	11.2-24 (8PR)	
	Rear	14.9-30 (8PR)	14.9-30 (8PR)	16.9-30 (8PR)	
WHEEL TRACK ADJUSTMENT	Front	Tracks	7	7	5
		Dimension	1493~1803mm (58.8 ~ 71.0 in.)	1493~1803mm (58.8 ~ 71.0 in.)	1577~1777mm (62.1 ~ 70.0 in.)
	Rear	Tracks	5	5	5
		Dimension	1452~1736mm (57.2~ 68.3 in.)	1452~1736mm (57.2 ~ 68.3 in.)	1446~1846mm (56.9 ~ 72.7 in.)
** These specifications are only general product information about standard model. Actual data may vary depending on the various optional product, and also can be changed at any time to improve the product qualification without any prior notification **					

## Lubricants and Capacity

LUBRICANTS	CAPACITY	INTERNATIONAL STANDARD	RECOMMENDED ITEMS
Engine coolant	<b>10 ℓ</b> (2.6U.S.gals)	ASTM D6210	Soft water (50%)+ Anti-freeze (50%)
Fuel	<b>100 ℓ</b> (26.4U.S.gals)	- ASTM D975-08a Grade 2 - EN590 : 2009 Diesel fuel - BS2869 : 2006 Class A2	Ultra low sulfur diesel fuel, below 15 ppm
Engine oil	<b>7.0 ℓ</b> (1.8U.S.gals)	API CJ-4, ACEA E3	KIXX DL (Maker : GS Caltex)
Transmission oil (Hydraulic lift, Steering)	<b>55 ℓ</b> (14.5U.S.gals)	API-GL4 ISO VG 32/46	<b>LSTH400G</b> (Maker : GS Caltex)
Front axle oil	<b>4.4 L</b> (1.2 U.S.gals) for center housing <b>0.6 L</b> (0.2 U.S.gals) for each final housing <b>=5.6 L</b> (1.5 U.S.gals)	API-GL4 SAE 80W	EPK 80W90 (Maker : S-OIL TOTAL Co. Ltd.)
Grease (Front axle holder, 3-point linkage)	Proper amount	NLGI 2	MAHWAK Multi purpose or MAHWAK All purpose (Caltex)
Clutch & Brake oil	<b>0.5 ℓ</b> (0.1U.S.gals)	Mineral based oil (ISO 7308)	LSTH400 (S-OIL TOTAL) LHM PLUS (TOTAL) LHM (Mobil) LHM-S (Shell)

### RECOMMENDED ENGINE OIL VISCOSITIES

The correct engine oil viscosity grade is dependent upon ambient temperature. Refer to the below chart when selecting engine oil for your tractor.

In areas where prolonged periods of extreme temperatures are encountered, local lubricant practices are acceptable. Contact your authorized local dealer.

Ambient Temperature °C(°F)	-30 (-22)	-25 (-13)	-20 (-4)	-15 (5)	-10 (14)	-5 (23)	0 (32)	10 (50)	20 (68)	30 (86)	40 (104)
Oil Viscosity											





**LS Tractor USA LLC.**

PO Box 70, Battleboro, NC 27809

Tel : 252-984-0700

Fax : 252-984-0701

[www.lstractor.com](http://www.lstractor.com)

[www.lstractorusa.com](http://www.lstractorusa.com)

